

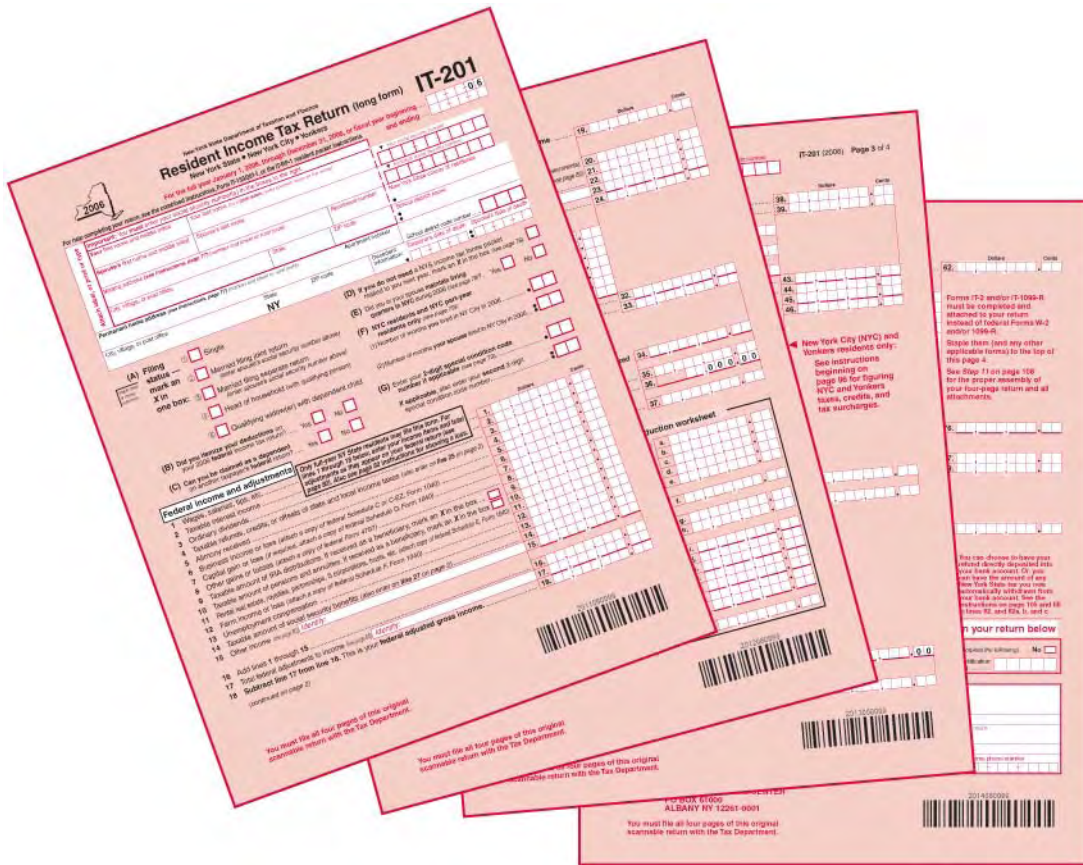

Instructions for Form IT-201

Full-Year Resident Income Tax Returns

New York State • New York City • Yonkers



Excerpt from Form IT-150/201-I
Web only version



Easy

All you need is a computer and Internet access!

Fast

Faster refunds than ever before! If you owe tax, several payment options are available. . . including File now/Pay later!

Safe

E-file is secure and accurate. You receive an electronic acknowledgment!

Free

You may qualify for FREE e-filing of your New York State income tax return! Check our Web site.

You can file your income tax return electronically (e-file) using your personal computer and one of the many commercially available software packages, or you can choose to have a tax professional e-file for you.

E-filing is the fastest way to receive your refund. The speed and accuracy of computers allow electronic returns to be processed faster than paper returns, and using tax preparation software greatly reduces the possibility of errors and delays. For more details, visit our e-filing Web site at: www.nystax.gov/elf

The following forms may be e-filed:

IT-150	IT-135	IT-217	IT-257
IT-201	IT-182	IT-219	IT-258
IT-201-ATT	IT-209	IT-220	IT-272
IT-203	IT-212	IT-230	IT-280
IT-203-ATT	IT-212-ATT	IT-240	IT-360.1
IT-203-B	IT-213	IT-241	IT-370
IT-203-C	IT-213-ATT	IT-249	IT-398
IT-112-C	IT-214	IT-250	IT-399
IT-112-R	IT-215	IT-255	IT-2105.9
IT-112.1	IT-216	IT-256	Y-203

E-file your tax-due return

E-filed returns with a balance due may be paid by submitting a check or money order with Form IT-201-V, *Payment Voucher for E-Filed Income Tax Returns*, by credit card (see Form IT-150, page 32, or Form IT-201, page 104), or by authorizing the Tax Department to withdraw the payment from your bank account (electronic funds withdrawal).

Table of Contents

For all full-year NYS resident filers:

What's new for 2006? 3
 Who must file/which form to file? 5
 Credits for individuals..... 6
 Credits for businesses..... 8
 Other forms you may have to file..... 9

For short Form IT-150 filers only:

Form IT-150 at a glance..... 12
 Steps 1 thru 11 for completing Form IT-150..... 15
 Checklist for Form IT-150..... 36

For all full-year NYS resident filers:

Additional information 38
 School districts and code numbers..... 42
 New York State Tax Table and Worksheets..... 46
 New York City Tax Table 56
 Sales and use tax information/worksheets..... 66

For long Form IT-201 filers only:

Form IT-201 at a glance..... 74
 Steps 1 thru 11 for completing Form IT-201 77
 Line instructions for Form IT-201-ATT 109
 Checklist for Form IT-201 113

For all full-year NYS resident filers:

Form IT-86, *Forms and Publications Ordering Information*
 Index inside back cover
 When to file / Important dates back cover
 Need help? back cover

What's new for 2006?

• Some tax rates reduced

Certain rates within the New York State and New York City tax rate schedules have been reduced. See pages 55 and 64.

• Standard deduction increased

Effective for tax years beginning on or after January 1, 2006, the standard deduction for *married filing joint return* and *qualifying widow(er)* increased from \$14,600 to \$15,000, and the standard deduction for *married filing separate return* increased from \$6,500 to \$7,500. See page 24 or 92.

• New York State organized militia subtraction modification expanded

The subtraction modification has been expanded to include income received as a member of the New York State Organized Militia for performing active service in the state pursuant to federal active Guard duty orders, for service other than training, issued under Title 10 of the United States Code. See page 22 or 88.

• Empire State film production credit extended

The Empire State film production credit has been extended to include calendar years 2006 through 2011. The cap on the aggregate amount of state tax credits has been increased from \$25 million to \$60 million for each calendar year. For additional information, see Form IT-248, *Claim for Empire State Film Production Credit*, and its instructions.

• New York City school tax credit increased

The NYC school tax credit increased from \$125 to \$230 for married individuals filing a joint return and qualifying widow(ers). The credit for single individuals, heads of household, or married individuals filing separate returns increased from \$62.50 to \$115. See page 30 or 101.

• Alternative fuels credit reinstated

The alternative fuels credit for investing in new alternative-fuel vehicle refueling property is reinstated for tax years beginning January 1, 2006, and ending December 31, 2010. For additional information, see Form IT-253, *Claim for Alternative Fuels Credit*, and its instructions.

• Brownfield tax credits definitions revised

The definition of *environmental zones* (EN-Zones) has been amended to include qualified sites that are the subject of a brownfield site cleanup agreement entered into prior to September 1, 2010.

The definition of *qualified tangible property* has been expanded to include a second set of criteria for purposes of the brownfield redevelopment tax credit. For additional information, see Form IT-611, *Claim for Brownfield Redevelopment Tax Credit*, and its instructions.

• Farmers' school tax credit amended

This credit has been amended to provide for enhancements effective for tax years beginning on or after January 1, 2006. For additional information, see Form IT-217, *Claim for Farmers' School Tax Credit*, and its instructions.

• New solar energy system equipment credit

For tax years beginning in and after 2006, a new credit is allowed, subject to certain limits, for expenditures incurred in 2006 and after for solar energy system equipment that utilizes solar radiation to provide heating, cooling, hot water, or electricity for use in an individual's principal residence. This new credit replaces the former solar electric generating equipment credit. For additional information, see Form IT-255, *Claim for Solar Energy System Equipment Credit*, and its instructions.

• New biofuel production credit

For tax years beginning in and after 2006, a new refundable credit is available for the production of biofuel at a biofuel plant located in New York State. For additional information, see Form IT-243, *Claim for Biofuel Production Credit*, and its instructions.

• New security officer training tax credit

A new credit is available for qualified building owners who employ qualified security officers. Taxpayers must file an application with the New York State Office of Homeland Security to receive an allocation of the credit. For more information, visit the New York State Office of Homeland Security Web site at www.security.state.ny.us and see Form IT-631, *Claim for Security Officer Training Tax Credit*.

• New noncustodial parent New York State earned income credit (EIC)

A new noncustodial parent New York State earned income credit may be available to a full-year resident individual who has attained the age of 18, is a parent of a minor child (or children) who do not reside with the individual, has an order requiring the individual to make child support payments that are payable through a support collection unit, and has paid an amount of child support due during the tax year for every order that requires the individual to make support payments. For additional information, see Form IT-209, *Claim for Noncustodial Parent New York State Earned Income Credit*, and its instructions.

• New home heating system credit

For tax years beginning in 2006 and 2007, a new credit is available for the costs incurred on or after July 1, 2006, and before July 1, 2007, that are directly associated with the replacement of an existing home heating system with a home heating system that qualifies for, and is labeled with, an Energy Star label. For additional information, see Form IT-240, *Claim for Home Heating System Credit*, its instructions, and TSB-M-06(4)C,(6)I.

• New clean heating fuel credit

For tax years beginning in 2006 and 2007, a New York State personal income tax credit is allowed for the purchase of bioheat that is used for space heating or hot water production for residential purposes within New York State. The credit applies to bioheat purchased on or after July 1, 2006, and before July 1, 2007. For additional information, see Form IT-241, *Claim for Clean Heating Fuel Credit*, its instructions, and TSB-M-06(4)C,(6)I.

• New Empire State child credit

For tax years beginning in and after 2006, a new refundable credit is available to full-year New York State residents. The credit is equal to 33% of the federal child tax credits (child tax credit and additional child tax credit) for each child who qualifies for the federal child tax credit and is at least four years old; or the sum of \$100 for each child who qualifies for the federal child tax credit and is at least four years old, whichever amount is greater. For additional information, see Form IT-213, *Claim for Empire State Child Credit*, and its instructions.

• New conservation easement tax credit

For tax years beginning in and after 2006, a new refundable credit is available for land that is subject to a conservation easement. For additional information, see Form IT-242, *Claim for Conservation Easement Tax Credit*, and its instructions.

• New handicapped-accessible taxicabs and livery service vehicles credit

A new credit is available effective January 1, 2006, through December 31, 2008, to companies that provide a taxicab service as defined in Vehicle and Traffic Law section 148-A or a livery service as defined in Vehicle and Traffic Law section 121-E. The credit is equal to the cost incurred for upgrading a vehicle so that it is handicapped accessible. The credit cannot exceed \$10,000 for each vehicle. This credit is not refundable; however, any credit amount not used in the current year may be carried forward to the following year. For additional information, see Form IT-239, *Claim for Handicapped-Accessible Taxicabs and Livery Service Vehicles Credit*, and its instructions.

How do I fill in the forms?

Please follow these guidelines.

Use black ink only (no red or other color ink or pencils) to print or type all entries.

Write your numbers and **X** marks like this:

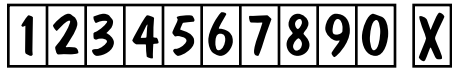

Carefully enter your money amounts so that the **dollar amount** ends in the box immediately to the **left** of the decimal point and the **cents amount** starts in the box immediately to the **right** of the decimal point.

Do not write in dollar signs, commas, or decimal points when making entries.

You can round money entries to the nearest dollar (fifty cents or more is rounded up). If you do round numbers, you must be consistent and round all numbers.

If you make an entry on a line, always fill in the cents area. If rounding or using a whole dollar amount, enter **00** in the cents boxes. Do not make any entry in areas that do not apply to you unless these instructions specifically direct you to do so; treat blank lines as zeros.

Mark an **X** to fill in boxes as appropriate. Do not use a check mark. Keep your Xs and numerals inside the boxes.

Example: If your total amount of *Wages, salaries, tips, etc.* for line 1 is \$37,114.48, your money field entry on line 1 should look like this:

... 1. [] [] , [3] [7] [1] [1] [4] . [4] [8]

If you are **rounding all money items** on your return to the nearest dollar, it should look like this:

... 1. [] [] , [3] [7] [1] [1] [4] . [0] [0]

How do I use the instructions?

To help you decide whether you have to file a New York State return, and which of the two New York resident returns you should file, use the flow chart on page 5. Taxpayers who previously filed Form IT-201 may now be eligible to file Form IT-150.

Once you know which form to file, review the at-a-glance illustration for that form (on page 12 or page 74) that shows the form broken down into completion steps. Use the color-coded tabs to help you find specific instructions for any portion of the return.

Keep an eye out for the following icons or symbols. They will alert you to important new information, to areas where particular caution should be used, and to filing shortcuts.



New information



Caution



Time-saving tip

Finally, please use the checklist on page 36 or page 113 to avoid mistakes that might slow the processing of your return, and delay any refund you may be entitled to.

Common words and phrases

To save space and enhance clarity, these instructions may use common abbreviations, including:

EIC =	earned income credit
federal AGI =	federal adjusted gross income
IRC =	Internal Revenue Code
IRS =	Internal Revenue Service
New York AGI =	New York State adjusted gross income
NYS =	New York State
NYC =	New York City

New York State full-year residents: Who must file/which form to file?

How to use this chart

Each box in the chart below contains a question that can be answered **Yes** or **No**.

Start in the upper-left corner and answer the question in that box. Then follow the arrow that matches your answer

to the next box. Answer each question that the arrows lead you to, until you reach a box that either tells you to file a New York return (on Form IT-150 or on Form IT-201), or tells you that you do not have to file a New York return.

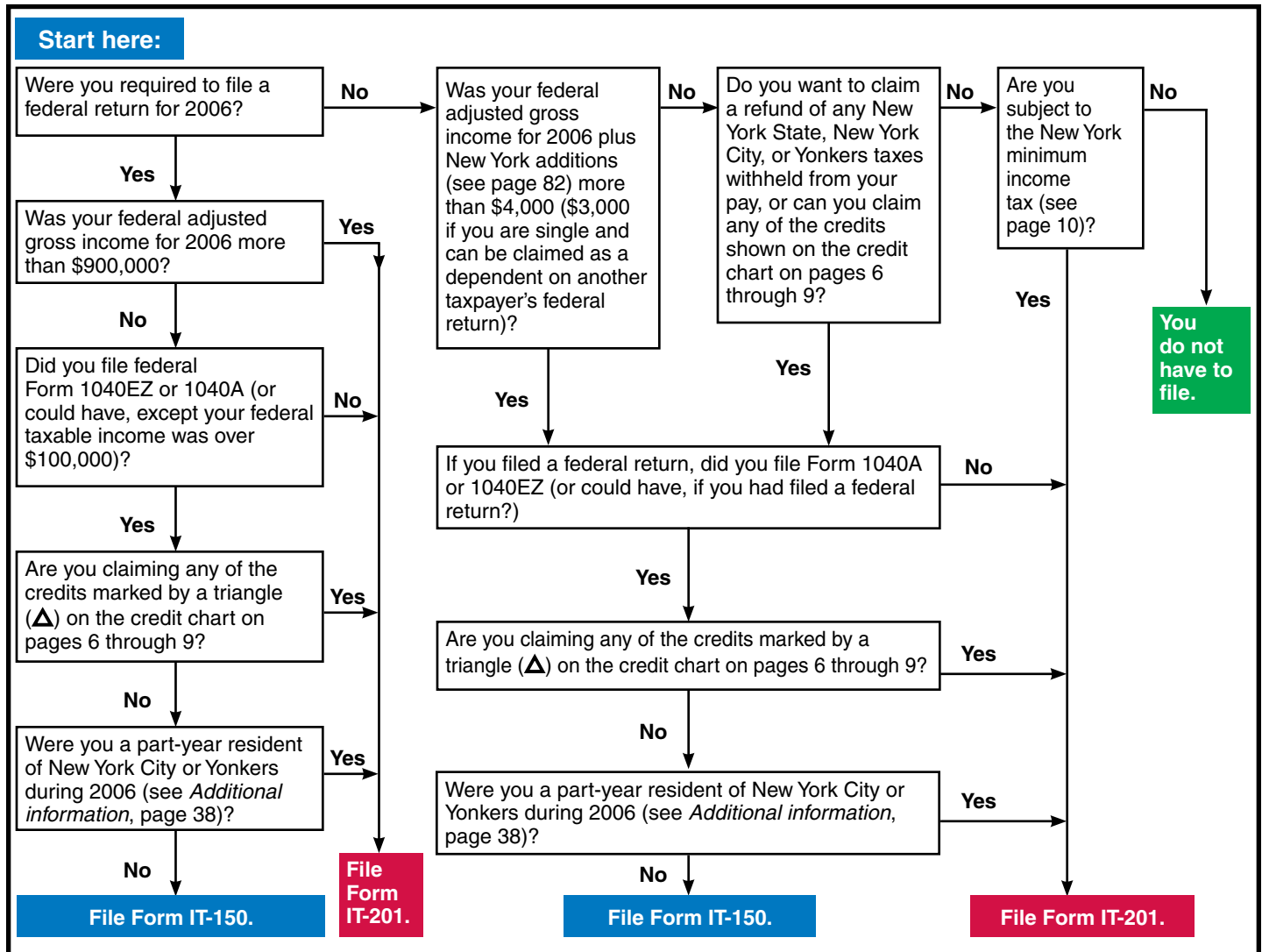

Additional notes to all filers:

- Do you have to **attach other forms**? If you need to pay other taxes, see **Other forms you may have to file** on pages 9 and 10.
- To claim tax credits, see the credit charts on pages 6 through 9.
- Does your child have **investment income** over \$1,700? It would be to your advantage to file a New York return for your child to report your child's investment income, since there will be no New York tax on the first \$3,000 of that income. When you file your federal return, report your child's investment income on federal Form 8615 (instead of federal Form 8814). If you file Form 8814, the amount of your child's investment income over \$1,700 that was included in your federal gross income will be reported on your New York return and taxed at your rate.

New York nonresidents and part-year residents:

If you were a nonresident or a part-year resident of New York State and you received income from New York sources in 2006, you must file Form IT-203, *Nonresident and Part-Year Resident Income Tax Return*.

Separate returns are required for some married taxpayers who file a joint federal return. If one of you was a New York State resident and the other was a nonresident or part-year resident, you must each file a separate New York return. The resident must use Form IT-150 or Form IT-201. The nonresident or part-year resident, if required to file a New York State return, must use Form IT-203. However, if you both choose to file a joint New York State return, use Form IT-150 or IT-201.

Credits for individuals

Credit	See Key below.	You may qualify for this credit if you:	Form
Accumulation distribution	△	are a beneficiary of a trust who received an accumulation distribution.	page 109*
Accumulation distribution (New York City)	△	are a beneficiary of a trust who received an accumulation distribution during the period you were a New York City resident.	page 110*
Alternative fuels	△	have unused credit for purchasing a new alternative-fuel vehicle or converting a vehicle to use alternative fuel, or have unused credit or a new credit for investing in new clean-fuel vehicle refueling property.	IT-253
Child and dependent care	□	are able to claim the federal child and dependent care credit.	IT-216
Claim of right (New York State)	△ □	had a claim of right credit on your federal return for income that was subject to New York State tax on a prior year's return.	IT-257
Claim of right (New York City)	△ □	had a claim of right credit on your federal return for income that was subject to New York City tax on a prior year's return.	IT-257
Claim of right (Yonkers)	△ □	had a claim of right credit on your federal return for income that was subject to Yonkers tax on a prior year's return.	IT-257
NEW Clean heating fuel	△ □	purchased bioheat that is used for space heating or hot water production for residential purposes.	IT-241
College tuition	□	are a full-year New York State resident paying college tuition expenses.	IT-272
NEW Conservation easement	△ □	own land that is subject to a conservation easement held by a public or private conservation agency.	IT-242
Defibrillator	△	purchased an automated external defibrillator machine.	IT-250
Earned income (New York State)	□	are allowed an earned income credit (EIC) on your federal income tax return or (new for 2006) are a noncustodial parent and have paid child support through a support collection unit.	IT-215 or IT-209
Earned income (New York City)	□	are a New York City resident allowed an EIC on your federal income tax return.	IT-215
NEW Empire State child	□	claimed the federal child tax credit or you have a qualifying child.	IT-213
Fuel cell electric generating equipment	△	purchased fuel cell electric generating equipment and installed it in New York State.	IT-259
Green building	△	had expenses for a building meeting certain environmental and energy standards.	DTF-630
Historic barn rehabilitation	△	paid or incurred expenses to restore a historic barn in New York State.	IT-212-ATT
NEW Home heating system	△ □	replaced an existing home heating system with an Energy Star labeled heating system.	IT-240
Household (New York State)		cannot be claimed as a dependent on another taxpayer's federal return and your federal Adjusted Gross Income (AGI) is not over \$32,000 (\$28,000 if filing as single).	page 25* or 95*
Household (New York City)		cannot be claimed as a dependent on another taxpayer's federal return and your federal AGI is not over \$22,500 (\$12,500 if filing as single).	page 26* or 97*

(continued on page 7)

Key: △ You may **not** apply for this credit using short Form IT-150; **you must use Form IT-201**.
 □ This credit may be refunded to you, even if you owe no tax.
 ○ You may apply for this credit even if you don't have to file a tax return.

* See this page in the instructions. There is no form for this credit.

Credits for individuals (continued)

Credit	See Key below.	You may qualify for this credit if you:	Form
Long-term care insurance	△	paid premiums during the tax year for a long-term care insurance policy.	IT-249
Lump-sum distribution	△	received a federal lump-sum distribution while a New York State resident that was taxed by a specified jurisdiction outside New York State.	IT-112.1
Nursing home assessment	△ □	paid an amount directly relating to the assessment imposed on a residential health care facility.	IT-258
Real property tax	○ □	are a full-year New York State resident paying real property taxes or rent.	IT-214
Residential fuel oil storage tank	△	have unused credit for replacing or installing a residential fuel oil storage tank.	page 112*
School tax (New York City)	○ □	are a full- or part-year New York City resident and you cannot be claimed as a dependent on another taxpayer's federal return. You do not have to file Form NYC-210 if you are claiming this credit on Form IT-150 or IT-201.	NYC-210
NEW Solar energy system equipment	△	purchased solar energy system equipment and installed it at your principal residence.	IT-255
Solar and wind energy	△	have unused credit for purchasing and installing a solar or wind energy system.	page 112*
Taxes paid to another state or jurisdiction	△	received income while a New York State resident from outside New York State that was taxed by a jurisdiction outside New York State.	IT-112-R
Taxes paid to Canada	△	received income while a New York State resident from Canada that was taxed by a province of Canada.	IT-112-C

Key: △ You may **not** apply for this credit using short Form IT-150; **you must use Form IT-201**.
 □ This credit may be refunded to you, even if you owe no tax.
 ○ You may apply for this credit even if you don't have to file a tax return.

* See this page in the instructions. There is no form for this credit.



For up-to-the-minute information on New York State tax matters, including matters that may affect your New York State personal income tax return, visit our Web site at

www.nystax.gov

Credits for businesses

Credit	See Key below.	You may qualify for this credit if you or your business:	Form
Alternative fuels	△	have unused credit for purchasing a new alternative-fuel vehicle or converting a vehicle to use alternative fuel, or have unused credit or a new credit for investing in new clean-fuel vehicle refueling property.	IT-253
NEW Biofuel production	△ □	produced biofuel at a biofuel plant located in New York State.	IT-243
Brownfield credits	△ □	was issued a certificate of completion by the New York State Department of Environmental Conservation (DEC) under the Brownfield Cleanup Program.	IT-611 IT-612 IT-613
NEW Clean heating fuel	△ □	purchased bioheat that is used for space heating or hot water production for residential purposes.	IT-241
NEW Conservation easement	△ □	own land that is subject to a conservation easement held by a public or private conservation agency.	IT-242
Defibrillator	△	purchased an automated external defibrillator machine.	IT-250
Empire State film production	△ □	had expenses for the production of certain qualified film and television shows.	IT-248
Empire zone (EZ) capital	△	made investments or contributions to an EZ business or project, or have an unused EZ capital tax credit from a prior year.	IT-602
EZ employment incentive	△ □	acquired, built, or erected property for which an EZ investment credit is allowed.	IT-603
EZ investment	△ □	is EZ-certified and placed qualified property in service in an EZ.	IT-603
EZ wage	△ □	is EZ-certified and paid wages to employees within the EZ.	IT-601
Employment incentive	△	put property in service that qualified for the investment credit.	IT-212-ATT
Employment of persons with disabilities	△	employed persons with disabilities.	IT-251
Farmers' school tax	△ □	is in the farming business and paid school taxes on agricultural property in New York State.	IT-217
Financial services industry EZ employment incentive	△ □	is a financial services industry (FSI) business that was allowed an FSI EZ investment credit.	IT-605
Financial services industry EZ investment	△ □	is an FSI business that placed qualified property in service in an EZ.	IT-605
Financial services industry employment incentive	△ □	put property in service that qualified for the FSI investment tax credit.	IT-252-ATT
Financial services industry investment	△ □	is an FSI business that placed qualified property in service in New York State.	IT-252
Fuel cell electric generating equipment	△	purchased fuel cell electric generating equipment and installed it in New York State.	IT-259
Green building	△	had expenses for a building that meets certain environmental and energy standards.	DTF-630
NEW Handicapped-accessible taxicabs and livery service vehicles	△	upgraded a vehicle so that it is handicapped accessible.	IT-239
Historic barn rehabilitation	△	paid or incurred expenses to restore a historic barn in New York State.	IT-212-ATT

(continued on page 9)

Key: △ You may **not** apply for this credit using short Form IT-150; **you must use Form IT-201.**
 □ This credit may be refunded to you, even if you owe no tax.

Credits for businesses *(continued)*

Credit	See Key below.	You may qualify for this credit if you or your business:	Form
IMB energy tax	<input type="checkbox"/>	is an industrial or manufacturing business (IMB) that paid taxes on energy in NYS.	DTF-623
Investment	<input type="checkbox"/>	placed qualified property in service in New York State.	IT-212
Long-term care insurance	<input type="checkbox"/>	paid premiums during the tax year for a long-term care insurance policy.	IT-249
Low-income housing	<input type="checkbox"/>	had construction or rehabilitation expenses for eligible rent-restricted housing.	DTF-624
QETC capital	<input type="checkbox"/>	held investments in a qualified emerging technology company (QETC).	DTF-622
QETC employment	<input type="checkbox"/>	is a qualified emerging technology company that paid wages to full-time employees.	DTF-621
QETC facilities, operations, and training	<input type="checkbox"/>	is a QETC that is an eligible taxpayer with qualified research and development property, research expenses, or high-technology training expenses.	DTF-619
QEZE real property taxes	<input type="checkbox"/>	is a qualified empire zone enterprise (QEZE) that paid eligible real property taxes.	IT-606
QEZE tax reduction	<input type="checkbox"/>	is a QEZE that meets the employment requirements.	IT-604
NEW Security officer training	<input type="checkbox"/>	employed qualified security officers and received a certificate from the New York State Office of Homeland Security.	IT-631
Special additional mortgage recording tax	<input type="checkbox"/>	paid the special additional mortgage recording tax.	IT-256
Unincorporated business tax (UBT New York City)	<input type="checkbox"/>	is a New York City business that filed Form NYC-202 and paid UBT; or was a partner in a New York City partnership that filed Form NYC-204 and paid UBT.	IT-219
Zone equivalent area (ZEA) wage	<input type="checkbox"/>	has an unused credit from a prior year for wages paid to employees within a ZEA.	IT-601.1

Key: **▲** You may **not** apply for this credit using short Form IT-150; **you must use Form IT-201.**
 This credit may be refunded to you, even if you owe no tax.

Other forms you may have to file**Form****Purpose**
**Form IT-2, Summary of
Federal Form W-2 Statements**

You must complete Form(s) IT-2 if you received **any** federal Form(s) W-2. You must complete Form(s) IT-2 even if your federal Form(s) W-2 do not show any New York State, New York City, or Yonkers wages or tax withheld. In addition, if you received foreign income but did not receive a federal Form W-2, you must complete Form IT-2. Attach Form(s) IT-2 to your New York return. Do not attach any federal Form(s) W-2 to your return; keep them for your records.

Married taxpayers filing jointly can report W-2 records for both spouses on one Form IT-2, but must mark an **X** in the box to indicate which spouse the information is for.

**Form IT-1099-R, Summary of
Federal Form 1099-R Statements**

You must complete Form(s) IT-1099-R if you **received any** federal Form(s) 1099-R that show any New York State, New York City, or Yonkers **tax withheld**. Attach Form(s) IT-1099-R to your New York return. Do not attach any federal Form(s) 1099-R to your return; keep them for your records. (To avoid confusion, please note that the New York form has an **IT** prefix in the form number.)

Married taxpayers filing jointly can report 1099-R records for both spouses on one Form IT-1099-R, but must mark an **X** in the box to indicate which spouse the information is for.

(continued on page 10)

Other forms you may have to file *(continued)***Form IT-220, *Minimum Income Tax***

To report New York State tax preference items totaling more than your specific deduction of \$5,000 (\$2,500 if you are married and filing separately). For New York purposes, the federal preference items subject to New York minimum income tax are: (1) depreciation (pre-1987) (ACRS depreciation on recovery property placed in service in New York in 1985 and 1986, ACRS depreciation on all IRC section 280F recovery property placed in service prior to January 1, 1987); (2) intangible drilling costs; and (3) qualified small business stock (excluded under section 1202). Also include the amount of New York addition for restoration of net operating loss deduction. You may have to file Form IT-220 even if you are not required to file Federal Form 6251, *Alternative Minimum Tax - Individuals*. For more information, see the instructions for Form IT-220.

Form IT-221, *Disability Income Exclusion*

To compute the amount of your disability income that may be excluded from income on Form IT-201. For more information, see the instructions for Form IT-221.

Form IT-230, *Separate Tax on Lump-Sum Distributions*

To compute tax due if you used federal Form 4972 to compute your federal tax on a lump-sum distribution from a qualified retirement plan. For more information, see the instructions for Form IT-230.

Form IT-360.1, *Change of City Resident Status*

To compute the tax due if you changed your New York City or Yonkers resident status during the year. You must pay the New York City income tax or Yonkers resident income tax surcharge for the part of the year that you lived in New York City or Yonkers. For more information, see the instructions for Form IT-360.1.

Form IT-398, *New York State Depreciation Schedule for IRC Section 168(k) Property*

To compute your New York depreciation deduction for IRC section 168(k) property placed in service beginning on or after June 1, 2003 (except for resurgence zone property and New York liberty zone property described in IRC section 1400L(b)(2)). For more information, see the instructions for Form IT-398.

Form IT-399, *New York State Depreciation Schedule*

To compute your New York depreciation deduction for property placed in service during tax years beginning in 1981, 1982, 1983, and 1984.

For property placed in service outside New York State for tax years beginning after December 31, 1984, but before January 1, 1994, see addition A-15 for Form IT-201 on page 84. For more information, see the instructions for Form IT-399.

Form IT-2105, *Estimated Income Tax Payment Voucher for Individuals*

To pay estimated tax for 2007 if you expect to owe at least \$300 of New York State or New York City or Yonkers income tax after deducting tax withheld and credits you are entitled to claim. For more information, see the instructions for Form IT-2105 and Publication 94, *Should You Be Paying Estimated Tax in 2007?*

Form Y-203, *Yonkers Nonresident Earnings Tax Return*

To compute the tax due if you were **not** a Yonkers resident for 2006 but you earned wages or had self-employment income from within Yonkers, and you have to file a New York State income tax return. For more information, see the instructions for Form Y-203.

Form IT-201-X, *Amended Resident Income Tax Return*

To amend a previously filed New York State income tax return. Generally, an amended return claiming credit for, or a refund of, an overpayment must be filed within three years of the date that the original return was filed, or within two years of the date that the tax was paid, whichever is later. However, if you file an amended federal return, you must also file an amended New York State return within 90 days from the date you amend your federal return.

You must also file an amended return to correct any error on your original state return and to report changes made on your federal return by the IRS. You must report such changes to the New York State Tax Department within 90 days from the date the IRS makes its final determination. For more information, see the instructions for Form IT-201-X.

Electronic services

We invite you to visit our Web site at www.nystax.gov to learn about our growing list of electronic services.



- Learn how to e-file your income tax return.
- Determine if you are eligible for **free** e-filing with **FreeFile**.
- Determine which income tax form to file.
- Pay your income taxes by credit card or electronic funds withdrawal.
- Apply for an automatic extension of time to file your return.
- Check the status of your income tax refund.
- Review your estimated tax account balance.
- Visit our Taxpayer Answer Center to find answers to all your tax questions.
- View and pay open assessments.
- Use the penalty and interest calculator.
- Sign up for free e-mail notifications through our subscription service.

www.nystax.gov

Additional information

The information on pages 38 through 72 is for use in completing either the short Form IT-150 or the long Form IT-201.

Definitions used to determine resident, nonresident, or part-year resident

You may have to pay income tax as a New York State resident even if you are not considered a resident for other purposes. For income tax purposes, your resident status depends on where you were domiciled and where you maintained a permanent place of abode during the taxable year.

Domicile

In general, your *domicile* is the place you intend to have as your permanent home. Your domicile is, in effect, where your permanent home is located. It is the place you intend to return to after being away (as on vacation abroad, business assignment, educational leave, or military assignment).

You can have only one domicile. Your New York domicile does not change until you can demonstrate that you have abandoned your New York domicile and established a new permanent domicile outside New York State.

A change of domicile must be *clear and convincing*. Easily controlled factors such as where you vote, where your driver's license and registration are issued, or where your will is located are **not** primary factors in establishing domicile. To determine whether you have, in fact, changed your domicile, you should compare (1) the size, value, and nature of use of your first residence to the size, value, and nature of use of your newly acquired residence; (2) your employment and/or business connections in both locations; (3) the amount of time spent in both locations; (4) the physical location of items that have significant sentimental value to you in both locations; and (5) your close family ties in both locations. A change of domicile is *clear and convincing* only when your primary ties are clearly **greater** in the new location. When weighing your primary ties, keep in mind that some may weigh more heavily than others, depending upon your overall lifestyle. If required by the Tax Department, it is the taxpayer's responsibility to produce documentation showing the necessary intention to effect a change of domicile.

If you move to a new location but intend to stay there only for a limited amount of time (no matter how long), your domicile does not change. For example, Mr. Green of ABC Electronics in Newburgh, New York, was temporarily assigned to the Atlanta, Georgia branch office for two years. After his stay in Atlanta, he returned to his job in New York. His domicile did not change during his stay in Georgia; it remained New York State.

If your domicile is in New York State and you go to a foreign country because of a business assignment by your employer, or for study, research or any other purpose, your domicile does not change unless you show that you definitely do not intend to return to New York.

Permanent place of abode

A *permanent place of abode* is a residence (a building or structure where a person can live) that you permanently maintain, whether you own it or not, and usually includes a residence your husband or wife owns or leases. A place of abode is not permanent if you maintain it only during a temporary or limited period of time for a particular purpose.

Resident

You are a New York State resident for income tax purposes if:

a) Your domicile is not New York State but you maintain a permanent place of abode in New York State for more than 11 months of the year and spend **184 days or more** (a part of a day is a day for this purpose) in New York State during the taxable year.

However, if you are a member of the armed forces, and your domicile is not New York State, you are not a resident under this definition; or

b) Your domicile is New York State. However, even if your domicile is New York, you are not a resident if you meet **all three** of the conditions in either Group A or Group B as follows:

Group A

- 1) You did not maintain any permanent place of abode in New York State during the taxable year; and
- 2) You maintained a permanent place of abode outside New York State during the entire taxable year; and
- 3) You spent **30 days or less** (a part of a day is a day for this purpose) in New York State during the taxable year.

Group B

- 1) You were in a foreign country for at least 450 days during any period of 548 consecutive days; and
- 2) You spent **90 days or less** (a part of a day is a day for this purpose) in New York State during this 548-day period, and your spouse (unless legally separated) or minor children spent **90 days or less** (a part of a day is a day for this purpose) in New York during this 548-day period in a permanent place of abode maintained by you; and
- 3) During the nonresident portion of the taxable year in which the 548-day period begins, and during the nonresident portion of the taxable year in which the 548-day period ends, you were present in New York State for no more than the number of days which bears the same ratio to 90 as the number of days in such portion of the taxable year bears to 548. The following formula illustrates this condition:

$$\frac{\text{Number of days in the nonresident portion}}{548} \times 90 = \text{Maximum number of days allowed in New York State}$$

Nonresident

You are a New York State nonresident if you were not a resident of New York State for any part of the year.

Part-year resident

You are a New York State part-year resident if you meet the definition of resident or nonresident for only part of the year.

New York City and Yonkers

For the definition of a **New York City** or **Yonkers** resident, nonresident, and part-year resident, see the definitions of a New York State resident, nonresident, and part-year resident above, and substitute *New York City* or *Yonkers* in place of *New York State*.

For more information on nonresidents and part-year residents, see the instructions for Form IT-203.

Additional information (continued)

Special accruals

As a full-year New York State resident for 2006, or if you are a full-year New York City resident or New York City part-year resident for 2006, you may have to use special accrual rules (see below) to compute your New York State and New York City personal income tax for 2006.

If you are subject to the special accrual rules, you must file Form IT-201. You cannot file Form IT-150. In addition, you will need to obtain Publication 210, *Change of Resident Status Special Accruals (For tax year 2006)*, to assist you in computing your 2006 tax (see *Need help?* on the back cover).

Full-year New York State residents —

You are subject to the special accrual rules **only** if you have accrued income for 2006 (see below), **and**

- you were a nonresident of New York State on December 31, 2005; or
- you will be a New York State nonresident on January 1, 2007.

You have accrued income for 2006 if:

- you have an item of non-New York source income* that was fixed and determinable in a tax year prior to 2006, but you are reporting that income for federal income tax purposes in tax year 2006; or
- you have an item of income that was fixed and determinable in tax year 2006, but you will be reporting that income for federal income tax purposes in a tax year after 2006.

Full-year and part-year New York City residents —

You are subject to the special accrual rules **only** if you have accrued income for 2006 (see below), **and**

- you were a nonresident of New York City on December 31, 2005, but you were a full-year New York City resident for tax year 2006; or
- you were a full-year New York City resident for 2006 but you will be a New York City nonresident on January 1, 2007; or
- you were a New York City part-year resident for tax year 2006.

You have accrued income for 2006 if:

- you have an item of non-New York source income* that was fixed and determinable in a tax year prior to 2006, but you are reporting that income for federal income tax purposes in tax year 2006; or
- you have an item of income that was fixed and determinable in tax year 2006, but you will be reporting that income for federal income tax purposes in a tax year after 2006; or
- you have an item of income that was fixed and determinable in your 2006 New York City resident period, but that income is not reportable for federal income tax purposes in your 2006 New York City resident period; or
- you have an item of non-New York source income* that was fixed and determinable in your 2006 New York City nonresident period, but that income is not reportable for federal income tax purposes in your 2006 New York City nonresident period.

Special instructions for Form IT-150, line 30

Line 30 New York City resident tax

If one spouse was a resident of New York City for all of 2006 and the other a nonresident for all of 2006, compute on a separate sheet of paper the NYC resident tax on the New York State taxable income of the city resident as if you had filed separate federal returns reduced by the NYC household credit (if applicable). Transfer the amount from your separate sheet to line 30. Be sure to write the name and social security number of the city resident and **Taxable income of New York City resident** on that paper and attach it to your return.

Special instructions for Form IT-150, line 33

Line 33 Yonkers resident income tax surcharge

If one spouse was a resident of Yonkers for all of 2006 and the other a nonresident for all of 2006, compute on a separate sheet of paper the Yonkers resident income tax surcharge on the New York State tax of the Yonkers resident as if you had filed separate federal returns. Transfer the amount from your separate sheet to line 33. Be sure to write the name and social security number of the Yonkers resident and **Yonkers resident income tax surcharge** on that paper and attach it to your return.

Estates and trusts

Estates and trusts are subject to the New York State personal income tax. The fiduciary for an estate or trust must file Form IT-205, *Fiduciary Income Tax Return*. Each beneficiary of an estate or trust must include his or her share of the estate or trust income on Form IT-201. For more information on responsibilities of beneficiaries, see *Beneficiaries (estates and trusts)* on page 81.

Deceased taxpayers

If a taxpayer died after 2005 and before filing a return for 2006, the taxpayer's spouse or personal representative may have to file and **sign** a return for that taxpayer. A personal representative can be an executor, administrator or anyone who is in charge of the deceased taxpayer's property. If a taxpayer did not have to file a federal return but had New York State tax withheld, a New York return must be filed to get a refund. If a joint federal income tax return was filed for the deceased taxpayer and the surviving spouse, a joint New York State return can be filed on Form IT-150 or Form IT-201, depending on which federal form was filed. Write **Filing as surviving spouse** in the area where you sign the return. If someone else is the personal representative for the deceased spouse, he or she must also sign the return. The filing due date is the same as if the deceased taxpayer had lived. The person who files the return for the deceased taxpayer should write the deceased taxpayer's date of death in the area indicated near the top of the return.

(continued)

* Non-New York source income is income that is **not** attributable to (1) a business, trade, profession, or occupation carried on in **New York State**, or (2) the ownership of any interest in real or tangible personal property in **New York State**.

Additional information (continued)

Partnerships/limited liability partnerships or companies

Partnerships, limited liability partnerships (LLPs) and limited liability companies (LLCs), limited liability investment companies (LLICs) and limited liability trust companies (LLTCs) that are treated as partnerships for federal purposes are not subject to the New York State personal income tax, but individual members of the partnerships are.

If your partnership has a partner who is a New York State resident, or if the partnership has any income from New York State sources, it must file Form IT-204, *Partnership Return*. If your partnership carried on a business in New York City, it may also have to file Form NYC-204, *City of New York Unincorporated Business Tax Partnership Return*. Since New York State does not administer the New York City unincorporated business tax, do not file your NYC-204 with your state return.

Innocent spouse relief

There are three forms of innocent spouse relief: innocent spouse, separation of liability, and equitable relief. You may qualify for relief from full or partial tax liability on a joint return as an *innocent spouse* if: (1) there is an understatement of tax on a joint return because of an omission or error involving income, deduction, credit, or basis; (2) you can show that when you signed the return you did not know and had no reason to know of the understatement; and (3) taking into account all the facts and circumstances, it would be unfair to hold you liable for the understated tax. You may also request a *separation of liability* for any understated tax on a joint return if you and your spouse or former spouse are no longer married, or are legally separated, or have lived apart at all times during the 12-month period prior to the date of filing for relief. If you do not qualify as an innocent spouse or for separation of liability, you may qualify for *equitable relief* if you can show that, taking into account all the facts and circumstances, you should not be held liable for any understatement or underpayment of tax. For more information, see Form IT-285, *Request for Innocent Spouse Relief (and Separation of Liability and Equitable Relief)*. You may use Form IT-285 only for innocent spouse relief under the three circumstances stated above. Do **not** file Form IT-285 with your return.

If you want to disclaim your spouse's defaulted guaranteed student, state university, or city university loan or past-due support or past-due legally enforceable debt owed to a New York State agency or a New York City tax warrant judgment debt because you do not want to apply your part of a joint refund or refundable credit to a debt owed solely by your spouse, use Form IT-280, *Nonobligated Spouse Allocation*. You must complete Form IT-280 and attach it to the back of your original return when filed. (Also see *Disclaiming of spouse's debt* on page 31 (Form IT-150) or page 103 (Form IT-201)).

Members of the armed forces

If you are a member of the military and a New York State resident, the amount of your military pay that is subject to federal income tax is also subject to New York income tax.

For more information, see Publication 361, *New York State Income Tax Information for Military Personnel and Veterans*.

Keep a copy of your tax records

Please remember to keep a copy of your completed income tax return. Also keep copies of any books, records, schedules, statements, or other related documents.

The Tax Department may ask you to provide copies of these records after you have filed your income tax returns.

You should retain copies of your return for at least seven years after you file your return.

Amending your return

File Form IT-201-X to amend a previously filed New York State income tax return. See *Other forms you may have to file* on page 10.

Paid preparer information

For information relating to the signing of returns by a paid preparer (anyone you pay to prepare your return), e-file mandate for paid preparers, and other requirements relating to paid preparers, see Publication 58, *Information for Income Tax Return Preparers*.

Additional information (continued)

How to get New York City forms

If you need to get tax forms and instructions from the NYC Department of Finance:

Online - Visit www.nyc.gov/finance

By fax - Call Finance's *Tax Fax Service* at **(212) 504-4038** from the phone connected to your fax machine or modem (24 hours a day, 7 days a week).

By mail - Call Finance's *Forms Ordering Service* at **(212) 504-4035** anytime to receive forms and instructions by mail.

For information on NYC business taxes, call *Finance Customer Assistance* at **(212) 504-4036**. For information on NYC property taxes call **(212) 504-4080**. Customer assistance is available weekdays from 8:00 a.m. to 5:00 p.m.

Statute of limitations

Generally, you must file a claim for a credit or refund of an overpayment of income tax within the later of three years from the time you filed the return or two years from the time you paid the tax. If you did not file a return, you must file the claim for a credit or refund within two years from the time you paid the tax.

Privacy notification

The Commissioner of Taxation and Finance may collect and maintain personal information pursuant to the New York State Tax Law, including but not limited to, sections 5-a, 171, 171-a, 287, 308, 429, 475, 505, 697, 1096, 1142, and 1415 of that Law; and may require disclosure of social security numbers pursuant to 42 USC 405(c)(2)(C)(i).

This information will be used to determine and administer tax liabilities and, when authorized by law, for certain tax offset and exchange of tax information programs as well as for any other lawful purpose.

Information concerning quarterly wages paid to employees is provided to certain state agencies for purposes of fraud prevention, support enforcement, evaluation of the effectiveness of certain employment and training programs and other purposes authorized by law.

Failure to provide the required information may subject you to civil or criminal penalties, or both, under the Tax Law.

This information is maintained by the Director of Records Management and Data Entry, NYS Tax Department, W A Harriman Campus, Albany NY 12227; telephone 1 800 225-5829. From areas outside the United States and outside Canada, call (518) 485-6800.

Private delivery services

If you choose, you may use a private delivery service, instead of the U.S. Postal Service, to mail in your return and tax payment. However, if, at a later date, you need to establish the date you filed your return or paid your tax, you cannot use the date recorded by a private delivery service unless you used a delivery service that has been designated by the U.S. Secretary of the Treasury or the Commissioner of Taxation and Finance. (Currently designated delivery services are listed in Publication 55, Designated Private Delivery Services. See *Need help?* on the back cover for information on obtaining forms and publications.) If you have used a designated private delivery service and need to establish the date you filed your return, contact that private delivery service for instructions on how to obtain written proof of the date your return was given to the delivery service for delivery. If you use any private delivery service, whether it is a designated service or not, send the forms covered by these instructions to: State Processing Center, 101 Enterprise Drive, Kingston NY 12401.

Albany – Erie

School districts and code numbers

Use this list to find the name and code number of the public school district located in the county where you were a resident on December 31, 2006. (If you are a New York City resident, look for your individual county listing.) Enter the school district name and code number at the top of the front of your return in the white spaces and

boxes provided. If you do not know the name of your school district, contact your nearest public school.



You must enter your school district and code number even if you were absent temporarily, if the school your children attended was not in your school district, or if you had no children attending school. School aid may be affected if your school district or code number is not correct.

County

Albany

Albany 005
 Berne-Knox-Westerlo 050
 Bethlehem 051
 Cairo-Durham 076
 Cohoes 122
 Duaneburg 153
 Green Island 236
 Greenville 240
 Guilderland 246
 Maplewood-Colonie 371
 Menands 388
 Middleburgh 393
 Mohonasen 402
 Niskayuna 439
 North Colonie 443
 Ravena-Coeymans-Selkirk 524
 Schalmont 568
 Schoharie 572
 South Colonie 595
 Voorheesville 660
 Watervliet 674

Allegany

Alfred-Almond 010
 Andover 017
 Arkport 021
 Belfast 044
 Bolivar-Richburg 054
 Canaseraga 083
 Canisteo-Greenwood 086
 Cuba-Rushford 138
 Dalton-Nunda (Keshequa) 320
 Fillmore 192
 Friendship 209
 Genesee Valley 018
 Hinsdale 277
 Letchworth 339
 Pioneer 498
 Portville 512
 Scio 575
 Wellsville 683
 Whitesville 702

Bronx

Bronx 068

Brooklyn (see Kings)

Broome

Afton 003
 Bainbridge-Guilford 031
 Binghamton 053
 Chenango Forks 107
 Chenango Valley 108
 Cincinnatus 113
 Deposit 146
 Greene 238
 Harpursville 259
 Johnson City 313
 Maine-Endwell 364
 Marathon 372
 Newark Valley 432
 South Mountain-Hickory 720
 Susquehanna Valley 627
 Union-Endicott 651
 Vestal 658
 Whitney Point 703
 Windsor 710

Cattaraugus

Allegany-Limestone 011
 Cattaraugus-Little Valley 094
 Cuba-Rushford 138
 Ellicottville 181
 Forestville 198
 Franklinville 205
 Frewsburg 208
 Gowanda 230
 Hinsdale 277
 Olean 462
 Pine Valley 497
 Pioneer 498
 Portville 512
 Randolph 522
 Salamanca 556
 Springville-Griffith Institute 244
 Ten Broeck Academy and Franklinville 205
 West Valley 690

Cayuga

Auburn 025
 Cato-Meridian 092
 Groton 245
 Hannibal 257
 Homer 281
 Jordan-Elbridge 315
 Moravia 407
 Oswego 472
 Port Byron 507
 Red Creek 525
 Skaneateles 588
 Southern Cayuga 609
 Union Springs 650
 Weedsport 681

Chautauqua

Bemus Point 048
 Brocton 067
 Cassadaga Valley 091
 Chautauqua Lake 104
 Clymer 119
 Dunkirk 155
 Falconer 189
 Forestville 198
 Fredonia 206
 Frewsburg 208
 Gowanda 230
 Jamestown 306
 Panama 479
 Pine Valley 497
 Randolph 522
 Ripley 536
 Sherman 583
 Silver Creek 587
 Southwestern 611
 Westfield Academy and Central 692

Chemung

Corning-Painted Post 132
 Elmira 182
 Elmira Heights 183
 Horseheads 287
 Newfield 436
 Odessa-Montour 460
 Spencer-Van Etten 613
 Watkins Glen 675
 Waverly 676

Chenango

Afton 003
 Bainbridge-Guilford 031
 Brookfield 070
 Chenango Forks 107
 Cincinnatus 113
 DeRuyter 141
 Gilbertsville-Mount Upton 222
 Greene 238
 Harpursville 259
 Norwich 455
 Otselic Valley 606
 Oxford Academy and Central 475
 Sherburne-Earlville 582
 Sidney 586
 Unadilla Valley 422
 Whitney Point 703

Clinton

AuSable Valley 026
 Beekmantown 043
 Chateaugay 102
 Chazy 105
 Northeastern Clinton 418
 Northern Adirondack 453
 Peru 492
 Plattsburgh 503
 Saranac 560
 Saranac Lake 561

Columbia

Chatham 103
 East Greenbush 158
 Germantown 221
 Hudson 289
 Ihabod Crane 294
 New Lebanon 426
 Pine Plains 496
 Red Hook 526
 Schodack 571
 Taconic Hills 632
 Webutuck (Northeast) 680

Cortland

Cincinnatus 113
 Cortland 134
 DeRuyter 141
 Dryden 152
 Fabius-Pompey 187
 Greene 238
 Groton 245
 Homer 281
 Marathon 372
 McGraw 385
 Newark Valley 432
 Tully 646
 Whitney Point 703

Delaware

Andes 016
 Bainbridge-Guilford 031
 Charlotte Valley 101
 Delhi 144
 Deposit 146
 Downsville 150
 Franklin 203
 Gilboa-Conesville 223
 Hancock 256

Delaware (continued)

Jefferson 310
 Livingston Manor 349
 Margaretville 375
 Oneonta 464
 Roscoe 545
 Roxbury 547
 Sidney 586
 South Kortright 601
 Stamford 620
 Sullivan West 143
 Unatego 649
 Walton 663
 Worcester 711

Dutchess

Arlington 022
 Beacon 040
 Carmel 089
 Dover 149
 Haldane 249
 Hyde Park 293
 Millbrook 396
 Pawling 483
 Pine Plains 496
 Poughkeepsie 514
 Red Hook 526
 Rhinebeck 531
 Spackenkil 612
 Taconic Hills 632
 Wappingers 665
 Webutuck (Northeast) 680

Erie

Akron 004
 Alden 007
 Amherst 719
 Attica 024
 Buffalo 073
 Cheektowaga 106
 Cheektowaga-Sloan 589
 Clarence 114
 Cleveland Hill 115
 Depew 145
 East Aurora 156
 Eden 171
 Frontier 210
 Gowanda 230
 Grand Island 232
 Hamburg 251
 Holland 278
 Iroquois 300
 Kenmore-
 Town of Tonawanda 319
 Lackawanna 326
 Lake Shore (Evans-Brant) 330
 Lancaster 332
 Maryvale 378
 North Collins 442
 Orchard Park 468
 Pioneer 498
 Silver Creek 587
 Springville-Griffith Institute 244
 Sweet Home 628
 Tonawanda City 638
 West Seneca 689
 Williamsville 706

School districts and code numbers

Essex – Nassau

Essex

AuSable Valley 026
Crown Point 137
Elizabethtown-Lewis 179
Keene 317
Lake Placid 328
Minerva 399
Moriah 408
Newcomb 434
Putnam 517
Saranac Lake 561
Schroon Lake 573
Ticonderoga 636
Westport 696
Willsboro 707

Franklin

AuSable Valley 026
Brasher Falls 058
Brushton-Moira 072
Chateaugay 102
Malone 365
Northern Adirondack 453
Salmon River 558
Saranac Lake 561
St. Regis Falls 619
Tupper Lake 647

Fulton

Amsterdam 015
Broadalbin-Perth 065
Dolgeville 148
Edinburg 173
Fonda-Fultonville 197
Fort Plain 201
Galway 212
Gloversville 227
Johnstown 314
Mayfield 383
Northville 454
Oppenheim-Ephratah 467
Saint Johnsville 618
Wheelerville 698

Genesee

Akron 004
Albion 006
Alden 007
Alexander 008
Attica 024
Batavia 036
Brockport 066
Byron-Bergen 075
Caledonia-Mumford 077
Elba 177
Iroquois 300
Le Roy 338
Medina 387
Oakfield-Alabama 458
Pavilion 482
Pembroke 487
Royalton-Hartland 548
Wyoming 714

Greene

Cairo-Durham 076
Catskill 093
Coxsackie-Athens 135
Gilboa-Conesville 223
Greenville 240
Hunter-Tannersville 291
Margaretville 375
Onteora 466
Ravena-Coeymans-Selkirk 524
Windham-Ashland-Jewett 709

Hamilton

Indian Lake 296
Inlet 298
Lake Pleasant 329
Long Lake 354
Northville 454
Piseco 499
Poland 506
Raquette Lake 523
Wells 682

Herkimer

Adirondack 002
Cherry Valley-Springfield 616
Dolgeville 148
Fort Plain 201
Frankfort-Schuyler 202
Herkimer 268
Holland Patent 279
Ilion 295
Little Falls 346
Mohawk 401
Mount Markham 412
New Hartford 424
Oppenheim-Ephratah 467
Owen D. Young
(Van Hornesville) 474
Poland 506
Remsen 528
Richfield Springs 533
Sauquoit Valley 564
Saint Johnsville 618
Town of Webb 639
West Canada Valley 685
Whitesboro 701

Jefferson

Alexandria 009
Belleville-Henderson 045
Carthage 090
Copenhagen 129
General Brown 217
Gouverneur 229
Hammond 253
Indian River 297
LaFargeville 324
Lyme 356
Sackets Harbor 288
Sandy Creek 559
South Jefferson 600
Thousand Islands 634
Watertown 672

Kings (Brooklyn)

Brooklyn 071

Lewis

Adirondack 002
Beaver River 041
Camden 079
Carthage 090
Copenhagen 129
Harrisville 261
Lowville Academy and
Central 355
Sandy Creek 559
South Jefferson 600
South Lewis 602

Livingston

Avon 029
Caledonia-Mumford 077
Canaseraga 083
Dalton-Nunda (Keshequa) 320

Livingston (continued)

Dansville 140
Geneseo 218
Honeoye 282
Honeoye Falls-Lima 283
Le Roy 338
Livonia 350
Mount Morris 413
Naples 420
Pavilion 482
Perry 490
Wayland-Cohocton 677
Wheatland-Chili 697
York 716

Madison

Brookfield 070
Canastota 084
Cazenovia 095
Chittenango 111
DeRuyter 141
East Syracuse-Minoa 167
Edmeston 174
Fabius-Pompey 187
Fayetteville-Manlius 370
Hamilton 252
Madison 361
Morrisville-Eaton 411
Mount Markham 412
Oneida 463
Otselic Valley 606
Sherburne-Earlville 582
Stockbridge Valley 624
Unadilla Valley 422
Vernon-Verona-Sherrill 584
Waterville 673

Manhattan (see New York)

Monroe

Avon 029
Brighton 063
Brockport 066
Byron-Bergen 075
Caledonia-Mumford 077
Churchville-Chili 112
East Irondequoit 160
East Rochester 165
Fairport 188
Gates Chili 216
Greece 235
Hilton 276
Holley 280
Honeoye Falls-Lima 283
Kendall 318
Penfield 488
Pittsford 500
Rochester 538
Rush-Henrietta 549
Spencerport 614
Victor 659
Wayne 678
Webster 679
West Irondequoit 299
Wheatland-Chili 697

Montgomery

Amsterdam 015
Broadalbin-Perth 065
Canajoharie 081
Cherry Valley-Springfield 616
Cobleskill-Richmondville 120
Duanesburg 153

Montgomery (continued)

Fonda-Fultonville 197
Fort Plain 201
Galway 212
Johnstown 314
Owen D. Young
(Van Hornesville) 474
Saint Johnsville 618
Schalmont 568
Schoharie 572
Scotia-Glenville 576
Sharon Springs 579

Nassau

Amityville 014
Baldwin 032
Bellmore 046
Bellmore-Merrick CHS*
Bethpage 052
Carle Place 088
Cold Spring Harbor 123
East Meadow 162
East Rockaway 166
East Williston 168
Elmont 184
Farmingdale 191
Floral Park-Bellerose 195
Franklin Square 204
Freeport 207
Garden City 214
Glen Cove 224
Great Neck 234
Hempstead 265
Herricks 270
Hewlett-Woodmere 272
Hicksville 273
Island Park 302
Island Trees 303
Jericho 311
Lawrence 337
Levittown 340
Locust Valley 352
Long Beach 353
Lynbrook 357
Malverne 366
Manhasset 368
Massapequa 379
Merrick 389
Mineola 398
New Hyde Park-
Garden City Park 425
North Bellmore 441
North Merrick 444
North Shore 448
Oceanside 459
Oyster Bay-East Norwich 476
Plainedge 501
Plainview-Old Bethpage 502
Port Washington 511
Rockville Centre 539
Roosevelt 544
Roslyn 546
Seaford 577
Sewanhaka CHS*
Syosset 630
Uniondale 652
Valley Stream CHS*
Valley Stream 13 655
Valley Stream 24 656
Valley Stream 30 657
Wantagh 664
Westbury 691
West Hempstead 687

(continued)

* Do not use a high school district (CHS) in Bellmore-Merrick, Sewanhaka, or Valley Stream. Use the code number for the elementary school district where you live.

New York – Staten Island

School districts and code numbers

New York (Manhattan)

Manhattan **369**

New York City (see individual counties)

Niagara

Akron **004**
 Barker **035**
 Lewiston-Porter **341**
 Lockport **351**
 Medina **387**
 Newfane **435**
 Niagara Falls **437**
 Niagara Wheatfield **438**
 North Tonawanda **450**
 Royalton-Hartland **548**
 Starpoint **621**
 Wilson **708**

Oneida

Adirondack **002**
 Brookfield **070**
 Camden **079**
 Central Square **098**
 Clinton **117**
 Holland Patent **279**
 Madison **361**
 Mount Markham **412**
 New Hartford **424**
 New York Mills **430**
 Oneida **463**
 Oriskany **469**
 Poland **506**
 Remsen **528**
 Rome **541**
 Sauquoit Valley **564**
 Stockbridge Valley **624**
 Town of Webb **639**
 Utica **653**
 Vernon-Verona-Sherrill **584**
 Waterville **673**
 West Canada Valley **685**
 Westmoreland **695**
 Whitesboro **701**

Onondaga

Baldwinsville **033**
 Cato-Meridian **092**
 Cazenovia **095**
 Central Square **098**
 Chittenango **111**
 DeRuyter **141**
 East Syracuse-Minoa **167**
 Fabius-Pompey **187**
 Fayetteville-Manlius **370**
 Homer **281**
 Jamesville-Dewitt **307**
 Jordan-Elbridge **315**
 LaFayette **325**
 Liverpool **348**
 Lyncourt **358**
 Marcellus **373**
 Moravia **407**
 North Syracuse **449**
 Onondaga **465**
 Phoenix **494**
 Skaneateles **588**
 Solvay **593**
 Syracuse **631**
 Tully **646**
 West Genesee **686**
 Westhill **694**

Ontario

Bloomfield **157**
 Canandaigua **082**
 Geneva **219**
 Honeoye **282**
 Honeoye Falls-Lima **283**
 Livonia **350**
 Lyons **360**
 Manchester-Shortsville
 (Red Jacket) **527**
 Marcus Whitman **374**
 Naples **420**
 Newark **431**
 Palmyra-Macedon **478**
 Penn Yan **489**
 Phelps-Clifton Springs
 (Midlakes) **493**
 Pittsford **500**
 Victor **659**
 Wayland-Cohocton **677**

Orange

Chester **110**
 Cornwall **133**
 Eldred **178**
 Florida **196**
 Goshen **228**
 Greenwood Lake **243**
 Highland Falls-
 Fort Montgomery **275**
 Kiryas Joel Village **725**
 Marlboro **377**
 Middletown **394**
 Minisink Valley **400**
 Monroe-Woodbury **403**
 Newburgh **433**
 North Rockland **445**
 Pine Bush **495**
 Port Jervis **510**
 Ramapo **626**
 Tuxedo **648**
 Valley **405**
 Walkkill **662**
 Warwick Valley **668**
 Washingtonville **669**

Orleans

Albion **006**
 Barker **035**
 Brockport **066**
 Byron-Bergen **075**
 Holley **280**
 Kendall **318**
 Lyndonville **359**
 Medina **387**
 Oakfield-Alabama **458**
 Royalton-Hartland **548**

Oswego

Altmar-Parish-Williamstown **012**
 Camden **079**
 Cato-Meridian **092**
 Central Square **098**
 Fulton **211**
 Hannibal **257**
 Mexico Academy and
 Central **390**
 Oswego **472**
 Phoenix **494**
 Pulaski Academy and
 Central **516**
 Sandy Creek **559**
 South Jefferson **600**

Otsego

Bainbridge-Guilford **031**
 Charlotte Valley **101**
 Cherry Valley-Springfield **616**
 Cobleskill-Richmondville **120**
 Cooperstown **128**
 Edmeston **174**
 Franklin **203**
 Gilbertsville-Mount Upton **222**
 Laurens **336**
 Milford **395**
 Morris **409**
 Mount Markham **412**
 Oneonta **464**
 Owen D. Young
 (Van Hornesville) **474**
 Richfield Springs **533**
 Schenevus
 (Andrew S. Draper) **570**
 Sharon Springs **579**
 Sidney **586**
 Unadilla Valley **422**
 Unatego **649**
 Worcester **711**

Putnam

Brewster **060**
 Carmel **089**
 Garrison **215**
 Haldane **249**
 Lakeland **331**
 Mahopac **363**
 North Salem **447**
 Pawling **483**
 Putnam Valley **518**
 Wappingers **665**

Queens

Queens **519**

Rensselaer

Averill Park **027**
 Berlin **049**
 Brunswick (Brittonkill) **064**
 Cambridge **078**
 East Greenbush **158**
 Hoosick Falls **285**
 Hoosic Valley **284**
 Ichabod Crane **294**
 Lansingburgh **334**
 Mechanicville **386**
 New Lebanon **426**
 North Greenbush (Williams) **704**
 Rensselaer **530**
 Schodack **571**
 Stillwater **623**
 Troy **642**
 Wynantskill **713**

Richmond (Staten Island)

Staten Island **622**

Rockland

Clarkstown **423**
 East Ramapo **615**
 Nanuet **419**
 North Rockland **445**
 Nyack **457**
 Pearl River **484**
 Ramapo **626**
 South Orangetown **605**

Saratoga

Amsterdam **015**
 Ballston Spa **034**
 Broadalbin-Perth **065**
 Burnt Hills-Ballston Lake **074**
 Corinth **131**
 Edinburg **173**
 Galway **212**
 Hadley-Luzerne **247**
 Hudson Falls **290**
 Mechanicville **386**
 Niskayuna **439**
 Northville **454**
 Saratoga Springs **562**
 Schuylerville **574**
 Scotia-Glenville **576**
 Shenendehowa **581**
 South Glens Falls **597**
 Stillwater **623**
 Waterford-Halfmoon **670**

Schenectady

Amsterdam **015**
 Burnt Hills-Ballston Lake **074**
 Duaneburg **153**
 Galway **212**
 Mohonasen **402**
 Niskayuna **439**
 Schalmont **568**
 Schenectady **569**
 Schoharie **572**
 Scotia-Glenville **576**
 South Colonie **595**

Schoharie

Berne-Knox-Westerlo **050**
 Cairo-Durham **076**
 Canajoharie **081**
 Charlotte Valley **101**
 Cobleskill-Richmondville **120**
 Duaneburg **153**
 Fonda-Fultonville **197**
 Gilboa-Conesville **223**
 Greenville **240**
 Jefferson **310**
 Middleburgh **393**
 Schoharie **572**
 Sharon Springs **579**
 Stamford **620**

Schuylers

Bradford **057**
 Corning-Painted Post **132**
 Dundee **154**
 Hammondsport **254**
 Horseheads **287**
 Odessa-Montour **460**
 South Seneca **607**
 Spencer-Van Etten **613**
 Trumansburg **643**
 Watkins Glen **675**

Seneca

Clyde-Savannah **118**
 Geneva **219**
 Lyons **360**
 Phelps-Clifton Springs
 (Midlakes) **493**
 Romulus **542**
 Seneca Falls **578**
 South Seneca **607**
 Trumansburg **643**
 Waterloo **671**

Staten Island (see Richmond)

School districts and code numbers

Steuben – Yates

Steuben

Addison 001
 Alfred-Almond 010
 Andover 017
 Arkport 021
 Avoca 028
 Bath 037
 Bradford 057
 Campbell-Savona 080
 Canaseraga 083
 Canisteo-Greenwood 086
 Corning-Painted Post 132
 Dansville 140
 Elmira 182
 Hammondsport 254
 Hornell 286
 Jasper-Troupsburg 308
 Naples 420
 Penn Yan 489
 Prattsburg 515
 Wayland-Cohocton 677
 Whitesville 702

St. Lawrence

Alexandria 009
 Brasher Falls 058
 Brushton-Moira 072
 Canton 087
 Clifton-Fine 116
 Colton-Pierrepont 124
 Edwards-Knox 724
 Gouverneur 229
 Hammond 253
 Harrisville 261
 Hermon-DeKalb 269
 Heuvelton 271
 Indian River 297
 Lisbon 345
 Madrid-Waddington 362
 Massena 380
 Morristown 410
 Norwood-Norfolk 456
 Ogdensburg 461
 Parishville-Hopkinton 480
 Potsdam 513
 Salmon River 558
 St. Regis Falls 619
 Tupper Lake 647

Suffolk

Amagansett 013
 Amityville 014
 Babylon 030
 Bayport-Blue Point 039
 Bay Shore 038
 Brentwood 059
 Bridgehampton 062
 Center Moriches 096
 Central Islip 097
 Cold Spring Harbor 123
 Commack 125
 Comsewogue 126
 Connetquot 127
 Copiague 130
 Deer Park 142
 East Hampton 159
 East Islip 161
 East Moriches 163
 Eastport/South Manor 170
 East Quogue 164
 Elwood 186
 Farmingdale 191
 Fire Island 193
 Fishers Island 194
 Greenport 239
 Half Hollow Hills 250
 Hampton Bays 255

Suffolk (continued)

Harborfields 258
 Hauppauge 264
 Huntington 292
 Islip 304
 Kings Park 321
 Lindenhurst 344
 Longwood 392
 Mattituck-Cutchogue 382
 Middle Country 391
 Miller Place 397
 Montauk 404
 Mount Sinai 414
 New Suffolk 429
 North Babylon 440
 Northport-East Northport 452
 Oysterponds 477
 Patchogue-Medford 481
 Port Jefferson 509
 Quogue 521
 Remsenburg-Speonk 529
 Riverhead 537
 Rocky Point 540
 Sachem 553
 Sagaponack 555
 Sag Harbor 554
 Sayville 566
 Shelter Island 580
 Shoreham-Wading River 585
 Smithtown 590
 Southampton 608
 South Country 596
 South Huntington 599
 Southold 610
 Springs 617
 Three Village 635
 Tuckahoe Common 645
 Wainscott 661
 West Babylon 684
 Westhampton Beach 693
 West Islip 688
 William Floyd 381
 Wyandanch 712

Sullivan

Eldred 178
 Ellenville 180
 Fallsburg 190
 Liberty 342
 Livingston Manor 349
 Minisink Valley 400
 Monticello 406
 Pine Bush 495
 Port Jervis 510
 Sullivan West 143
 Roscoe 545
 Tri-Valley 640

Tioga

Candor 085
 Dryden 152
 Ithaca 305
 Maine-Endwell 364
 Marathon 372
 Newark Valley 432
 Owego Apalachin 473
 Spencer-Van Etten 613
 Tioga 637
 Union-Endicott 651
 Vestal 658
 Waverly 676
 Whitney Point 703

Tompkins

Candor 085
 Cortland 134
 Dryden 152

Tompkins (continued)

Groton 245
 Homer 281
 Ithaca 305
 Lansing 333
 Moravia 407
 Newark Valley 432
 Newfield 436
 Odessa-Montour 460
 Southern Cayuga 609
 Spencer-Van Etten 613
 Trumansburg 643

Ulster

Ellenville 180
 Fallsburg 190
 Highland 274
 Kingston 322
 Livingston Manor 349
 Margaretville 375
 Marlboro 377
 New Paltz 427
 Onteora 466
 Pine Bush 495
 Rondout Valley 543
 Saugerties 563
 Tri-Valley 640
 Valley 405
 Wallkill 662

Warren

Abraham Wing 226
 Bolton 055
 Corinth 131
 Glens Falls 225
 Hadley-Luzerne 247
 Hudson Falls 290
 Johnsbury 312
 Lake George 327
 Minerva 399
 North Warren 451
 Queensbury 520
 Schroon Lake 573
 Ticonderoga 636
 Warrensburg 666

Washington

Argyle 020
 Cambridge 078
 Fort Ann 199
 Fort Edward 200
 Granville 233
 Greenwich 241
 Hartford 262
 Hoosick Falls 285
 Hoosick Valley 284
 Hudson Falls 290
 Lake George 327
 Putnam 517
 Salem 557
 Schuylerville 574
 Stillwater 623
 Whitehall 700

Wayne

Cato-Meridian 092
 Clyde-Savannah 118
 Gananda 213
 Lyons 360
 Marion 376
 North Rose-Wolcott 446
 Newark 431
 Palmyra-Macedon 478
 Penfield 488
 Phelps-Clifton Springs
 (Midlakes) 493
 Port Byron 507

Wayne (continued)

Red Creek 525
 Sodus 592
 Victor 659
 Wayne 678
 Webster 679
 Williamson 705

Westchester

Ardley 019
 Bedford 042
 Blind Brook 535
 Briarcliff Manor 061
 Bronxville 069
 Byram Hills 023
 Chappaqua 100
 Croton-Harmon 136
 Dobbs Ferry 147
 Eastchester 169
 Edgemont 172
 Elmsford 185
 Greenburgh Central 7 237
 Harrison 260
 Hastings-on-Hudson 263
 Hendrick Hudson 267
 Irvington 301
 Katonah-Lewisboro 316
 Lakeland 331
 Mamaroneck 367
 Mount Pleasant 417
 Mount Vernon 416
 New Rochelle 428
 North Salem 447
 Ossining 471
 Peekskill 485
 Pelham 486
 Pleasantville 504
 Pocantico Hills 505
 Port Chester 508
 Putnam Valley 518
 Rye 551
 Rye Neck 552
 Scarsdale 567
 Somers 594
 Tarrytowns 633
 Tuckahoe Union Free 644
 Valhalla 654
 White Plains 699
 Yonkers 715
 Yorktown 717

Wyoming

Alden 007
 Alexander 008
 Attica 024
 Dalton-Nunda (Keshequa) 320
 Fillmore 192
 Holland 278
 Iroquois 300
 Letchworth 339
 Pavilion 482
 Perry 490
 Pioneer 498
 Warsaw 667
 Wyoming 714
 York 716

Yates

Dundee 154
 Geneva 219
 Marcus Whitman 374
 Naples 420
 Penn Yan 489
 Prattsburg 515

2006 New York State Tax Table



Important: If your New York adjusted gross income (line 21 of Form IT-150 or line 33 of Form IT-201) is more than \$100,000, you cannot use these tables. See *Tax Computation - New York AGI of more than \$100,000* on page 54 to compute your tax. Failure to follow these instructions may result in your having to pay interest and penalty if the income tax you report on your return is less than the correct amount.



Based on Taxable Income — For purposes of this tax table, the taxable income column below is the amount on either line 26 of Form IT-150 or line 38 of Form IT-201.

Example: Mr. and Mrs. Jones are filing a joint return on Form IT-150. Their taxable income on line 26 is \$38,275. First, they find the 38,250 - 38,300 income line. Next, they find the column for **Married filing jointly** and read down the column. The amount shown where the income line and filing status column meet is \$1,844. This is the tax amount they must write on line 27 of Form IT-150.

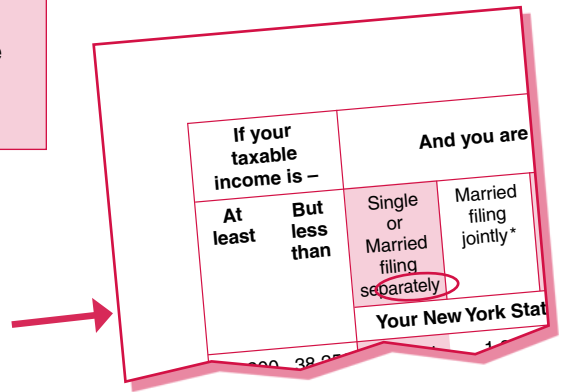

If your taxable income is –		And you are –			If your taxable income is –		And you are –			If your taxable income is –		And you are –				
At least	But less than	Single or Married filing separately	Married filing jointly*	Head of a household	At least	But less than	Single or Married filing separately	Married filing jointly*	Head of a household	At least	But less than	Single or Married filing separately	Married filing jointly*	Head of a household		
\$0	\$13	\$0	\$0	\$0	2,000			Your New York State tax is:			4,000			Your New York State tax is:		
13	25	1	1	1	2,000	2,050	81	81	81	4,000	4,050	161	161	161		
25	50	2	2	2	2,050	2,100	83	83	83	4,050	4,100	163	163	163		
50	100	3	3	3	2,100	2,150	85	85	85	4,100	4,150	165	165	165		
100	150	5	5	5	2,150	2,200	87	87	87	4,150	4,200	167	167	167		
150	200	7	7	7	2,200	2,250	89	89	89	4,200	4,250	169	169	169		
200	250	9	9	9	2,250	2,300	91	91	91	4,250	4,300	171	171	171		
250	300	11	11	11	2,300	2,350	93	93	93	4,300	4,350	173	173	173		
300	350	13	13	13	2,350	2,400	95	95	95	4,350	4,400	175	175	175		
350	400	15	15	15	2,400	2,450	97	97	97	4,400	4,450	177	177	177		
400	450	17	17	17	2,450	2,500	99	99	99	4,450	4,500	179	179	179		
450	500	19	19	19	2,500	2,550	101	101	101	4,500	4,550	181	181	181		
500	550	21	21	21	2,550	2,600	103	103	103	4,550	4,600	183	183	183		
550	600	23	23	23	2,600	2,650	105	105	105	4,600	4,650	185	185	185		
600	650	25	25	25	2,650	2,700	107	107	107	4,650	4,700	187	187	187		
650	700	27	27	27	2,700	2,750	109	109	109	4,700	4,750	189	189	189		
700	750	29	29	29	2,750	2,800	111	111	111	4,750	4,800	191	191	191		
750	800	31	31	31	2,800	2,850	113	113	113	4,800	4,850	193	193	193		
800	850	33	33	33	2,850	2,900	115	115	115	4,850	4,900	195	195	195		
850	900	35	35	35	2,900	2,950	117	117	117	4,900	4,950	197	197	197		
900	950	37	37	37	2,950	3,000	119	119	119	4,950	5,000	199	199	199		
950	1,000	39	39	39	3,000			Your New York State tax is:			5,000			Your New York State tax is:		
1,000	1,050	41	41	41	3,000	3,050	121	121	121	5,000	5,050	201	201	201		
1,050	1,100	43	43	43	3,050	3,100	123	123	123	5,050	5,100	203	203	203		
1,100	1,150	45	45	45	3,100	3,150	125	125	125	5,100	5,150	205	205	205		
1,150	1,200	47	47	47	3,150	3,200	127	127	127	5,150	5,200	207	207	207		
1,200	1,250	49	49	49	3,200	3,250	129	129	129	5,200	5,250	209	209	209		
1,250	1,300	51	51	51	3,250	3,300	131	131	131	5,250	5,300	211	211	211		
1,300	1,350	53	53	53	3,300	3,350	133	133	133	5,300	5,350	213	213	213		
1,350	1,400	55	55	55	3,350	3,400	135	135	135	5,350	5,400	215	215	215		
1,400	1,450	57	57	57	3,400	3,450	137	137	137	5,400	5,450	217	217	217		
1,450	1,500	59	59	59	3,450	3,500	139	139	139	5,450	5,500	219	219	219		
1,500	1,550	61	61	61	3,500	3,550	141	141	141	5,500	5,550	221	221	221		
1,550	1,600	63	63	63	3,550	3,600	143	143	143	5,550	5,600	223	223	223		
1,600	1,650	65	65	65	3,600	3,650	145	145	145	5,600	5,650	225	225	225		
1,650	1,700	67	67	67	3,650	3,700	147	147	147	5,650	5,700	227	227	227		
1,700	1,750	69	69	69	3,700	3,750	149	149	149	5,700	5,750	229	229	229		
1,750	1,800	71	71	71	3,750	3,800	151	151	151	5,750	5,800	231	231	231		
1,800	1,850	73	73	73	3,800	3,850	153	153	153	5,800	5,850	233	233	233		
1,850	1,900	75	75	75	3,850	3,900	155	155	155	5,850	5,900	235	235	235		
1,900	1,950	77	77	77	3,900	3,950	157	157	157	5,900	5,950	237	237	237		
1,950	2,000	79	79	79	3,950	4,000	159	159	159	5,950	6,000	239	239	239		

* This column must also be used by a qualifying widow(er)



2006 New York State Tax Table

\$6,000 – \$14,999

If your taxable income is –		And you are –			If your taxable income is –		And you are –			If your taxable income is –		And you are –		
At least	But less than	Single or Married filing separately	Married filing jointly*	Head of a household	At least	But less than	Single or Married filing separately	Married filing jointly*	Head of a household	At least	But less than	Single or Married filing separately	Married filing jointly*	Head of a household
6,000		Your New York State tax is:			9,000		Your New York State tax is:			12,000		Your New York State tax is:		
6,000	6,050	241	241	241	9,000	9,050	366	361	361	12,000	12,050	509	481	486
6,050	6,100	243	243	243	9,050	9,100	368	363	363	12,050	12,100	511	483	488
6,100	6,150	245	245	245	9,100	9,150	371	365	365	12,100	12,150	514	485	491
6,150	6,200	247	247	247	9,150	9,200	373	367	367	12,150	12,200	517	487	493
6,200	6,250	249	249	249	9,200	9,250	375	369	369	12,200	12,250	519	489	495
6,250	6,300	251	251	251	9,250	9,300	377	371	371	12,250	12,300	522	491	497
6,300	6,350	253	253	253	9,300	9,350	380	373	373	12,300	12,350	525	493	500
6,350	6,400	255	255	255	9,350	9,400	382	375	375	12,350	12,400	527	495	502
6,400	6,450	257	257	257	9,400	9,450	384	377	377	12,400	12,450	530	497	504
6,450	6,500	259	259	259	9,450	9,500	386	379	379	12,450	12,500	532	499	506
6,500	6,550	261	261	261	9,500	9,550	389	381	381	12,500	12,550	535	501	509
6,550	6,600	263	263	263	9,550	9,600	391	383	383	12,550	12,600	538	503	511
6,600	6,650	265	265	265	9,600	9,650	393	385	385	12,600	12,650	540	505	513
6,650	6,700	267	267	267	9,650	9,700	395	387	387	12,650	12,700	543	507	515
6,700	6,750	269	269	269	9,700	9,750	398	389	389	12,700	12,750	546	509	518
6,750	6,800	271	271	271	9,750	9,800	400	391	391	12,750	12,800	548	511	520
6,800	6,850	273	273	273	9,800	9,850	402	393	393	12,800	12,850	551	513	522
6,850	6,900	275	275	275	9,850	9,900	404	395	395	12,850	12,900	553	515	524
6,900	6,950	277	277	277	9,900	9,950	407	397	397	12,900	12,950	556	517	527
6,950	7,000	279	279	279	9,950	10,000	409	399	399	12,950	13,000	559	519	529
7,000		Your New York State tax is:			10,000		Your New York State tax is:			13,000		Your New York State tax is:		
7,000	7,050	281	281	281	10,000	10,050	411	401	401	13,000	13,050	561	521	531
7,050	7,100	283	283	283	10,050	10,100	413	403	403	13,050	13,100	564	523	533
7,100	7,150	285	285	285	10,100	10,150	416	405	405	13,100	13,150	567	525	536
7,150	7,200	287	287	287	10,150	10,200	418	407	407	13,150	13,200	570	527	538
7,200	7,250	289	289	289	10,200	10,250	420	409	409	13,200	13,250	573	529	540
7,250	7,300	291	291	291	10,250	10,300	422	411	411	13,250	13,300	576	531	542
7,300	7,350	293	293	293	10,300	10,350	425	413	413	13,300	13,350	579	533	545
7,350	7,400	295	295	295	10,350	10,400	427	415	415	13,350	13,400	582	535	547
7,400	7,450	297	297	297	10,400	10,450	429	417	417	13,400	13,450	585	537	549
7,450	7,500	299	299	299	10,450	10,500	431	419	419	13,450	13,500	588	539	551
7,500	7,550	301	301	301	10,500	10,550	434	421	421	13,500	13,550	591	541	554
7,550	7,600	303	303	303	10,550	10,600	436	423	423	13,550	13,600	594	543	556
7,600	7,650	305	305	305	10,600	10,650	438	425	425	13,600	13,650	597	545	558
7,650	7,700	307	307	307	10,650	10,700	440	427	427	13,650	13,700	600	547	560
7,700	7,750	309	309	309	10,700	10,750	443	429	429	13,700	13,750	603	549	563
7,750	7,800	311	311	311	10,750	10,800	445	431	431	13,750	13,800	606	551	565
7,800	7,850	313	313	313	10,800	10,850	447	433	433	13,800	13,850	609	553	567
7,850	7,900	315	315	315	10,850	10,900	449	435	435	13,850	13,900	612	555	569
7,900	7,950	317	317	317	10,900	10,950	452	437	437	13,900	13,950	615	557	572
7,950	8,000	319	319	319	10,950	11,000	454	439	439	13,950	14,000	618	559	574
8,000		Your New York State tax is:			11,000		Your New York State tax is:			14,000		Your New York State tax is:		
8,000	8,050	321	321	321	11,000	11,050	456	441	441	14,000	14,050	620	561	576
8,050	8,100	323	323	323	11,050	11,100	459	443	443	14,050	14,100	623	563	578
8,100	8,150	326	325	325	11,100	11,150	462	445	446	14,100	14,150	626	565	581
8,150	8,200	328	327	327	11,150	11,200	464	447	448	14,150	14,200	629	567	583
8,200	8,250	330	329	329	11,200	11,250	467	449	450	14,200	14,250	632	569	585
8,250	8,300	332	331	331	11,250	11,300	469	451	452	14,250	14,300	635	571	587
8,300	8,350	335	333	333	11,300	11,350	472	453	455	14,300	14,350	638	573	590
8,350	8,400	337	335	335	11,350	11,400	475	455	457	14,350	14,400	641	575	592
8,400	8,450	339	337	337	11,400	11,450	477	457	459	14,400	14,450	644	577	594
8,450	8,500	341	339	339	11,450	11,500	480	459	461	14,450	14,500	647	579	596
8,500	8,550	344	341	341	11,500	11,550	483	461	464	14,500	14,550	650	581	599
8,550	8,600	346	343	343	11,550	11,600	485	463	466	14,550	14,600	653	583	601
8,600	8,650	348	345	345	11,600	11,650	488	465	468	14,600	14,650	656	585	603
8,650	8,700	350	347	347	11,650	11,700	490	467	470	14,650	14,700	659	587	605
8,700	8,750	353	349	349	11,700	11,750	493	469	473	14,700	14,750	662	589	608
8,750	8,800	355	351	351	11,750	11,800	496	471	475	14,750	14,800	665	591	610
8,800	8,850	357	353	353	11,800	11,850	498	473	477	14,800	14,850	668	593	612
8,850	8,900	359	355	355	11,850	11,900	501	475	479	14,850	14,900	671	595	614
8,900	8,950	362	357	357	11,900	11,950	504	477	482	14,900	14,950	674	597	617
8,950	9,000	364	359	359	11,950	12,000	506	479	484	14,950	15,000	677	599	619

* This column must also be used by a qualifying widow(er)

2006 New York State Tax Table



If your taxable income is –		And you are –			If your taxable income is –		And you are –			If your taxable income is –		And you are –		
At least	But less than	Single or Married filing separately	Married filing jointly*	Head of a household	At least	But less than	Single or Married filing separately	Married filing jointly*	Head of a household	At least	But less than	Single or Married filing separately	Married filing jointly*	Head of a household
15,000		Your New York State tax is:			18,000		Your New York State tax is:			21,000		Your New York State tax is:		
15,000	15,050	679	601	621	18,000	18,050	856	731	785	21,000	21,050	1,043	866	962
15,050	15,100	682	603	624	18,050	18,100	859	733	788	21,050	21,100	1,047	868	965
15,100	15,150	685	605	627	18,100	18,150	862	736	791	21,100	21,150	1,050	871	968
15,150	15,200	688	607	629	18,150	18,200	865	738	794	21,150	21,200	1,053	873	971
15,200	15,250	691	609	632	18,200	18,250	868	740	797	21,200	21,250	1,057	875	974
15,250	15,300	694	611	634	18,250	18,300	871	742	800	21,250	21,300	1,060	877	977
15,300	15,350	697	613	637	18,300	18,350	874	745	803	21,300	21,350	1,064	880	980
15,350	15,400	700	615	640	18,350	18,400	877	747	806	21,350	21,400	1,067	882	983
15,400	15,450	703	617	642	18,400	18,450	880	749	809	21,400	21,450	1,071	884	986
15,450	15,500	706	619	645	18,450	18,500	883	751	812	21,450	21,500	1,074	886	989
15,500	15,550	709	621	648	18,500	18,550	886	754	815	21,500	21,550	1,077	889	992
15,550	15,600	712	623	650	18,550	18,600	889	756	818	21,550	21,600	1,081	891	995
15,600	15,650	715	625	653	18,600	18,650	892	758	821	21,600	21,650	1,084	893	998
15,650	15,700	718	627	655	18,650	18,700	895	760	824	21,650	21,700	1,088	895	1,001
15,700	15,750	721	629	658	18,700	18,750	898	763	827	21,700	21,750	1,091	898	1,004
15,750	15,800	724	631	661	18,750	18,800	901	765	830	21,750	21,800	1,095	900	1,007
15,800	15,850	727	633	663	18,800	18,850	904	767	833	21,800	21,850	1,098	902	1,010
15,850	15,900	730	635	666	18,850	18,900	907	769	836	21,850	21,900	1,101	904	1,013
15,900	15,950	733	637	669	18,900	18,950	910	772	839	21,900	21,950	1,105	907	1,016
15,950	16,000	736	639	671	18,950	19,000	913	774	842	21,950	22,000	1,108	909	1,019
16,000		Your New York State tax is:			19,000		Your New York State tax is:			22,000		Your New York State tax is:		
16,000	16,050	738	641	674	19,000	19,050	915	776	844	22,000	22,050	1,112	911	1,021
16,050	16,100	741	643	676	19,050	19,100	918	778	847	22,050	22,100	1,115	914	1,024
16,100	16,150	744	646	679	19,100	19,150	921	781	850	22,100	22,150	1,119	917	1,027
16,150	16,200	747	648	682	19,150	19,200	924	783	853	22,150	22,200	1,122	919	1,030
16,200	16,250	750	650	684	19,200	19,250	927	785	856	22,200	22,250	1,125	922	1,033
16,250	16,300	753	652	687	19,250	19,300	930	787	859	22,250	22,300	1,129	924	1,036
16,300	16,350	756	655	690	19,300	19,350	933	790	862	22,300	22,350	1,132	927	1,039
16,350	16,400	759	657	692	19,350	19,400	936	792	865	22,350	22,400	1,136	930	1,042
16,400	16,450	762	659	695	19,400	19,450	939	794	868	22,400	22,450	1,139	932	1,045
16,450	16,500	765	661	697	19,450	19,500	942	796	871	22,450	22,500	1,143	935	1,048
16,500	16,550	768	664	700	19,500	19,550	945	799	874	22,500	22,550	1,146	938	1,051
16,550	16,600	771	666	703	19,550	19,600	948	801	877	22,550	22,600	1,149	940	1,054
16,600	16,650	774	668	705	19,600	19,650	951	803	880	22,600	22,650	1,153	943	1,057
16,650	16,700	777	670	708	19,650	19,700	954	805	883	22,650	22,700	1,156	945	1,060
16,700	16,750	780	673	711	19,700	19,750	957	808	886	22,700	22,750	1,160	948	1,063
16,750	16,800	783	675	713	19,750	19,800	960	810	889	22,750	22,800	1,163	951	1,066
16,800	16,850	786	677	716	19,800	19,850	963	812	892	22,800	22,850	1,167	953	1,069
16,850	16,900	789	679	718	19,850	19,900	966	814	895	22,850	22,900	1,170	956	1,072
16,900	16,950	792	682	721	19,900	19,950	969	817	898	22,900	22,950	1,173	959	1,075
16,950	17,000	795	684	724	19,950	20,000	972	819	901	22,950	23,000	1,177	961	1,078
17,000		Your New York State tax is:			20,000		Your New York State tax is:			23,000		Your New York State tax is:		
17,000	17,050	797	686	726	20,000	20,050	975	821	903	23,000	23,050	1,180	964	1,080
17,050	17,100	800	688	729	20,050	20,100	978	823	906	23,050	23,100	1,184	966	1,083
17,100	17,150	803	691	732	20,100	20,150	982	826	909	23,100	23,150	1,187	969	1,086
17,150	17,200	806	693	735	20,150	20,200	985	828	912	23,150	23,200	1,190	972	1,089
17,200	17,250	809	695	738	20,200	20,250	988	830	915	23,200	23,250	1,194	974	1,092
17,250	17,300	812	697	741	20,250	20,300	992	832	918	23,250	23,300	1,197	977	1,095
17,300	17,350	815	700	744	20,300	20,350	995	835	921	23,300	23,350	1,201	980	1,098
17,350	17,400	818	702	747	20,350	20,400	999	837	924	23,350	23,400	1,204	982	1,101
17,400	17,450	821	704	750	20,400	20,450	1,002	839	927	23,400	23,450	1,208	985	1,104
17,450	17,500	824	706	753	20,450	20,500	1,006	841	930	23,450	23,500	1,211	987	1,107
17,500	17,550	827	709	756	20,500	20,550	1,009	844	933	23,500	23,550	1,214	990	1,110
17,550	17,600	830	711	759	20,550	20,600	1,012	846	936	23,550	23,600	1,218	993	1,113
17,600	17,650	833	713	762	20,600	20,650	1,016	848	939	23,600	23,650	1,221	995	1,116
17,650	17,700	836	715	765	20,650	20,700	1,019	850	942	23,650	23,700	1,225	998	1,119
17,700	17,750	839	718	768	20,700	20,750	1,023	853	945	23,700	23,750	1,228	1,001	1,122
17,750	17,800	842	720	771	20,750	20,800	1,026	855	948	23,750	23,800	1,232	1,003	1,125
17,800	17,850	845	722	774	20,800	20,850	1,030	857	951	23,800	23,850	1,235	1,006	1,128
17,850	17,900	848	724	777	20,850	20,900	1,033	859	954	23,850	23,900	1,238	1,008	1,131
17,900	17,950	851	727	780	20,900	20,950	1,036	862	957	23,900	23,950	1,242	1,011	1,134
17,950	18,000	854	729	783	20,950	21,000	1,040	864	960	23,950	24,000	1,245	1,014	1,137

* This column must also be used by a qualifying widow(er)



2006 New York State Tax Table

If your taxable income is –		And you are –			If your taxable income is –		And you are –			If your taxable income is –		And you are –		
At least	But less than	Single or Married filing separately	Married filing jointly*	Head of a household	At least	But less than	Single or Married filing separately	Married filing jointly*	Head of a household	At least	But less than	Single or Married filing separately	Married filing jointly*	Head of a household
24,000		Your New York State tax is:			27,000		Your New York State tax is:			30,000		Your New York State tax is:		
24,000	24,050	1,249	1,016	1,139	27,000	27,050	1,454	1,180	1,316	30,000	30,050	1,660	1,357	1,494
24,050	24,100	1,252	1,019	1,142	27,050	27,100	1,458	1,183	1,319	30,050	30,100	1,663	1,360	1,497
24,100	24,150	1,256	1,022	1,145	27,100	27,150	1,461	1,186	1,322	30,100	30,150	1,667	1,363	1,501
24,150	24,200	1,259	1,024	1,148	27,150	27,200	1,464	1,189	1,325	30,150	30,200	1,670	1,366	1,504
24,200	24,250	1,262	1,027	1,151	27,200	27,250	1,468	1,192	1,328	30,200	30,250	1,673	1,369	1,507
24,250	24,300	1,266	1,029	1,154	27,250	27,300	1,471	1,195	1,331	30,250	30,300	1,677	1,372	1,511
24,300	24,350	1,269	1,032	1,157	27,300	27,350	1,475	1,198	1,334	30,300	30,350	1,680	1,375	1,514
24,350	24,400	1,273	1,035	1,160	27,350	27,400	1,478	1,201	1,337	30,350	30,400	1,684	1,378	1,518
24,400	24,450	1,276	1,037	1,163	27,400	27,450	1,482	1,204	1,340	30,400	30,450	1,687	1,381	1,521
24,450	24,500	1,280	1,040	1,166	27,450	27,500	1,485	1,207	1,343	30,450	30,500	1,691	1,384	1,525
24,500	24,550	1,283	1,043	1,169	27,500	27,550	1,488	1,210	1,346	30,500	30,550	1,694	1,387	1,528
24,550	24,600	1,286	1,045	1,172	27,550	27,600	1,492	1,213	1,349	30,550	30,600	1,697	1,390	1,531
24,600	24,650	1,290	1,048	1,175	27,600	27,650	1,495	1,216	1,352	30,600	30,650	1,701	1,393	1,535
24,650	24,700	1,293	1,050	1,178	27,650	27,700	1,499	1,219	1,355	30,650	30,700	1,704	1,396	1,538
24,700	24,750	1,297	1,053	1,181	27,700	27,750	1,502	1,222	1,358	30,700	30,750	1,708	1,399	1,542
24,750	24,800	1,300	1,056	1,184	27,750	27,800	1,506	1,225	1,361	30,750	30,800	1,711	1,402	1,545
24,800	24,850	1,304	1,058	1,187	27,800	27,850	1,509	1,228	1,364	30,800	30,850	1,715	1,405	1,549
24,850	24,900	1,307	1,061	1,190	27,850	27,900	1,512	1,231	1,367	30,850	30,900	1,718	1,408	1,552
24,900	24,950	1,310	1,064	1,193	27,900	27,950	1,516	1,234	1,370	30,900	30,950	1,721	1,411	1,555
24,950	25,000	1,314	1,066	1,196	27,950	28,000	1,519	1,237	1,373	30,950	31,000	1,725	1,414	1,559
25,000		Your New York State tax is:			28,000		Your New York State tax is:			31,000		Your New York State tax is:		
25,000	25,050	1,317	1,069	1,198	28,000	28,050	1,523	1,239	1,375	31,000	31,050	1,728	1,416	1,562
25,050	25,100	1,321	1,071	1,201	28,050	28,100	1,526	1,242	1,378	31,050	31,100	1,732	1,419	1,566
25,100	25,150	1,324	1,074	1,204	28,100	28,150	1,530	1,245	1,381	31,100	31,150	1,735	1,422	1,569
25,150	25,200	1,327	1,077	1,207	28,150	28,200	1,533	1,248	1,384	31,150	31,200	1,738	1,425	1,572
25,200	25,250	1,331	1,079	1,210	28,200	28,250	1,536	1,251	1,387	31,200	31,250	1,742	1,428	1,576
25,250	25,300	1,334	1,082	1,213	28,250	28,300	1,540	1,254	1,390	31,250	31,300	1,745	1,431	1,579
25,300	25,350	1,338	1,085	1,216	28,300	28,350	1,543	1,257	1,393	31,300	31,350	1,749	1,434	1,583
25,350	25,400	1,341	1,087	1,219	28,350	28,400	1,547	1,260	1,396	31,350	31,400	1,752	1,437	1,586
25,400	25,450	1,345	1,090	1,222	28,400	28,450	1,550	1,263	1,399	31,400	31,450	1,756	1,440	1,590
25,450	25,500	1,348	1,092	1,225	28,450	28,500	1,554	1,266	1,402	31,450	31,500	1,759	1,443	1,593
25,500	25,550	1,351	1,095	1,228	28,500	28,550	1,557	1,269	1,405	31,500	31,550	1,762	1,446	1,596
25,550	25,600	1,355	1,098	1,231	28,550	28,600	1,560	1,272	1,408	31,550	31,600	1,766	1,449	1,600
25,600	25,650	1,358	1,100	1,234	28,600	28,650	1,564	1,275	1,411	31,600	31,650	1,769	1,452	1,603
25,650	25,700	1,362	1,103	1,237	28,650	28,700	1,567	1,278	1,414	31,650	31,700	1,773	1,455	1,607
25,700	25,750	1,365	1,106	1,240	28,700	28,750	1,571	1,281	1,417	31,700	31,750	1,776	1,458	1,610
25,750	25,800	1,369	1,108	1,243	28,750	28,800	1,574	1,284	1,420	31,750	31,800	1,780	1,461	1,614
25,800	25,850	1,372	1,111	1,246	28,800	28,850	1,578	1,287	1,423	31,800	31,850	1,783	1,464	1,617
25,850	25,900	1,375	1,113	1,249	28,850	28,900	1,581	1,290	1,426	31,850	31,900	1,786	1,467	1,620
25,900	25,950	1,379	1,116	1,252	28,900	28,950	1,584	1,293	1,429	31,900	31,950	1,790	1,470	1,624
25,950	26,000	1,382	1,119	1,255	28,950	29,000	1,588	1,296	1,432	31,950	32,000	1,793	1,473	1,627
26,000		Your New York State tax is:			29,000		Your New York State tax is:			32,000		Your New York State tax is:		
26,000	26,050	1,386	1,121	1,257	29,000	29,050	1,591	1,298	1,434	32,000	32,050	1,797	1,475	1,631
26,050	26,100	1,389	1,124	1,260	29,050	29,100	1,595	1,301	1,437	32,050	32,100	1,800	1,478	1,634
26,100	26,150	1,393	1,127	1,263	29,100	29,150	1,598	1,304	1,440	32,100	32,150	1,804	1,481	1,638
26,150	26,200	1,396	1,130	1,266	29,150	29,200	1,601	1,307	1,443	32,150	32,200	1,807	1,484	1,641
26,200	26,250	1,399	1,133	1,269	29,200	29,250	1,605	1,310	1,446	32,200	32,250	1,810	1,487	1,644
26,250	26,300	1,403	1,136	1,272	29,250	29,300	1,608	1,313	1,449	32,250	32,300	1,814	1,490	1,648
26,300	26,350	1,406	1,139	1,275	29,300	29,350	1,612	1,316	1,452	32,300	32,350	1,817	1,493	1,651
26,350	26,400	1,410	1,142	1,278	29,350	29,400	1,615	1,319	1,455	32,350	32,400	1,821	1,496	1,655
26,400	26,450	1,413	1,145	1,281	29,400	29,450	1,619	1,322	1,458	32,400	32,450	1,824	1,499	1,658
26,450	26,500	1,417	1,148	1,284	29,450	29,500	1,622	1,325	1,461	32,450	32,500	1,828	1,502	1,662
26,500	26,550	1,420	1,151	1,287	29,500	29,550	1,625	1,328	1,464	32,500	32,550	1,831	1,505	1,665
26,550	26,600	1,423	1,154	1,290	29,550	29,600	1,629	1,331	1,467	32,550	32,600	1,834	1,508	1,668
26,600	26,650	1,427	1,157	1,293	29,600	29,650	1,632	1,334	1,470	32,600	32,650	1,838	1,511	1,672
26,650	26,700	1,430	1,160	1,296	29,650	29,700	1,636	1,337	1,473	32,650	32,700	1,841	1,514	1,675
26,700	26,750	1,434	1,163	1,299	29,700	29,750	1,639	1,340	1,476	32,700	32,750	1,845	1,517	1,679
26,750	26,800	1,437	1,166	1,302	29,750	29,800	1,643	1,343	1,479	32,750	32,800	1,848	1,520	1,682
26,800	26,850	1,441	1,169	1,305	29,800	29,850	1,646	1,346	1,482	32,800	32,850	1,852	1,523	1,686
26,850	26,900	1,444	1,172	1,308	29,850	29,900	1,649	1,349	1,485	32,850	32,900	1,855	1,526	1,689
26,900	26,950	1,447	1,175	1,311	29,900	29,950	1,653	1,352	1,488	32,900	32,950	1,858	1,529	1,692
26,950	27,000	1,451	1,178	1,314	29,950	30,000	1,656	1,355	1,491	32,950	33,000	1,862	1,532	1,696

* This column must also be used by a qualifying widow(er)

2006 New York State Tax Table



If your taxable income is –		And you are –			If your taxable income is –		And you are –			If your taxable income is –		And you are –		
At least	But less than	Single or Married filing separately	Married filing jointly*	Head of a household	At least	But less than	Single or Married filing separately	Married filing jointly*	Head of a household	At least	But less than	Single or Married filing separately	Married filing jointly*	Head of a household
33,000		Your New York State tax is:			36,000		Your New York State tax is:			39,000		Your New York State tax is:		
33,000	33,050	1,865	1,534	1,699	36,000	36,050	2,071	1,711	1,905	39,000	39,050	2,276	1,888	2,110
33,050	33,100	1,869	1,537	1,703	36,050	36,100	2,074	1,714	1,908	39,050	39,100	2,280	1,891	2,114
33,100	33,150	1,872	1,540	1,706	36,100	36,150	2,078	1,717	1,912	39,100	39,150	2,283	1,894	2,117
33,150	33,200	1,875	1,543	1,709	36,150	36,200	2,081	1,720	1,915	39,150	39,200	2,286	1,897	2,120
33,200	33,250	1,879	1,546	1,713	36,200	36,250	2,084	1,723	1,918	39,200	39,250	2,290	1,900	2,124
33,250	33,300	1,882	1,549	1,716	36,250	36,300	2,088	1,726	1,922	39,250	39,300	2,293	1,903	2,127
33,300	33,350	1,886	1,552	1,720	36,300	36,350	2,091	1,729	1,925	39,300	39,350	2,297	1,906	2,131
33,350	33,400	1,889	1,555	1,723	36,350	36,400	2,095	1,732	1,929	39,350	39,400	2,300	1,909	2,134
33,400	33,450	1,893	1,558	1,727	36,400	36,450	2,098	1,735	1,932	39,400	39,450	2,304	1,912	2,138
33,450	33,500	1,896	1,561	1,730	36,450	36,500	2,102	1,738	1,936	39,450	39,500	2,307	1,915	2,141
33,500	33,550	1,899	1,564	1,733	36,500	36,550	2,105	1,741	1,939	39,500	39,550	2,310	1,918	2,144
33,550	33,600	1,903	1,567	1,737	36,550	36,600	2,108	1,744	1,942	39,550	39,600	2,314	1,921	2,148
33,600	33,650	1,906	1,570	1,740	36,600	36,650	2,112	1,747	1,946	39,600	39,650	2,317	1,924	2,151
33,650	33,700	1,910	1,573	1,744	36,650	36,700	2,115	1,750	1,949	39,650	39,700	2,321	1,927	2,155
33,700	33,750	1,913	1,576	1,747	36,700	36,750	2,119	1,753	1,953	39,700	39,750	2,324	1,930	2,158
33,750	33,800	1,917	1,579	1,751	36,750	36,800	2,122	1,756	1,956	39,750	39,800	2,328	1,933	2,162
33,800	33,850	1,920	1,582	1,754	36,800	36,850	2,126	1,759	1,960	39,800	39,850	2,331	1,936	2,165
33,850	33,900	1,923	1,585	1,757	36,850	36,900	2,129	1,762	1,963	39,850	39,900	2,334	1,939	2,168
33,900	33,950	1,927	1,588	1,761	36,900	36,950	2,132	1,765	1,966	39,900	39,950	2,338	1,942	2,172
33,950	34,000	1,930	1,591	1,764	36,950	37,000	2,136	1,768	1,970	39,950	40,000	2,341	1,945	2,175
34,000		Your New York State tax is:			37,000		Your New York State tax is:			40,000		Your New York State tax is:		
34,000	34,050	1,934	1,593	1,768	37,000	37,050	2,139	1,770	1,973	40,000	40,050	2,345	1,948	2,179
34,050	34,100	1,937	1,596	1,771	37,050	37,100	2,143	1,773	1,977	40,050	40,100	2,348	1,951	2,182
34,100	34,150	1,941	1,599	1,775	37,100	37,150	2,146	1,776	1,980	40,100	40,150	2,352	1,955	2,186
34,150	34,200	1,944	1,602	1,778	37,150	37,200	2,149	1,779	1,983	40,150	40,200	2,355	1,958	2,189
34,200	34,250	1,947	1,605	1,781	37,200	37,250	2,153	1,782	1,987	40,200	40,250	2,358	1,961	2,192
34,250	34,300	1,951	1,608	1,785	37,250	37,300	2,156	1,785	1,990	40,250	40,300	2,362	1,965	2,196
34,300	34,350	1,954	1,611	1,788	37,300	37,350	2,160	1,788	1,994	40,300	40,350	2,365	1,968	2,199
34,350	34,400	1,958	1,614	1,792	37,350	37,400	2,163	1,791	1,997	40,350	40,400	2,369	1,972	2,203
34,400	34,450	1,961	1,617	1,795	37,400	37,450	2,167	1,794	2,001	40,400	40,450	2,372	1,975	2,206
34,450	34,500	1,965	1,620	1,799	37,450	37,500	2,170	1,797	2,004	40,450	40,500	2,376	1,979	2,210
34,500	34,550	1,968	1,623	1,802	37,500	37,550	2,173	1,800	2,007	40,500	40,550	2,379	1,982	2,213
34,550	34,600	1,971	1,626	1,805	37,550	37,600	2,177	1,803	2,011	40,550	40,600	2,382	1,985	2,216
34,600	34,650	1,975	1,629	1,809	37,600	37,650	2,180	1,806	2,014	40,600	40,650	2,386	1,989	2,220
34,650	34,700	1,978	1,632	1,812	37,650	37,700	2,184	1,809	2,018	40,650	40,700	2,389	1,992	2,223
34,700	34,750	1,982	1,635	1,816	37,700	37,750	2,187	1,812	2,021	40,700	40,750	2,393	1,996	2,227
34,750	34,800	1,985	1,638	1,819	37,750	37,800	2,191	1,815	2,025	40,750	40,800	2,396	1,999	2,230
34,800	34,850	1,989	1,641	1,823	37,800	37,850	2,194	1,818	2,028	40,800	40,850	2,400	2,003	2,234
34,850	34,900	1,992	1,644	1,826	37,850	37,900	2,197	1,821	2,031	40,850	40,900	2,403	2,006	2,237
34,900	34,950	1,995	1,647	1,829	37,900	37,950	2,201	1,824	2,035	40,900	40,950	2,406	2,009	2,240
34,950	35,000	1,999	1,650	1,833	37,950	38,000	2,204	1,827	2,038	40,950	41,000	2,410	2,013	2,244
35,000		Your New York State tax is:			38,000		Your New York State tax is:			41,000		Your New York State tax is:		
35,000	35,050	2,002	1,652	1,836	38,000	38,050	2,208	1,829	2,042	41,000	41,050	2,413	2,016	2,247
35,050	35,100	2,006	1,655	1,840	38,050	38,100	2,211	1,832	2,045	41,050	41,100	2,417	2,020	2,251
35,100	35,150	2,009	1,658	1,843	38,100	38,150	2,215	1,835	2,049	41,100	41,150	2,420	2,023	2,254
35,150	35,200	2,012	1,661	1,846	38,150	38,200	2,218	1,838	2,052	41,150	41,200	2,423	2,026	2,257
35,200	35,250	2,016	1,664	1,850	38,200	38,250	2,221	1,841	2,055	41,200	41,250	2,427	2,030	2,261
35,250	35,300	2,019	1,667	1,853	38,250	38,300	2,225	1,844	2,059	41,250	41,300	2,430	2,033	2,264
35,300	35,350	2,023	1,670	1,857	38,300	38,350	2,228	1,847	2,062	41,300	41,350	2,434	2,037	2,268
35,350	35,400	2,026	1,673	1,860	38,350	38,400	2,232	1,850	2,066	41,350	41,400	2,437	2,040	2,271
35,400	35,450	2,030	1,676	1,864	38,400	38,450	2,235	1,853	2,069	41,400	41,450	2,441	2,044	2,275
35,450	35,500	2,033	1,679	1,867	38,450	38,500	2,239	1,856	2,073	41,450	41,500	2,444	2,047	2,278
35,500	35,550	2,036	1,682	1,870	38,500	38,550	2,242	1,859	2,076	41,500	41,550	2,447	2,050	2,281
35,550	35,600	2,040	1,685	1,874	38,550	38,600	2,245	1,862	2,079	41,550	41,600	2,451	2,054	2,285
35,600	35,650	2,043	1,688	1,877	38,600	38,650	2,249	1,865	2,083	41,600	41,650	2,454	2,057	2,288
35,650	35,700	2,047	1,691	1,881	38,650	38,700	2,252	1,868	2,086	41,650	41,700	2,458	2,061	2,292
35,700	35,750	2,050	1,694	1,884	38,700	38,750	2,256	1,871	2,090	41,700	41,750	2,461	2,064	2,295
35,750	35,800	2,054	1,697	1,888	38,750	38,800	2,259	1,874	2,093	41,750	41,800	2,465	2,068	2,299
35,800	35,850	2,057	1,700	1,891	38,800	38,850	2,263	1,877	2,097	41,800	41,850	2,468	2,071	2,302
35,850	35,900	2,060	1,703	1,894	38,850	38,900	2,266	1,880	2,100	41,850	41,900	2,471	2,074	2,305
35,900	35,950	2,064	1,706	1,898	38,900	38,950	2,269	1,883	2,103	41,900	41,950	2,475	2,078	2,309
35,950	36,000	2,067	1,709	1,901	38,950	39,000	2,273	1,886	2,107	41,950	42,000	2,478	2,081	2,312

* This column must also be used by a qualifying widow(er)



2006 New York State Tax Table

\$42,000 – \$50,999 51

If your taxable income is –		And you are –			If your taxable income is –		And you are –			If your taxable income is –		And you are –		
At least	But less than	Single or Married filing separately	Married filing jointly*	Head of a household	At least	But less than	Single or Married filing separately	Married filing jointly*	Head of a household	At least	But less than	Single or Married filing separately	Married filing jointly*	Head of a household
42,000		Your New York State tax is:			45,000		Your New York State tax is:			48,000		Your New York State tax is:		
42,000	42,050	2,482	2,085	2,316	45,000	45,050	2,687	2,290	2,521	48,000	48,050	2,893	2,496	2,727
42,050	42,100	2,485	2,088	2,319	45,050	45,100	2,691	2,294	2,525	48,050	48,100	2,896	2,499	2,730
42,100	42,150	2,489	2,092	2,323	45,100	45,150	2,694	2,297	2,528	48,100	48,150	2,900	2,503	2,734
42,150	42,200	2,492	2,095	2,326	45,150	45,200	2,697	2,300	2,531	48,150	48,200	2,903	2,506	2,737
42,200	42,250	2,495	2,098	2,329	45,200	45,250	2,701	2,304	2,535	48,200	48,250	2,906	2,509	2,740
42,250	42,300	2,499	2,102	2,333	45,250	45,300	2,704	2,307	2,538	48,250	48,300	2,910	2,513	2,744
42,300	42,350	2,502	2,105	2,336	45,300	45,350	2,708	2,311	2,542	48,300	48,350	2,913	2,516	2,747
42,350	42,400	2,506	2,109	2,340	45,350	45,400	2,711	2,314	2,545	48,350	48,400	2,917	2,520	2,751
42,400	42,450	2,509	2,112	2,343	45,400	45,450	2,715	2,318	2,549	48,400	48,450	2,920	2,523	2,754
42,450	42,500	2,513	2,116	2,347	45,450	45,500	2,718	2,321	2,552	48,450	48,500	2,924	2,527	2,758
42,500	42,550	2,516	2,119	2,350	45,500	45,550	2,721	2,324	2,555	48,500	48,550	2,927	2,530	2,761
42,550	42,600	2,519	2,122	2,353	45,550	45,600	2,725	2,328	2,559	48,550	48,600	2,930	2,533	2,764
42,600	42,650	2,523	2,126	2,357	45,600	45,650	2,728	2,331	2,562	48,600	48,650	2,934	2,537	2,768
42,650	42,700	2,526	2,129	2,360	45,650	45,700	2,732	2,335	2,566	48,650	48,700	2,937	2,540	2,771
42,700	42,750	2,530	2,133	2,364	45,700	45,750	2,735	2,338	2,569	48,700	48,750	2,941	2,544	2,775
42,750	42,800	2,533	2,136	2,367	45,750	45,800	2,739	2,342	2,573	48,750	48,800	2,944	2,547	2,778
42,800	42,850	2,537	2,140	2,371	45,800	45,850	2,742	2,345	2,576	48,800	48,850	2,948	2,551	2,782
42,850	42,900	2,540	2,143	2,374	45,850	45,900	2,745	2,348	2,579	48,850	48,900	2,951	2,554	2,785
42,900	42,950	2,543	2,146	2,377	45,900	45,950	2,749	2,352	2,583	48,900	48,950	2,954	2,557	2,788
42,950	43,000	2,547	2,150	2,381	45,950	46,000	2,752	2,355	2,586	48,950	49,000	2,958	2,561	2,792
43,000		Your New York State tax is:			46,000		Your New York State tax is:			49,000		Your New York State tax is:		
43,000	43,050	2,550	2,153	2,384	46,000	46,050	2,756	2,359	2,590	49,000	49,050	2,961	2,564	2,795
43,050	43,100	2,554	2,157	2,388	46,050	46,100	2,759	2,362	2,593	49,050	49,100	2,965	2,568	2,799
43,100	43,150	2,557	2,160	2,391	46,100	46,150	2,763	2,366	2,597	49,100	49,150	2,968	2,571	2,802
43,150	43,200	2,560	2,163	2,394	46,150	46,200	2,766	2,369	2,600	49,150	49,200	2,971	2,574	2,805
43,200	43,250	2,564	2,167	2,398	46,200	46,250	2,769	2,372	2,603	49,200	49,250	2,975	2,578	2,809
43,250	43,300	2,567	2,170	2,401	46,250	46,300	2,773	2,376	2,607	49,250	49,300	2,978	2,581	2,812
43,300	43,350	2,571	2,174	2,405	46,300	46,350	2,776	2,379	2,610	49,300	49,350	2,982	2,585	2,816
43,350	43,400	2,574	2,177	2,408	46,350	46,400	2,780	2,383	2,614	49,350	49,400	2,985	2,588	2,819
43,400	43,450	2,578	2,181	2,412	46,400	46,450	2,783	2,386	2,617	49,400	49,450	2,989	2,592	2,823
43,450	43,500	2,581	2,184	2,415	46,450	46,500	2,787	2,390	2,621	49,450	49,500	2,992	2,595	2,826
43,500	43,550	2,584	2,187	2,418	46,500	46,550	2,790	2,393	2,624	49,500	49,550	2,995	2,598	2,829
43,550	43,600	2,588	2,191	2,422	46,550	46,600	2,793	2,396	2,627	49,550	49,600	2,999	2,602	2,833
43,600	43,650	2,591	2,194	2,425	46,600	46,650	2,797	2,400	2,631	49,600	49,650	3,002	2,605	2,836
43,650	43,700	2,595	2,198	2,429	46,650	46,700	2,800	2,403	2,634	49,650	49,700	3,006	2,609	2,840
43,700	43,750	2,598	2,201	2,432	46,700	46,750	2,804	2,407	2,638	49,700	49,750	3,009	2,612	2,843
43,750	43,800	2,602	2,205	2,436	46,750	46,800	2,807	2,410	2,641	49,750	49,800	3,013	2,616	2,847
43,800	43,850	2,605	2,208	2,439	46,800	46,850	2,811	2,414	2,645	49,800	49,850	3,016	2,619	2,850
43,850	43,900	2,608	2,211	2,442	46,850	46,900	2,814	2,417	2,648	49,850	49,900	3,019	2,622	2,853
43,900	43,950	2,612	2,215	2,446	46,900	46,950	2,817	2,420	2,651	49,900	49,950	3,023	2,626	2,857
43,950	44,000	2,615	2,218	2,449	46,950	47,000	2,821	2,424	2,655	49,950	50,000	3,026	2,629	2,860
44,000		Your New York State tax is:			47,000		Your New York State tax is:			50,000		Your New York State tax is:		
44,000	44,050	2,619	2,222	2,453	47,000	47,050	2,824	2,427	2,658	50,000	50,050	3,030	2,633	2,864
44,050	44,100	2,622	2,225	2,456	47,050	47,100	2,828	2,431	2,662	50,050	50,100	3,033	2,636	2,867
44,100	44,150	2,626	2,229	2,460	47,100	47,150	2,831	2,434	2,665	50,100	50,150	3,037	2,640	2,871
44,150	44,200	2,629	2,232	2,463	47,150	47,200	2,834	2,437	2,668	50,150	50,200	3,040	2,643	2,874
44,200	44,250	2,632	2,235	2,466	47,200	47,250	2,838	2,441	2,672	50,200	50,250	3,043	2,646	2,877
44,250	44,300	2,636	2,239	2,470	47,250	47,300	2,841	2,444	2,675	50,250	50,300	3,047	2,650	2,881
44,300	44,350	2,639	2,242	2,473	47,300	47,350	2,845	2,448	2,679	50,300	50,350	3,050	2,653	2,884
44,350	44,400	2,643	2,246	2,477	47,350	47,400	2,848	2,451	2,682	50,350	50,400	3,054	2,657	2,888
44,400	44,450	2,646	2,249	2,480	47,400	47,450	2,852	2,455	2,686	50,400	50,450	3,057	2,660	2,891
44,450	44,500	2,650	2,253	2,484	47,450	47,500	2,855	2,458	2,689	50,450	50,500	3,061	2,664	2,895
44,500	44,550	2,653	2,256	2,487	47,500	47,550	2,858	2,461	2,692	50,500	50,550	3,064	2,667	2,898
44,550	44,600	2,656	2,259	2,490	47,550	47,600	2,862	2,465	2,696	50,550	50,600	3,067	2,670	2,901
44,600	44,650	2,660	2,263	2,494	47,600	47,650	2,865	2,468	2,699	50,600	50,650	3,071	2,674	2,905
44,650	44,700	2,663	2,266	2,497	47,650	47,700	2,869	2,472	2,703	50,650	50,700	3,074	2,677	2,908
44,700	44,750	2,667	2,270	2,501	47,700	47,750	2,872	2,475	2,706	50,700	50,750	3,078	2,681	2,912
44,750	44,800	2,670	2,273	2,504	47,750	47,800	2,876	2,479	2,710	50,750	50,800	3,081	2,684	2,915
44,800	44,850	2,674	2,277	2,508	47,800	47,850	2,879	2,482	2,713	50,800	50,850	3,085	2,688	2,919
44,850	44,900	2,677	2,280	2,511	47,850	47,900	2,882	2,485	2,716	50,850	50,900	3,088	2,691	2,922
44,900	44,950	2,680	2,283	2,514	47,900	47,950	2,886	2,489	2,720	50,900	50,950	3,091	2,694	2,925
44,950	45,000	2,684	2,287	2,518	47,950	48,000	2,889	2,492	2,723	50,950	51,000	3,095	2,698	2,929

* This column must also be used by a qualifying widow(er)

2006 New York State Tax Table



If your taxable income is –		And you are –			If your taxable income is –		And you are –			If your taxable income is –		And you are –		
At least	But less than	Single or Married filing separately	Married filing jointly*	Head of a household	At least	But less than	Single or Married filing separately	Married filing jointly*	Head of a household	At least	But less than	Single or Married filing separately	Married filing jointly*	Head of a household
51,000		Your New York State tax is:			54,000		Your New York State tax is:			57,000		Your New York State tax is:		
51,000	51,050	3,098	2,701	2,932	54,000	54,050	3,304	2,907	3,138	57,000	57,050	3,509	3,112	3,343
51,050	51,100	3,102	2,705	2,936	54,050	54,100	3,307	2,910	3,141	57,050	57,100	3,513	3,116	3,347
51,100	51,150	3,105	2,708	2,939	54,100	54,150	3,311	2,914	3,145	57,100	57,150	3,516	3,119	3,350
51,150	51,200	3,108	2,711	2,942	54,150	54,200	3,314	2,917	3,148	57,150	57,200	3,519	3,122	3,353
51,200	51,250	3,112	2,715	2,946	54,200	54,250	3,317	2,920	3,151	57,200	57,250	3,523	3,126	3,357
51,250	51,300	3,115	2,718	2,949	54,250	54,300	3,321	2,924	3,155	57,250	57,300	3,526	3,129	3,360
51,300	51,350	3,119	2,722	2,953	54,300	54,350	3,324	2,927	3,158	57,300	57,350	3,530	3,133	3,364
51,350	51,400	3,122	2,725	2,956	54,350	54,400	3,328	2,931	3,162	57,350	57,400	3,533	3,136	3,367
51,400	51,450	3,126	2,729	2,960	54,400	54,450	3,331	2,934	3,165	57,400	57,450	3,537	3,140	3,371
51,450	51,500	3,129	2,732	2,963	54,450	54,500	3,335	2,938	3,169	57,450	57,500	3,540	3,143	3,374
51,500	51,550	3,132	2,735	2,966	54,500	54,550	3,338	2,941	3,172	57,500	57,550	3,543	3,146	3,377
51,550	51,600	3,136	2,739	2,970	54,550	54,600	3,341	2,944	3,175	57,550	57,600	3,547	3,150	3,381
51,600	51,650	3,139	2,742	2,973	54,600	54,650	3,345	2,948	3,179	57,600	57,650	3,550	3,153	3,384
51,650	51,700	3,143	2,746	2,977	54,650	54,700	3,348	2,951	3,182	57,650	57,700	3,554	3,157	3,388
51,700	51,750	3,146	2,749	2,980	54,700	54,750	3,352	2,955	3,186	57,700	57,750	3,557	3,160	3,391
51,750	51,800	3,150	2,753	2,984	54,750	54,800	3,355	2,958	3,189	57,750	57,800	3,561	3,164	3,395
51,800	51,850	3,153	2,756	2,987	54,800	54,850	3,359	2,962	3,193	57,800	57,850	3,564	3,167	3,398
51,850	51,900	3,156	2,759	2,990	54,850	54,900	3,362	2,965	3,196	57,850	57,900	3,567	3,170	3,401
51,900	51,950	3,160	2,763	2,994	54,900	54,950	3,365	2,968	3,199	57,900	57,950	3,571	3,174	3,405
51,950	52,000	3,163	2,766	2,997	54,950	55,000	3,369	2,972	3,203	57,950	58,000	3,574	3,177	3,408
52,000		Your New York State tax is:			55,000		Your New York State tax is:			58,000		Your New York State tax is:		
52,000	52,050	3,167	2,770	3,001	55,000	55,050	3,372	2,975	3,206	58,000	58,050	3,578	3,181	3,412
52,050	52,100	3,170	2,773	3,004	55,050	55,100	3,376	2,979	3,210	58,050	58,100	3,581	3,184	3,415
52,100	52,150	3,174	2,777	3,008	55,100	55,150	3,379	2,982	3,213	58,100	58,150	3,585	3,188	3,419
52,150	52,200	3,177	2,780	3,011	55,150	55,200	3,382	2,985	3,216	58,150	58,200	3,588	3,191	3,422
52,200	52,250	3,180	2,783	3,014	55,200	55,250	3,386	2,989	3,220	58,200	58,250	3,591	3,194	3,425
52,250	52,300	3,184	2,787	3,018	55,250	55,300	3,389	2,992	3,223	58,250	58,300	3,595	3,198	3,429
52,300	52,350	3,187	2,790	3,021	55,300	55,350	3,393	2,996	3,227	58,300	58,350	3,598	3,201	3,432
52,350	52,400	3,191	2,794	3,025	55,350	55,400	3,396	2,999	3,230	58,350	58,400	3,602	3,205	3,436
52,400	52,450	3,194	2,797	3,028	55,400	55,450	3,400	3,003	3,234	58,400	58,450	3,605	3,208	3,439
52,450	52,500	3,198	2,801	3,032	55,450	55,500	3,403	3,006	3,237	58,450	58,500	3,609	3,212	3,443
52,500	52,550	3,201	2,804	3,035	55,500	55,550	3,406	3,009	3,240	58,500	58,550	3,612	3,215	3,446
52,550	52,600	3,204	2,807	3,038	55,550	55,600	3,410	3,013	3,244	58,550	58,600	3,615	3,218	3,449
52,600	52,650	3,208	2,811	3,042	55,600	55,650	3,413	3,016	3,247	58,600	58,650	3,619	3,222	3,453
52,650	52,700	3,211	2,814	3,045	55,650	55,700	3,417	3,020	3,251	58,650	58,700	3,622	3,225	3,456
52,700	52,750	3,215	2,818	3,049	55,700	55,750	3,420	3,023	3,254	58,700	58,750	3,626	3,229	3,460
52,750	52,800	3,218	2,821	3,052	55,750	55,800	3,424	3,027	3,258	58,750	58,800	3,629	3,232	3,463
52,800	52,850	3,222	2,825	3,056	55,800	55,850	3,427	3,030	3,261	58,800	58,850	3,633	3,236	3,467
52,850	52,900	3,225	2,828	3,059	55,850	55,900	3,430	3,033	3,264	58,850	58,900	3,636	3,239	3,470
52,900	52,950	3,228	2,831	3,062	55,900	55,950	3,434	3,037	3,268	58,900	58,950	3,639	3,242	3,473
52,950	53,000	3,232	2,835	3,066	55,950	56,000	3,437	3,040	3,271	58,950	59,000	3,643	3,246	3,477
53,000		Your New York State tax is:			56,000		Your New York State tax is:			59,000		Your New York State tax is:		
53,000	53,050	3,235	2,838	3,069	56,000	56,050	3,441	3,044	3,275	59,000	59,050	3,646	3,249	3,480
53,050	53,100	3,239	2,842	3,073	56,050	56,100	3,444	3,047	3,278	59,050	59,100	3,650	3,253	3,484
53,100	53,150	3,242	2,845	3,076	56,100	56,150	3,448	3,051	3,282	59,100	59,150	3,653	3,256	3,487
53,150	53,200	3,245	2,848	3,079	56,150	56,200	3,451	3,054	3,285	59,150	59,200	3,656	3,259	3,490
53,200	53,250	3,249	2,852	3,083	56,200	56,250	3,454	3,057	3,288	59,200	59,250	3,660	3,263	3,494
53,250	53,300	3,252	2,855	3,086	56,250	56,300	3,458	3,061	3,292	59,250	59,300	3,663	3,266	3,497
53,300	53,350	3,256	2,859	3,090	56,300	56,350	3,461	3,064	3,295	59,300	59,350	3,667	3,270	3,501
53,350	53,400	3,259	2,862	3,093	56,350	56,400	3,465	3,068	3,299	59,350	59,400	3,670	3,273	3,504
53,400	53,450	3,263	2,866	3,097	56,400	56,450	3,468	3,071	3,302	59,400	59,450	3,674	3,277	3,508
53,450	53,500	3,266	2,869	3,100	56,450	56,500	3,472	3,075	3,306	59,450	59,500	3,677	3,280	3,511
53,500	53,550	3,269	2,872	3,103	56,500	56,550	3,475	3,078	3,309	59,500	59,550	3,680	3,283	3,514
53,550	53,600	3,273	2,876	3,107	56,550	56,600	3,478	3,081	3,312	59,550	59,600	3,684	3,287	3,518
53,600	53,650	3,276	2,879	3,110	56,600	56,650	3,482	3,085	3,316	59,600	59,650	3,687	3,290	3,521
53,650	53,700	3,280	2,883	3,114	56,650	56,700	3,485	3,088	3,319	59,650	59,700	3,691	3,294	3,525
53,700	53,750	3,283	2,886	3,117	56,700	56,750	3,489	3,092	3,323	59,700	59,750	3,694	3,297	3,528
53,750	53,800	3,287	2,890	3,121	56,750	56,800	3,492	3,095	3,326	59,750	59,800	3,698	3,301	3,532
53,800	53,850	3,290	2,893	3,124	56,800	56,850	3,496	3,099	3,330	59,800	59,850	3,701	3,304	3,535
53,850	53,900	3,293	2,896	3,127	56,850	56,900	3,499	3,102	3,333	59,850	59,900	3,704	3,307	3,538
53,900	53,950	3,297	2,900	3,131	56,900	56,950	3,502	3,105	3,336	59,900	59,950	3,708	3,311	3,542
53,950	54,000	3,300	2,903	3,134	56,950	57,000	3,506	3,109	3,340	59,950	60,000	3,711	3,314	3,545

* This column must also be used by a qualifying widow(er)



2006 New York State Tax Table

If your taxable income is –		And you are –			If your taxable income is –		And you are –			If your taxable income is –		And you are –		
At least	But less than	Single or Married filing separately	Married filing jointly*	Head of a household	At least	But less than	Single or Married filing separately	Married filing jointly*	Head of a household	At least	But less than	Single or Married filing separately	Married filing jointly*	Head of a household
60,000		Your New York State tax is:			62,000		Your New York State tax is:			64,000		Your New York State tax is:		
60,000	60,050	3,715	3,318	3,549	62,000	62,050	3,852	3,455	3,686	64,000	64,050	3,989	3,592	3,823
60,050	60,100	3,718	3,321	3,552	62,050	62,100	3,855	3,458	3,689	64,050	64,100	3,992	3,595	3,826
60,100	60,150	3,722	3,325	3,556	62,100	62,150	3,859	3,462	3,693	64,100	64,150	3,996	3,599	3,830
60,150	60,200	3,725	3,328	3,559	62,150	62,200	3,862	3,465	3,696	64,150	64,200	3,999	3,602	3,833
60,200	60,250	3,728	3,331	3,562	62,200	62,250	3,865	3,468	3,699	64,200	64,250	4,002	3,605	3,836
60,250	60,300	3,732	3,335	3,566	62,250	62,300	3,869	3,472	3,703	64,250	64,300	4,006	3,609	3,840
60,300	60,350	3,735	3,338	3,569	62,300	62,350	3,872	3,475	3,706	64,300	64,350	4,009	3,612	3,843
60,350	60,400	3,739	3,342	3,573	62,350	62,400	3,876	3,479	3,710	64,350	64,400	4,013	3,616	3,847
60,400	60,450	3,742	3,345	3,576	62,400	62,450	3,879	3,482	3,713	64,400	64,450	4,016	3,619	3,850
60,450	60,500	3,746	3,349	3,580	62,450	62,500	3,883	3,486	3,717	64,450	64,500	4,020	3,623	3,854
60,500	60,550	3,749	3,352	3,583	62,500	62,550	3,886	3,489	3,720	64,500	64,550	4,023	3,626	3,857
60,550	60,600	3,752	3,355	3,586	62,550	62,600	3,889	3,492	3,723	64,550	64,600	4,026	3,629	3,860
60,600	60,650	3,756	3,359	3,590	62,600	62,650	3,893	3,496	3,727	64,600	64,650	4,030	3,633	3,864
60,650	60,700	3,759	3,362	3,593	62,650	62,700	3,896	3,499	3,730	64,650	64,700	4,033	3,636	3,867
60,700	60,750	3,763	3,366	3,597	62,700	62,750	3,900	3,503	3,734	64,700	64,750	4,037	3,640	3,871
60,750	60,800	3,766	3,369	3,600	62,750	62,800	3,903	3,506	3,737	64,750	64,800	4,040	3,643	3,874
60,800	60,850	3,770	3,373	3,604	62,800	62,850	3,907	3,510	3,741	64,800	64,850	4,044	3,647	3,878
60,850	60,900	3,773	3,376	3,607	62,850	62,900	3,910	3,513	3,744	64,850	64,900	4,047	3,650	3,881
60,900	60,950	3,776	3,379	3,610	62,900	62,950	3,913	3,516	3,747	64,900	64,950	4,050	3,653	3,884
60,950	61,000	3,780	3,383	3,614	62,950	63,000	3,917	3,520	3,751	64,950	65,000	4,054	3,657	3,888
61,000		Your New York State tax is:			63,000		Your New York State tax is:			65,000 or more:				
61,000	61,050	3,783	3,386	3,617	63,000	63,050	3,920	3,523	3,754					
61,050	61,100	3,787	3,390	3,621	63,050	63,100	3,924	3,527	3,758					
61,100	61,150	3,790	3,393	3,624	63,100	63,150	3,927	3,530	3,761					
61,150	61,200	3,793	3,396	3,627	63,150	63,200	3,930	3,533	3,764					
61,200	61,250	3,797	3,400	3,631	63,200	63,250	3,934	3,537	3,768					
61,250	61,300	3,800	3,403	3,634	63,250	63,300	3,937	3,540	3,771					
61,300	61,350	3,804	3,407	3,638	63,300	63,350	3,941	3,544	3,775					
61,350	61,400	3,807	3,410	3,641	63,350	63,400	3,944	3,547	3,778					
61,400	61,450	3,811	3,414	3,645	63,400	63,450	3,948	3,551	3,782					
61,450	61,500	3,814	3,417	3,648	63,450	63,500	3,951	3,554	3,785					
61,500	61,550	3,817	3,420	3,651	63,500	63,550	3,954	3,557	3,788					
61,550	61,600	3,821	3,424	3,655	63,550	63,600	3,958	3,561	3,792					
61,600	61,650	3,824	3,427	3,658	63,600	63,650	3,961	3,564	3,795					
61,650	61,700	3,828	3,431	3,662	63,650	63,700	3,965	3,568	3,799					
61,700	61,750	3,831	3,434	3,665	63,700	63,750	3,968	3,571	3,802					
61,750	61,800	3,835	3,438	3,669	63,750	63,800	3,972	3,575	3,806					
61,800	61,850	3,838	3,441	3,672	63,800	63,850	3,975	3,578	3,809					
61,850	61,900	3,841	3,444	3,675	63,850	63,900	3,978	3,581	3,812					
61,900	61,950	3,845	3,448	3,679	63,900	63,950	3,982	3,585	3,816					
61,950	62,000	3,848	3,451	3,682	63,950	64,000	3,985	3,588	3,819					



If the amount on Form IT-150, line 21, or Form IT-201, line 33, is more than \$100,000, see page 54.

* This column must also be used by a qualifying widow(er)

Tax computation — New York AGI of more than \$100,000:

New York State tax — Find your New York State tax by using *Tax computation worksheet 1* or *2* to the right.

- If the amount on Form IT-150, line 21, or Form IT-201, line 33, is **more than \$100,000, but not more than \$150,000,** **then** you must compute your tax using **Tax computation worksheet 1** below. Do **not** use the *New York State Tax Table*.

- If the amount on Form IT-150, line 21, or Form IT-201, line 33, is **more than \$150,000,** **then** you must compute your tax using **Tax computation worksheet 2** below. Do **not** use the *New York State Tax Table*.

Tax computation worksheet 1

1. Enter your New York adjusted gross income from Form IT-150, line 21, or Form IT-201, line 33..... 1. _____
2. Enter your taxable income from Form IT-150, line 26, or Form IT-201, line 38..... 2. _____
3. Multiply line 2 by 6.85% (.0685) 3. _____
4. Enter your New York State tax on the line 2 amount from the *New York State tax rate schedule on page 55* 4.
5. Subtract line 4 from line 3 5. _____
6. Enter the excess of line 1 over \$100,000 or enter \$50,000, whichever amount is less 6. _____
7. Divide line 6 by \$50,000 and round to the fourth decimal place (*cannot exceed 1.0000*) 7. _____
8. Multiply line 5 by line 7 8.
9. **Add lines 4 and 8.**
Enter here and on Form IT-150, line 27, or Form IT-201, line 39. 9. _____

Note: For some taxpayers, the line 3 amount may be the same as the line 9 amount.

Tax computation worksheet 2

1. Enter your taxable income from Form IT-150, line 26, or Form IT-201, line 38 1. _____
2. Multiply line 1 by 6.85% (.0685).
Enter here and on Form IT-150, line 27, or Form IT-201, line 39 2. _____

New York State tax rate schedule

— Notes —

Married filing jointly and qualifying widow(er) — filing status ② and ⑤

If Form IT-150, line 26, or Form IT-201, line 38 is:		The tax is:			
over	but not over				
\$ 0	\$16,000	4%	of Form IT-150, line 26, or Form IT-201, line 38		
16,000	22,000	\$640 plus 4.5%	of the excess over \$16,000		
22,000	26,000	910 plus 5.25%	" " " "		22,000
26,000	40,000	1,120 plus 5.9%	" " " "		26,000
40,000		1,946 plus 6.85%	" " " "		40,000

Single and married filing separately — filing status ① and ③

If Form IT-150, line 26, or Form IT-201, line 38 is:		The tax is:			
over	but not over				
\$ 0	\$8,000	4%	of Form IT-150, line 26, or Form IT-201, line 38		
8,000	11,000	\$320 plus 4.5%	of the excess over \$8,000		
11,000	13,000	455 plus 5.25%	" " " "		11,000
13,000	20,000	560 plus 5.9%	" " " "		13,000
20,000		973 plus 6.85%	" " " "		20,000

Head of household — filing status ④

If Form IT-150, line 26, or Form IT-201, line 38 is:		The tax is:			
over	but not over				
\$ 0	\$11,000	4%	of Form IT-150, line 26, or Form IT-201, line 38		
11,000	15,000	\$440 plus 4.5%	of the excess over \$11,000		
15,000	17,000	620 plus 5.25%	" " " "		15,000
17,000	30,000	725 plus 5.9%	" " " "		17,000
30,000		1,492 plus 6.85%	" " " "		30,000

Based on Taxable Income — For purposes of this tax table, the taxable income column below is the amount on either line 26 of Form IT-150 or line 38 of Form IT-201.

Example: Mr. and Mrs. Jones are filing a joint return on Form IT-150. Their taxable income on line 26 is \$38,275. First, they find the 38,250 - 38,300 income line. Next, they find the column for **Married filing jointly** and read down the column. The amount shown where the income line and filing status column meet is \$1,217. This is the tax amount they must write on line 30 of Form IT-150.

If your taxable income is –		And you are –		
At least	But less than	Single or Married filing separately	Married filing jointly*	Head of a household
Your New York City tax is:				
38,200	38,250	1,283	1,216	1,265
38,250	38,300	1,285	1,217	1,267
38,300	38,350	1,287	1,219	1,269
38,350	38,400	1,288	1,221	1,271

If your taxable income is –		And you are –			If your taxable income is –		And you are –			If your taxable income is –		And you are –		
At least	But less than	Single or Married filing separately	Married filing jointly*	Head of a household	At least	But less than	Single or Married filing separately	Married filing jointly*	Head of a household	At least	But less than	Single or Married filing separately	Married filing jointly*	Head of a household
		Your New York City tax is:					Your New York City tax is:					Your New York City tax is:		
\$0	\$18	\$0	\$0	\$0	2,000		Your New York City tax is:			4,000		Your New York City tax is:		
18	25	1	1	1	2,000	2,050	59	59	59	4,000	4,050	117	117	117
25	50	1	1	1	2,050	2,100	60	60	60	4,050	4,100	118	118	118
50	100	2	2	2	2,100	2,150	62	62	62	4,100	4,150	120	120	120
100	150	4	4	4	2,150	2,200	63	63	63	4,150	4,200	121	121	121
150	200	5	5	5	2,200	2,250	65	65	65	4,200	4,250	123	123	123
200	250	7	7	7	2,250	2,300	66	66	66	4,250	4,300	124	124	124
250	300	8	8	8	2,300	2,350	68	68	68	4,300	4,350	126	126	126
300	350	9	9	9	2,350	2,400	69	69	69	4,350	4,400	127	127	127
350	400	11	11	11	2,400	2,450	70	70	70	4,400	4,450	129	129	129
400	450	12	12	12	2,450	2,500	72	72	72	4,450	4,500	130	130	130
450	500	14	14	14	2,500	2,550	73	73	73	4,500	4,550	132	132	132
500	550	15	15	15	2,550	2,600	75	75	75	4,550	4,600	133	133	133
550	600	17	17	17	2,600	2,650	76	76	76	4,600	4,650	134	134	134
600	650	18	18	18	2,650	2,700	78	78	78	4,650	4,700	136	136	136
650	700	20	20	20	2,700	2,750	79	79	79	4,700	4,750	137	137	137
700	750	21	21	21	2,750	2,800	81	81	81	4,750	4,800	139	139	139
750	800	23	23	23	2,800	2,850	82	82	82	4,800	4,850	140	140	140
800	850	24	24	24	2,850	2,900	84	84	84	4,850	4,900	142	142	142
850	900	25	25	25	2,900	2,950	85	85	85	4,900	4,950	143	143	143
900	950	27	27	27	2,950	3,000	86	86	86	4,950	5,000	145	145	145
950	1,000	28	28	28	3,000	3,050	88	88	88	5,000	5,050	146	146	146
1,000		Your New York City tax is:			3,000		Your New York City tax is:			5,000		Your New York City tax is:		
1,000	1,050	30	30	30	3,000	3,050	89	89	89	5,050	5,100	148	148	148
1,050	1,100	31	31	31	3,050	3,100	91	91	91	5,100	5,150	149	149	149
1,100	1,150	33	33	33	3,100	3,150	92	92	92	5,150	5,200	150	150	150
1,150	1,200	34	34	34	3,150	3,200	94	94	94	5,200	5,250	152	152	152
1,200	1,250	36	36	36	3,200	3,250	95	95	95	5,250	5,300	153	153	153
1,250	1,300	37	37	37	3,250	3,300	97	97	97	5,300	5,350	155	155	155
1,300	1,350	39	39	39	3,300	3,350	98	98	98	5,350	5,400	156	156	156
1,350	1,400	40	40	40	3,350	3,400	100	100	100	5,400	5,450	158	158	158
1,400	1,450	41	41	41	3,400	3,450	101	101	101	5,450	5,500	159	159	159
1,450	1,500	43	43	43	3,450	3,500	102	102	102	5,500	5,550	161	161	161
1,500	1,550	44	44	44	3,500	3,550	104	104	104	5,550	5,600	162	162	162
1,550	1,600	46	46	46	3,550	3,600	105	105	105	5,600	5,650	164	164	164
1,600	1,650	47	47	47	3,600	3,650	107	107	107	5,650	5,700	165	165	165
1,650	1,700	49	49	49	3,650	3,700	108	108	108	5,700	5,750	166	166	166
1,700	1,750	50	50	50	3,700	3,750	110	110	110	5,750	5,800	168	168	168
1,750	1,800	52	52	52	3,750	3,800	111	111	111	5,800	5,850	169	169	169
1,800	1,850	53	53	53	3,800	3,850	113	113	113	5,850	5,900	171	171	171
1,850	1,900	55	55	55	3,850	3,900	114	114	114	5,900	5,950	172	172	172
1,900	1,950	56	56	56	3,900	3,950	116	116	116	5,950	6,000	174	174	174
1,950	2,000	57	57	57	3,950	4,000								

* This column must also be used by a qualifying widow(er)

If your taxable income is –		And you are –			If your taxable income is –		And you are –			If your taxable income is –		And you are –		
At least	But less than	Single or Married filing separately	Married filing jointly*	Head of a household	At least	But less than	Single or Married filing separately	Married filing jointly*	Head of a household	At least	But less than	Single or Married filing separately	Married filing jointly*	Head of a household
6,000		Your New York City tax is:			9,000		Your New York City tax is:			12,000		Your New York City tax is:		
6,000	6,050	175	175	175	9,000	9,050	262	262	262	12,000	12,050	350	350	350
6,050	6,100	177	177	177	9,050	9,100	264	264	264	12,050	12,100	352	351	351
6,100	6,150	178	178	178	9,100	9,150	265	265	265	12,100	12,150	353	352	352
6,150	6,200	180	180	180	9,150	9,200	267	267	267	12,150	12,200	355	354	354
6,200	6,250	181	181	181	9,200	9,250	268	268	268	12,200	12,250	357	355	355
6,250	6,300	182	182	182	9,250	9,300	270	270	270	12,250	12,300	359	357	357
6,300	6,350	184	184	184	9,300	9,350	271	271	271	12,300	12,350	360	358	358
6,350	6,400	185	185	185	9,350	9,400	273	273	273	12,350	12,400	362	360	360
6,400	6,450	187	187	187	9,400	9,450	274	274	274	12,400	12,450	364	361	361
6,450	6,500	188	188	188	9,450	9,500	275	275	275	12,450	12,500	366	363	363
6,500	6,550	190	190	190	9,500	9,550	277	277	277	12,500	12,550	368	364	364
6,550	6,600	191	191	191	9,550	9,600	278	278	278	12,550	12,600	369	366	366
6,600	6,650	193	193	193	9,600	9,650	280	280	280	12,600	12,650	371	367	367
6,650	6,700	194	194	194	9,650	9,700	281	281	281	12,650	12,700	373	368	368
6,700	6,750	195	195	195	9,700	9,750	283	283	283	12,700	12,750	375	370	370
6,750	6,800	197	197	197	9,750	9,800	284	284	284	12,750	12,800	376	371	371
6,800	6,850	198	198	198	9,800	9,850	286	286	286	12,800	12,850	378	373	373
6,850	6,900	200	200	200	9,850	9,900	287	287	287	12,850	12,900	380	374	374
6,900	6,950	201	201	201	9,900	9,950	289	289	289	12,900	12,950	382	376	376
6,950	7,000	203	203	203	9,950	10,000	290	290	290	12,950	13,000	383	377	377
7,000		Your New York City tax is:			10,000		Your New York City tax is:			13,000		Your New York City tax is:		
7,000	7,050	204	204	204	10,000	10,050	291	291	291	13,000	13,050	385	379	379
7,050	7,100	206	206	206	10,050	10,100	293	293	293	13,050	13,100	387	380	380
7,100	7,150	207	207	207	10,100	10,150	294	294	294	13,100	13,150	389	382	382
7,150	7,200	209	209	209	10,150	10,200	296	296	296	13,150	13,200	391	383	383
7,200	7,250	210	210	210	10,200	10,250	297	297	297	13,200	13,250	392	384	384
7,250	7,300	211	211	211	10,250	10,300	299	299	299	13,250	13,300	394	386	386
7,300	7,350	213	213	213	10,300	10,350	300	300	300	13,300	13,350	396	387	387
7,350	7,400	214	214	214	10,350	10,400	302	302	302	13,350	13,400	398	389	389
7,400	7,450	216	216	216	10,400	10,450	303	303	303	13,400	13,450	399	390	390
7,450	7,500	217	217	217	10,450	10,500	305	305	305	13,450	13,500	401	392	392
7,500	7,550	219	219	219	10,500	10,550	306	306	306	13,500	13,550	403	393	393
7,550	7,600	220	220	220	10,550	10,600	307	307	307	13,550	13,600	405	395	395
7,600	7,650	222	222	222	10,600	10,650	309	309	309	13,600	13,650	406	396	396
7,650	7,700	223	223	223	10,650	10,700	310	310	310	13,650	13,700	408	398	398
7,700	7,750	225	225	225	10,700	10,750	312	312	312	13,700	13,750	410	399	399
7,750	7,800	226	226	226	10,750	10,800	313	313	313	13,750	13,800	412	400	400
7,800	7,850	227	227	227	10,800	10,850	315	315	315	13,800	13,850	413	402	402
7,850	7,900	229	229	229	10,850	10,900	316	316	316	13,850	13,900	415	403	403
7,900	7,950	230	230	230	10,900	10,950	318	318	318	13,900	13,950	417	405	405
7,950	8,000	232	232	232	10,950	11,000	319	319	319	13,950	14,000	419	406	406
8,000		Your New York City tax is:			11,000		Your New York City tax is:			14,000		Your New York City tax is:		
8,000	8,050	233	233	233	11,000	11,050	320	320	320	14,000	14,050	421	408	408
8,050	8,100	235	235	235	11,050	11,100	322	322	322	14,050	14,100	422	409	409
8,100	8,150	236	236	236	11,100	11,150	323	323	323	14,100	14,150	424	411	411
8,150	8,200	238	238	238	11,150	11,200	325	325	325	14,150	14,200	426	412	412
8,200	8,250	239	239	239	11,200	11,250	326	326	326	14,200	14,250	428	414	414
8,250	8,300	241	241	241	11,250	11,300	328	328	328	14,250	14,300	429	415	415
8,300	8,350	242	242	242	11,300	11,350	329	329	329	14,300	14,350	431	416	416
8,350	8,400	243	243	243	11,350	11,400	331	331	331	14,350	14,400	433	418	418
8,400	8,450	245	245	245	11,400	11,450	332	332	332	14,400	14,450	435	419	420
8,450	8,500	246	246	246	11,450	11,500	334	334	334	14,450	14,500	436	421	422
8,500	8,550	248	248	248	11,500	11,550	335	335	335	14,500	14,550	438	422	423
8,550	8,600	249	249	249	11,550	11,600	336	336	336	14,550	14,600	440	424	425
8,600	8,650	251	251	251	11,600	11,650	338	338	338	14,600	14,650	442	425	427
8,650	8,700	252	252	252	11,650	11,700	339	339	339	14,650	14,700	444	427	429
8,700	8,750	254	254	254	11,700	11,750	341	341	341	14,700	14,750	445	428	430
8,750	8,800	255	255	255	11,750	11,800	342	342	342	14,750	14,800	447	430	432
8,800	8,850	257	257	257	11,800	11,850	344	344	344	14,800	14,850	449	431	434
8,850	8,900	258	258	258	11,850	11,900	345	345	345	14,850	14,900	451	432	436
8,900	8,950	259	259	259	11,900	11,950	347	347	347	14,900	14,950	452	434	438
8,950	9,000	261	261	261	11,950	12,000	348	348	348	14,950	15,000	454	435	439

* This column must also be used by a qualifying widow(er)

2006 New York City Tax Table

If your taxable income is –		And you are –			If your taxable income is –		And you are –			If your taxable income is –		And you are –		
At least	But less than	Single or Married filing separately	Married filing jointly*	Head of a household	At least	But less than	Single or Married filing separately	Married filing jointly*	Head of a household	At least	But less than	Single or Married filing separately	Married filing jointly*	Head of a household
15,000		Your New York City tax is:			18,000		Your New York City tax is:			21,000		Your New York City tax is:		
15,000	15,050	456	437	441	18,000	18,050	562	524	547	21,000	21,050	668	611	653
15,050	15,100	458	438	443	18,050	18,100	564	525	549	21,050	21,100	670	613	655
15,100	15,150	459	440	445	18,100	18,150	565	527	551	21,100	21,150	671	614	657
15,150	15,200	461	441	446	18,150	18,200	567	528	552	21,150	21,200	673	616	658
15,200	15,250	463	443	448	18,200	18,250	569	530	554	21,200	21,250	675	617	660
15,250	15,300	465	444	450	18,250	18,300	571	531	556	21,250	21,300	677	618	662
15,300	15,350	467	445	452	18,300	18,350	573	533	558	21,300	21,350	679	620	664
15,350	15,400	468	447	453	18,350	18,400	574	534	559	21,350	21,400	680	621	665
15,400	15,450	470	448	455	18,400	18,450	576	536	561	21,400	21,450	682	623	667
15,450	15,500	472	450	457	18,450	18,500	578	537	563	21,450	21,500	684	624	669
15,500	15,550	474	451	459	18,500	18,550	580	539	565	21,500	21,550	686	626	671
15,550	15,600	475	453	461	18,550	18,600	581	540	567	21,550	21,600	687	627	673
15,600	15,650	477	454	462	18,600	18,650	583	541	568	21,600	21,650	689	629	674
15,650	15,700	479	456	464	18,650	18,700	585	543	570	21,650	21,700	691	631	676
15,700	15,750	481	457	466	18,700	18,750	587	544	572	21,700	21,750	693	632	678
15,750	15,800	482	459	468	18,750	18,800	588	546	574	21,750	21,800	694	634	680
15,800	15,850	484	460	469	18,800	18,850	590	547	575	21,800	21,850	696	636	681
15,850	15,900	486	461	471	18,850	18,900	592	549	577	21,850	21,900	698	638	683
15,900	15,950	488	463	473	18,900	18,950	594	550	579	21,900	21,950	700	639	685
15,950	16,000	489	464	475	18,950	19,000	595	552	581	21,950	22,000	702	641	687
16,000		Your New York City tax is:			19,000		Your New York City tax is:			22,000		Your New York City tax is:		
16,000	16,050	491	466	476	19,000	19,050	597	553	582	22,000	22,050	703	643	688
16,050	16,100	493	467	478	19,050	19,100	599	555	584	22,050	22,100	705	645	690
16,100	16,150	495	469	480	19,100	19,150	601	556	586	22,100	22,150	707	647	692
16,150	16,200	497	470	482	19,150	19,200	603	557	588	22,150	22,200	709	648	694
16,200	16,250	498	472	483	19,200	19,250	604	559	590	22,200	22,250	710	650	696
16,250	16,300	500	473	485	19,250	19,300	606	560	591	22,250	22,300	712	652	697
16,300	16,350	502	475	487	19,300	19,350	608	562	593	22,300	22,350	714	654	699
16,350	16,400	504	476	489	19,350	19,400	610	563	595	22,350	22,400	716	655	701
16,400	16,450	505	477	491	19,400	19,450	611	565	597	22,400	22,450	717	657	703
16,450	16,500	507	479	492	19,450	19,500	613	566	598	22,450	22,500	719	659	704
16,500	16,550	509	480	494	19,500	19,550	615	568	600	22,500	22,550	721	661	706
16,550	16,600	511	482	496	19,550	19,600	617	569	602	22,550	22,600	723	662	708
16,600	16,650	512	483	498	19,600	19,650	618	570	604	22,600	22,650	724	664	710
16,650	16,700	514	485	499	19,650	19,700	620	572	605	22,650	22,700	726	666	711
16,700	16,750	516	486	501	19,700	19,750	622	573	607	22,700	22,750	728	668	713
16,750	16,800	518	488	503	19,750	19,800	624	575	609	22,750	22,800	730	670	715
16,800	16,850	520	489	505	19,800	19,850	626	576	611	22,800	22,850	732	671	717
16,850	16,900	521	491	506	19,850	19,900	627	578	612	22,850	22,900	733	673	719
16,900	16,950	523	492	508	19,900	19,950	629	579	614	22,900	22,950	735	675	720
16,950	17,000	525	493	510	19,950	20,000	631	581	616	22,950	23,000	737	677	722
17,000		Your New York City tax is:			20,000		Your New York City tax is:			23,000		Your New York City tax is:		
17,000	17,050	527	495	512	20,000	20,050	633	582	618	23,000	23,050	739	678	724
17,050	17,100	528	496	514	20,050	20,100	634	584	620	23,050	23,100	740	680	726
17,100	17,150	530	498	515	20,100	20,150	636	585	621	23,100	23,150	742	682	727
17,150	17,200	532	499	517	20,150	20,200	638	586	623	23,150	23,200	744	684	729
17,200	17,250	534	501	519	20,200	20,250	640	588	625	23,200	23,250	746	685	731
17,250	17,300	535	502	521	20,250	20,300	641	589	627	23,250	23,300	747	687	733
17,300	17,350	537	504	522	20,300	20,350	643	591	628	23,300	23,350	749	689	734
17,350	17,400	539	505	524	20,350	20,400	645	592	630	23,350	23,400	751	691	736
17,400	17,450	541	507	526	20,400	20,450	647	594	632	23,400	23,450	753	692	738
17,450	17,500	542	508	528	20,450	20,500	649	595	634	23,450	23,500	755	694	740
17,500	17,550	544	509	529	20,500	20,550	650	597	635	23,500	23,550	756	696	741
17,550	17,600	546	511	531	20,550	20,600	652	598	637	23,550	23,600	758	698	743
17,600	17,650	548	512	533	20,600	20,650	654	600	639	23,600	23,650	760	700	745
17,650	17,700	550	514	535	20,650	20,700	656	601	641	23,650	23,700	762	701	747
17,700	17,750	551	515	537	20,700	20,750	657	602	643	23,700	23,750	763	703	749
17,750	17,800	553	517	538	20,750	20,800	659	604	644	23,750	23,800	765	705	750
17,800	17,850	555	518	540	20,800	20,850	661	605	646	23,800	23,850	767	707	752
17,850	17,900	557	520	542	20,850	20,900	663	607	648	23,850	23,900	769	708	754
17,900	17,950	558	521	544	20,900	20,950	664	608	650	23,900	23,950	770	710	756
17,950	18,000	560	523	545	20,950	21,000	666	610	651	23,950	24,000	772	712	757

* This column must also be used by a qualifying widow(er)

If your taxable income is –		And you are –			If your taxable income is –		And you are –			If your taxable income is –		And you are –		
At least	But less than	Single or Married filing separately	Married filing jointly*	Head of a household	At least	But less than	Single or Married filing separately	Married filing jointly*	Head of a household	At least	But less than	Single or Married filing separately	Married filing jointly*	Head of a household
24,000		Your New York City tax is:			27,000		Your New York City tax is:			30,000		Your New York City tax is:		
24,000	24,050	774	714	759	27,000	27,050	881	820	865	30,000	30,050	988	926	971
24,050	24,100	776	715	761	27,050	27,100	883	821	867	30,050	30,100	990	928	973
24,100	24,150	777	717	763	27,100	27,150	884	823	869	30,100	30,150	992	929	974
24,150	24,200	779	719	764	27,150	27,200	886	825	870	30,150	30,200	994	931	976
24,200	24,250	781	721	766	27,200	27,250	888	827	872	30,200	30,250	996	933	978
24,250	24,300	783	723	768	27,250	27,300	890	829	874	30,250	30,300	997	935	980
24,300	24,350	785	724	770	27,300	27,350	891	830	876	30,300	30,350	999	936	982
24,350	24,400	786	726	772	27,350	27,400	893	832	878	30,350	30,400	1,001	938	983
24,400	24,450	788	728	773	27,400	27,450	895	834	879	30,400	30,450	1,003	940	985
24,450	24,500	790	730	775	27,450	27,500	897	836	881	30,450	30,500	1,005	942	987
24,500	24,550	792	731	777	27,500	27,550	899	837	883	30,500	30,550	1,006	943	989
24,550	24,600	793	733	779	27,550	27,600	900	839	885	30,550	30,600	1,008	945	991
24,600	24,650	795	735	780	27,600	27,650	902	841	886	30,600	30,650	1,010	947	992
24,650	24,700	797	737	782	27,650	27,700	904	843	888	30,650	30,700	1,012	949	994
24,700	24,750	799	738	784	27,700	27,750	906	844	890	30,700	30,750	1,014	950	996
24,750	24,800	800	740	786	27,750	27,800	908	846	892	30,750	30,800	1,015	952	998
24,800	24,850	802	742	787	27,800	27,850	909	848	893	30,800	30,850	1,017	954	1,000
24,850	24,900	804	744	789	27,850	27,900	911	850	895	30,850	30,900	1,019	956	1,001
24,900	24,950	806	746	791	27,900	27,950	913	852	897	30,900	30,950	1,021	958	1,003
24,950	25,000	808	747	793	27,950	28,000	915	853	899	30,950	31,000	1,023	959	1,005
25,000		Your New York City tax is:			28,000		Your New York City tax is:			31,000		Your New York City tax is:		
25,000	25,050	809	749	794	28,000	28,050	917	855	901	31,000	31,050	1,024	961	1,007
25,050	25,100	811	751	796	28,050	28,100	918	857	902	31,050	31,100	1,026	963	1,009
25,100	25,150	812	753	798	28,100	28,150	920	859	904	31,100	31,150	1,028	965	1,010
25,150	25,200	814	754	800	28,150	28,200	922	860	906	31,150	31,200	1,030	966	1,012
25,200	25,250	816	756	802	28,200	28,250	924	862	908	31,200	31,250	1,032	968	1,014
25,250	25,300	818	758	803	28,250	28,300	926	864	909	31,250	31,300	1,033	970	1,016
25,300	25,350	820	760	805	28,300	28,350	927	866	911	31,300	31,350	1,035	972	1,018
25,350	25,400	821	761	807	28,350	28,400	929	867	913	31,350	31,400	1,037	973	1,019
25,400	25,450	823	763	809	28,400	28,450	931	869	915	31,400	31,450	1,039	975	1,021
25,450	25,500	825	765	810	28,450	28,500	933	871	916	31,450	31,500	1,041	977	1,023
25,500	25,550	827	767	812	28,500	28,550	935	873	918	31,500	31,550	1,042	979	1,025
25,550	25,600	829	768	814	28,550	28,600	936	874	920	31,550	31,600	1,044	981	1,027
25,600	25,650	830	770	816	28,600	28,650	938	876	922	31,600	31,650	1,046	982	1,028
25,650	25,700	832	772	817	28,650	28,700	940	878	923	31,650	31,700	1,048	984	1,030
25,700	25,750	834	774	819	28,700	28,750	942	880	925	31,700	31,750	1,049	986	1,032
25,750	25,800	836	776	821	28,750	28,800	944	882	927	31,750	31,800	1,051	988	1,034
25,800	25,850	838	777	823	28,800	28,850	945	883	929	31,800	31,850	1,053	989	1,036
25,850	25,900	839	779	825	28,850	28,900	947	885	931	31,850	31,900	1,055	991	1,037
25,900	25,950	841	781	826	28,900	28,950	949	887	932	31,900	31,950	1,057	993	1,039
25,950	26,000	843	783	828	28,950	29,000	951	889	934	31,950	32,000	1,058	995	1,041
26,000		Your New York City tax is:			29,000		Your New York City tax is:			32,000		Your New York City tax is:		
26,000	26,050	845	784	830	29,000	29,050	953	890	936	32,000	32,050	1,060	996	1,043
26,050	26,100	847	786	832	29,050	29,100	954	892	938	32,050	32,100	1,062	998	1,045
26,100	26,150	848	788	833	29,100	29,150	956	894	939	32,100	32,150	1,064	1,000	1,046
26,150	26,200	850	790	835	29,150	29,200	958	896	941	32,150	32,200	1,066	1,002	1,048
26,200	26,250	852	791	837	29,200	29,250	960	897	943	32,200	32,250	1,067	1,003	1,050
26,250	26,300	854	793	839	29,250	29,300	962	899	945	32,250	32,300	1,069	1,005	1,052
26,300	26,350	856	795	840	29,300	29,350	963	901	946	32,300	32,350	1,071	1,007	1,053
26,350	26,400	857	797	842	29,350	29,400	965	903	948	32,350	32,400	1,073	1,009	1,055
26,400	26,450	859	799	844	29,400	29,450	967	905	950	32,400	32,450	1,075	1,011	1,057
26,450	26,500	861	800	846	29,450	29,500	969	906	952	32,450	32,500	1,076	1,012	1,059
26,500	26,550	863	802	847	29,500	29,550	970	908	954	32,500	32,550	1,078	1,014	1,061
26,550	26,600	865	804	849	29,550	29,600	972	910	955	32,550	32,600	1,080	1,016	1,062
26,600	26,650	866	806	851	29,600	29,650	974	912	957	32,600	32,650	1,082	1,018	1,064
26,650	26,700	868	807	853	29,650	29,700	976	913	959	32,650	32,700	1,084	1,019	1,066
26,700	26,750	870	809	855	29,700	29,750	978	915	961	32,700	32,750	1,085	1,021	1,068
26,750	26,800	872	811	856	29,750	29,800	979	917	962	32,750	32,800	1,087	1,023	1,070
26,800	26,850	874	813	858	29,800	29,850	981	919	964	32,800	32,850	1,089	1,025	1,071
26,850	26,900	875	814	860	29,850	29,900	983	920	966	32,850	32,900	1,091	1,026	1,073
26,900	26,950	877	816	862	29,900	29,950	985	922	968	32,900	32,950	1,093	1,028	1,075
26,950	27,000	879	818	863	29,950	30,000	987	924	969	32,950	33,000	1,094	1,030	1,077

* This column must also be used by a qualifying widow(er)

2006 New York City Tax Table

If your taxable income is –		And you are –			If your taxable income is –		And you are –			If your taxable income is –		And you are –		
At least	But less than	Single or Married filing separately	Married filing jointly*	Head of a household	At least	But less than	Single or Married filing separately	Married filing jointly*	Head of a household	At least	But less than	Single or Married filing separately	Married filing jointly*	Head of a household
33,000		Your New York City tax is:			36,000		Your New York City tax is:			39,000		Your New York City tax is:		
33,000	33,050	1,096	1,032	1,079	36,000	36,050	1,204	1,138	1,186	39,000	39,050	1,312	1,244	1,294
33,050	33,100	1,098	1,034	1,080	36,050	36,100	1,206	1,140	1,188	39,050	39,100	1,313	1,246	1,296
33,100	33,150	1,100	1,035	1,082	36,100	36,150	1,207	1,141	1,190	39,100	39,150	1,315	1,247	1,298
33,150	33,200	1,102	1,037	1,084	36,150	36,200	1,209	1,143	1,192	39,150	39,200	1,317	1,249	1,299
33,200	33,250	1,103	1,039	1,086	36,200	36,250	1,211	1,145	1,194	39,200	39,250	1,319	1,251	1,301
33,250	33,300	1,105	1,041	1,088	36,250	36,300	1,213	1,147	1,195	39,250	39,300	1,321	1,253	1,303
33,300	33,350	1,107	1,042	1,089	36,300	36,350	1,215	1,148	1,197	39,300	39,350	1,322	1,254	1,305
33,350	33,400	1,109	1,044	1,091	36,350	36,400	1,216	1,150	1,199	39,350	39,400	1,324	1,256	1,307
33,400	33,450	1,111	1,046	1,093	36,400	36,450	1,218	1,152	1,201	39,400	39,450	1,326	1,258	1,308
33,450	33,500	1,112	1,048	1,095	36,450	36,500	1,220	1,154	1,203	39,450	39,500	1,328	1,260	1,310
33,500	33,550	1,114	1,049	1,097	36,500	36,550	1,222	1,155	1,204	39,500	39,550	1,330	1,261	1,312
33,550	33,600	1,116	1,051	1,098	36,550	36,600	1,224	1,157	1,206	39,550	39,600	1,331	1,263	1,314
33,600	33,650	1,118	1,053	1,100	36,600	36,650	1,225	1,159	1,208	39,600	39,650	1,333	1,265	1,316
33,650	33,700	1,120	1,055	1,102	36,650	36,700	1,227	1,161	1,210	39,650	39,700	1,335	1,267	1,317
33,700	33,750	1,121	1,056	1,104	36,700	36,750	1,229	1,163	1,211	39,700	39,750	1,337	1,269	1,319
33,750	33,800	1,123	1,058	1,106	36,750	36,800	1,231	1,164	1,213	39,750	39,800	1,339	1,270	1,321
33,800	33,850	1,125	1,060	1,107	36,800	36,850	1,233	1,166	1,215	39,800	39,850	1,340	1,272	1,323
33,850	33,900	1,127	1,062	1,109	36,850	36,900	1,234	1,168	1,217	39,850	39,900	1,342	1,274	1,325
33,900	33,950	1,128	1,064	1,111	36,900	36,950	1,236	1,170	1,219	39,900	39,950	1,344	1,276	1,326
33,950	34,000	1,130	1,065	1,113	36,950	37,000	1,238	1,171	1,220	39,950	40,000	1,346	1,277	1,328
34,000		Your New York City tax is:			37,000		Your New York City tax is:			40,000		Your New York City tax is:		
34,000	34,050	1,132	1,067	1,115	37,000	37,050	1,240	1,173	1,222	40,000	40,050	1,348	1,279	1,330
34,050	34,100	1,134	1,069	1,116	37,050	37,100	1,242	1,175	1,224	40,050	40,100	1,349	1,281	1,332
34,100	34,150	1,136	1,071	1,118	37,100	37,150	1,243	1,177	1,226	40,100	40,150	1,351	1,283	1,334
34,150	34,200	1,137	1,072	1,120	37,150	37,200	1,245	1,178	1,228	40,150	40,200	1,353	1,284	1,335
34,200	34,250	1,139	1,074	1,122	37,200	37,250	1,247	1,180	1,229	40,200	40,250	1,355	1,286	1,337
34,250	34,300	1,141	1,076	1,124	37,250	37,300	1,249	1,182	1,231	40,250	40,300	1,357	1,288	1,339
34,300	34,350	1,143	1,078	1,125	37,300	37,350	1,251	1,184	1,233	40,300	40,350	1,358	1,290	1,341
34,350	34,400	1,145	1,079	1,127	37,350	37,400	1,252	1,185	1,235	40,350	40,400	1,360	1,292	1,343
34,400	34,450	1,146	1,081	1,129	37,400	37,450	1,254	1,187	1,237	40,400	40,450	1,362	1,293	1,344
34,450	34,500	1,148	1,083	1,131	37,450	37,500	1,256	1,189	1,238	40,450	40,500	1,364	1,295	1,346
34,500	34,550	1,150	1,085	1,132	37,500	37,550	1,258	1,191	1,240	40,500	40,550	1,366	1,297	1,348
34,550	34,600	1,152	1,087	1,134	37,550	37,600	1,260	1,193	1,242	40,550	40,600	1,367	1,299	1,350
34,600	34,650	1,154	1,088	1,136	37,600	37,650	1,261	1,194	1,244	40,600	40,650	1,369	1,300	1,352
34,650	34,700	1,155	1,090	1,138	37,650	37,700	1,263	1,196	1,246	40,650	40,700	1,371	1,302	1,353
34,700	34,750	1,157	1,092	1,140	37,700	37,750	1,265	1,198	1,247	40,700	40,750	1,373	1,304	1,355
34,750	34,800	1,159	1,094	1,141	37,750	37,800	1,267	1,200	1,249	40,750	40,800	1,374	1,306	1,357
34,800	34,850	1,161	1,095	1,143	37,800	37,850	1,269	1,201	1,251	40,800	40,850	1,376	1,307	1,359
34,850	34,900	1,163	1,097	1,145	37,850	37,900	1,270	1,203	1,253	40,850	40,900	1,378	1,309	1,361
34,900	34,950	1,164	1,099	1,147	37,900	37,950	1,272	1,205	1,255	40,900	40,950	1,380	1,311	1,362
34,950	35,000	1,166	1,101	1,149	37,950	38,000	1,274	1,207	1,256	40,950	41,000	1,382	1,313	1,364
35,000		Your New York City tax is:			38,000		Your New York City tax is:			41,000		Your New York City tax is:		
35,000	35,050	1,168	1,102	1,150	38,000	38,050	1,276	1,208	1,258	41,000	41,050	1,383	1,314	1,366
35,050	35,100	1,170	1,104	1,152	38,050	38,100	1,278	1,210	1,260	41,050	41,100	1,385	1,316	1,368
35,100	35,150	1,172	1,106	1,154	38,100	38,150	1,279	1,212	1,262	41,100	41,150	1,387	1,318	1,369
35,150	35,200	1,173	1,108	1,156	38,150	38,200	1,281	1,214	1,264	41,150	41,200	1,389	1,320	1,371
35,200	35,250	1,175	1,110	1,158	38,200	38,250	1,283	1,216	1,265	41,200	41,250	1,391	1,322	1,373
35,250	35,300	1,177	1,111	1,159	38,250	38,300	1,285	1,217	1,267	41,250	41,300	1,392	1,323	1,375
35,300	35,350	1,179	1,113	1,161	38,300	38,350	1,287	1,219	1,269	41,300	41,350	1,394	1,325	1,377
35,350	35,400	1,181	1,115	1,163	38,350	38,400	1,288	1,221	1,271	41,350	41,400	1,396	1,327	1,378
35,400	35,450	1,182	1,117	1,165	38,400	38,450	1,290	1,223	1,273	41,400	41,450	1,398	1,329	1,380
35,450	35,500	1,184	1,118	1,167	38,450	38,500	1,292	1,224	1,274	41,450	41,500	1,400	1,330	1,382
35,500	35,550	1,186	1,120	1,168	38,500	38,550	1,294	1,226	1,276	41,500	41,550	1,401	1,332	1,384
35,550	35,600	1,188	1,122	1,170	38,550	38,600	1,295	1,228	1,278	41,550	41,600	1,403	1,334	1,386
35,600	35,650	1,190	1,124	1,172	38,600	38,650	1,297	1,230	1,280	41,600	41,650	1,405	1,336	1,387
35,650	35,700	1,191	1,125	1,174	38,650	38,700	1,299	1,231	1,282	41,650	41,700	1,407	1,337	1,389
35,700	35,750	1,193	1,127	1,176	38,700	38,750	1,301	1,233	1,283	41,700	41,750	1,409	1,339	1,391
35,750	35,800	1,195	1,129	1,177	38,750	38,800	1,303	1,235	1,285	41,750	41,800	1,410	1,341	1,393
35,800	35,850	1,197	1,131	1,179	38,800	38,850	1,304	1,237	1,287	41,800	41,850	1,412	1,343	1,395
35,850	35,900	1,199	1,132	1,181	38,850	38,900	1,306	1,238	1,289	41,850	41,900	1,414	1,345	1,396
35,900	35,950	1,200	1,134	1,183	38,900	38,950	1,308	1,240	1,290	41,900	41,950	1,416	1,346	1,398
35,950	36,000	1,202	1,136	1,185	38,950	39,000	1,310	1,242	1,292	41,950	42,000	1,418	1,348	1,400

* This column must also be used by a qualifying widow(er)

If your taxable income is –		And you are –			If your taxable income is –		And you are –			If your taxable income is –		And you are –		
At least	But less than	Single or Married filing separately	Married filing jointly *	Head of a household	At least	But less than	Single or Married filing separately	Married filing jointly *	Head of a household	At least	But less than	Single or Married filing separately	Married filing jointly *	Head of a household
42,000		Your New York City tax is:			45,000		Your New York City tax is:			48,000		Your New York City tax is:		
42,000	42,050	1,419	1,350	1,402	45,000	45,050	1,527	1,456	1,510	48,000	48,050	1,635	1,564	1,617
42,050	42,100	1,421	1,352	1,404	45,050	45,100	1,529	1,458	1,511	48,050	48,100	1,637	1,565	1,619
42,100	42,150	1,423	1,353	1,405	45,100	45,150	1,531	1,459	1,513	48,100	48,150	1,638	1,567	1,621
42,150	42,200	1,425	1,355	1,407	45,150	45,200	1,532	1,461	1,515	48,150	48,200	1,640	1,569	1,623
42,200	42,250	1,427	1,357	1,409	45,200	45,250	1,534	1,463	1,517	48,200	48,250	1,642	1,571	1,624
42,250	42,300	1,428	1,359	1,411	45,250	45,300	1,536	1,465	1,519	48,250	48,300	1,644	1,573	1,626
42,300	42,350	1,430	1,360	1,413	45,300	45,350	1,538	1,467	1,520	48,300	48,350	1,646	1,574	1,628
42,350	42,400	1,432	1,362	1,414	45,350	45,400	1,540	1,468	1,522	48,350	48,400	1,647	1,576	1,630
42,400	42,450	1,434	1,364	1,416	45,400	45,450	1,541	1,470	1,524	48,400	48,450	1,649	1,578	1,632
42,450	42,500	1,436	1,366	1,418	45,450	45,500	1,543	1,472	1,526	48,450	48,500	1,651	1,580	1,633
42,500	42,550	1,437	1,367	1,420	45,500	45,550	1,545	1,474	1,528	48,500	48,550	1,653	1,582	1,635
42,550	42,600	1,439	1,369	1,422	45,550	45,600	1,547	1,476	1,529	48,550	48,600	1,655	1,583	1,637
42,600	42,650	1,441	1,371	1,423	45,600	45,650	1,549	1,477	1,531	48,600	48,650	1,656	1,585	1,639
42,650	42,700	1,443	1,373	1,425	45,650	45,700	1,550	1,479	1,533	48,650	48,700	1,658	1,587	1,641
42,700	42,750	1,445	1,375	1,427	45,700	45,750	1,552	1,481	1,535	48,700	48,750	1,660	1,589	1,642
42,750	42,800	1,446	1,376	1,429	45,750	45,800	1,554	1,483	1,536	48,750	48,800	1,662	1,591	1,644
42,800	42,850	1,448	1,378	1,431	45,800	45,850	1,556	1,485	1,538	48,800	48,850	1,664	1,592	1,646
42,850	42,900	1,450	1,380	1,432	45,850	45,900	1,558	1,486	1,540	48,850	48,900	1,665	1,594	1,648
42,900	42,950	1,452	1,382	1,434	45,900	45,950	1,559	1,488	1,542	48,900	48,950	1,667	1,596	1,650
42,950	43,000	1,453	1,383	1,436	45,950	46,000	1,561	1,490	1,544	48,950	49,000	1,669	1,598	1,651
43,000		Your New York City tax is:			46,000		Your New York City tax is:			49,000		Your New York City tax is:		
43,000	43,050	1,455	1,385	1,438	46,000	46,050	1,563	1,492	1,545	49,000	49,050	1,671	1,600	1,653
43,050	43,100	1,457	1,387	1,440	46,050	46,100	1,565	1,494	1,547	49,050	49,100	1,673	1,601	1,655
43,100	43,150	1,459	1,389	1,441	46,100	46,150	1,567	1,495	1,549	49,100	49,150	1,674	1,603	1,657
43,150	43,200	1,461	1,390	1,443	46,150	46,200	1,568	1,497	1,551	49,150	49,200	1,676	1,605	1,659
43,200	43,250	1,462	1,392	1,445	46,200	46,250	1,570	1,499	1,553	49,200	49,250	1,678	1,607	1,660
43,250	43,300	1,464	1,394	1,447	46,250	46,300	1,572	1,501	1,554	49,250	49,300	1,680	1,609	1,662
43,300	43,350	1,466	1,396	1,449	46,300	46,350	1,574	1,503	1,556	49,300	49,350	1,682	1,610	1,664
43,350	43,400	1,468	1,398	1,450	46,350	46,400	1,576	1,504	1,558	49,350	49,400	1,683	1,612	1,666
43,400	43,450	1,470	1,399	1,452	46,400	46,450	1,577	1,506	1,560	49,400	49,450	1,685	1,614	1,668
43,450	43,500	1,471	1,401	1,454	46,450	46,500	1,579	1,508	1,562	49,450	49,500	1,687	1,616	1,669
43,500	43,550	1,473	1,403	1,456	46,500	46,550	1,581	1,510	1,563	49,500	49,550	1,689	1,617	1,671
43,550	43,600	1,475	1,405	1,457	46,550	46,600	1,583	1,512	1,565	49,550	49,600	1,690	1,619	1,673
43,600	43,650	1,477	1,406	1,459	46,600	46,650	1,585	1,513	1,567	49,600	49,650	1,692	1,621	1,675
43,650	43,700	1,479	1,408	1,461	46,650	46,700	1,586	1,515	1,569	49,650	49,700	1,694	1,623	1,677
43,700	43,750	1,480	1,410	1,463	46,700	46,750	1,588	1,517	1,571	49,700	49,750	1,696	1,625	1,678
43,750	43,800	1,482	1,412	1,465	46,750	46,800	1,590	1,519	1,572	49,750	49,800	1,698	1,626	1,680
43,800	43,850	1,484	1,413	1,466	46,800	46,850	1,592	1,521	1,574	49,800	49,850	1,699	1,628	1,682
43,850	43,900	1,486	1,415	1,468	46,850	46,900	1,594	1,522	1,576	49,850	49,900	1,701	1,630	1,684
43,900	43,950	1,488	1,417	1,470	46,900	46,950	1,595	1,524	1,578	49,900	49,950	1,703	1,632	1,686
43,950	44,000	1,489	1,419	1,472	46,950	47,000	1,597	1,526	1,580	49,950	50,000	1,705	1,634	1,687
44,000		Your New York City tax is:			47,000		Your New York City tax is:			50,000		Your New York City tax is:		
44,000	44,050	1,491	1,420	1,474	47,000	47,050	1,599	1,528	1,581	50,000	50,050	1,707	1,635	1,689
44,050	44,100	1,493	1,422	1,475	47,050	47,100	1,601	1,530	1,583	50,050	50,100	1,709	1,637	1,691
44,100	44,150	1,495	1,424	1,477	47,100	47,150	1,603	1,531	1,585	50,100	50,150	1,711	1,639	1,693
44,150	44,200	1,497	1,426	1,479	47,150	47,200	1,604	1,533	1,587	50,150	50,200	1,712	1,641	1,694
44,200	44,250	1,498	1,428	1,481	47,200	47,250	1,606	1,535	1,589	50,200	50,250	1,714	1,643	1,696
44,250	44,300	1,500	1,429	1,483	47,250	47,300	1,608	1,537	1,590	50,250	50,300	1,716	1,644	1,698
44,300	44,350	1,502	1,431	1,484	47,300	47,350	1,610	1,538	1,592	50,300	50,350	1,718	1,646	1,700
44,350	44,400	1,504	1,433	1,486	47,350	47,400	1,611	1,540	1,594	50,350	50,400	1,720	1,648	1,702
44,400	44,450	1,506	1,435	1,488	47,400	47,450	1,613	1,542	1,596	50,400	50,450	1,722	1,650	1,703
44,450	44,500	1,507	1,436	1,490	47,450	47,500	1,615	1,544	1,598	50,450	50,500	1,723	1,652	1,705
44,500	44,550	1,509	1,438	1,492	47,500	47,550	1,617	1,546	1,599	50,500	50,550	1,725	1,653	1,707
44,550	44,600	1,511	1,440	1,493	47,550	47,600	1,619	1,547	1,601	50,550	50,600	1,727	1,655	1,709
44,600	44,650	1,513	1,442	1,495	47,600	47,650	1,620	1,549	1,603	50,600	50,650	1,729	1,657	1,711
44,650	44,700	1,515	1,443	1,497	47,650	47,700	1,622	1,551	1,605	50,650	50,700	1,731	1,659	1,712
44,700	44,750	1,516	1,445	1,499	47,700	47,750	1,624	1,553	1,607	50,700	50,750	1,732	1,661	1,714
44,750	44,800	1,518	1,447	1,501	47,750	47,800	1,626	1,555	1,608	50,750	50,800	1,734	1,662	1,716
44,800	44,850	1,520	1,449	1,502	47,800	47,850	1,628	1,556	1,610	50,800	50,850	1,736	1,664	1,718
44,850	44,900	1,522	1,451	1,504	47,850	47,900	1,629	1,558	1,612	50,850	50,900	1,738	1,666	1,720
44,900	44,950	1,524	1,452	1,506	47,900	47,950	1,631	1,560	1,614	50,900	50,950	1,740	1,668	1,721
44,950	45,000	1,525	1,454	1,508	47,950	48,000	1,633	1,562	1,615	50,950	51,000	1,742	1,670	1,723

* This column must also be used by a qualifying widow(er)

2006 New York City Tax Table

If your taxable income is –		And you are –			If your taxable income is –		And you are –			If your taxable income is –		And you are –		
At least	But less than	Single or Married filing separately	Married filing jointly*	Head of a household	At least	But less than	Single or Married filing separately	Married filing jointly*	Head of a household	At least	But less than	Single or Married filing separately	Married filing jointly*	Head of a household
51,000		Your New York City tax is:			54,000		Your New York City tax is:			57,000		Your New York City tax is:		
51,000	51,050	1,743	1,671	1,725	54,000	54,050	1,853	1,779	1,833	57,000	57,050	1,962	1,887	1,940
51,050	51,100	1,745	1,673	1,727	54,050	54,100	1,855	1,781	1,835	57,050	57,100	1,964	1,889	1,942
51,100	51,150	1,747	1,675	1,729	54,100	54,150	1,856	1,783	1,836	57,100	57,150	1,966	1,890	1,944
51,150	51,200	1,749	1,677	1,730	54,150	54,200	1,858	1,784	1,838	57,150	57,200	1,968	1,892	1,946
51,200	51,250	1,751	1,679	1,732	54,200	54,250	1,860	1,786	1,840	57,200	57,250	1,970	1,894	1,948
51,250	51,300	1,753	1,680	1,734	54,250	54,300	1,862	1,788	1,842	57,250	57,300	1,971	1,896	1,949
51,300	51,350	1,754	1,682	1,736	54,300	54,350	1,864	1,790	1,844	57,300	57,350	1,973	1,898	1,951
51,350	51,400	1,756	1,684	1,738	54,350	54,400	1,866	1,792	1,845	57,350	57,400	1,975	1,899	1,953
51,400	51,450	1,758	1,686	1,739	54,400	54,450	1,867	1,793	1,847	57,400	57,450	1,977	1,901	1,955
51,450	51,500	1,760	1,688	1,741	54,450	54,500	1,869	1,795	1,849	57,450	57,500	1,979	1,903	1,957
51,500	51,550	1,762	1,689	1,743	54,500	54,550	1,871	1,797	1,851	57,500	57,550	1,981	1,905	1,958
51,550	51,600	1,763	1,691	1,745	54,550	54,600	1,873	1,799	1,852	57,550	57,600	1,982	1,907	1,960
51,600	51,650	1,765	1,693	1,747	54,600	54,650	1,875	1,801	1,854	57,600	57,650	1,984	1,908	1,962
51,650	51,700	1,767	1,695	1,748	54,650	54,700	1,877	1,802	1,856	57,650	57,700	1,986	1,910	1,964
51,700	51,750	1,769	1,696	1,750	54,700	54,750	1,878	1,804	1,858	57,700	57,750	1,988	1,912	1,966
51,750	51,800	1,771	1,698	1,752	54,750	54,800	1,880	1,806	1,860	57,750	57,800	1,990	1,914	1,967
51,800	51,850	1,773	1,700	1,754	54,800	54,850	1,882	1,808	1,861	57,800	57,850	1,991	1,916	1,969
51,850	51,900	1,774	1,702	1,756	54,850	54,900	1,884	1,810	1,863	57,850	57,900	1,993	1,917	1,971
51,900	51,950	1,776	1,704	1,757	54,900	54,950	1,886	1,811	1,865	57,900	57,950	1,995	1,919	1,973
51,950	52,000	1,778	1,705	1,759	54,950	55,000	1,887	1,813	1,867	57,950	58,000	1,997	1,921	1,975
52,000		Your New York City tax is:			55,000		Your New York City tax is:			58,000		Your New York City tax is:		
52,000	52,050	1,780	1,707	1,761	55,000	55,050	1,889	1,815	1,869	58,000	58,050	1,999	1,923	1,976
52,050	52,100	1,782	1,709	1,763	55,050	55,100	1,891	1,817	1,870	58,050	58,100	2,001	1,925	1,978
52,100	52,150	1,784	1,711	1,765	55,100	55,150	1,893	1,819	1,872	58,100	58,150	2,002	1,926	1,980
52,150	52,200	1,785	1,713	1,766	55,150	55,200	1,895	1,820	1,874	58,150	58,200	2,004	1,928	1,982
52,200	52,250	1,787	1,714	1,768	55,200	55,250	1,897	1,822	1,876	58,200	58,250	2,006	1,930	1,984
52,250	52,300	1,789	1,716	1,770	55,250	55,300	1,898	1,824	1,878	58,250	58,300	2,008	1,932	1,985
52,300	52,350	1,791	1,718	1,772	55,300	55,350	1,900	1,826	1,879	58,300	58,350	2,010	1,934	1,987
52,350	52,400	1,793	1,720	1,773	55,350	55,400	1,902	1,828	1,881	58,350	58,400	2,012	1,935	1,989
52,400	52,450	1,794	1,722	1,775	55,400	55,450	1,904	1,829	1,883	58,400	58,450	2,013	1,937	1,991
52,450	52,500	1,796	1,723	1,777	55,450	55,500	1,906	1,831	1,885	58,450	58,500	2,015	1,939	1,993
52,500	52,550	1,798	1,725	1,779	55,500	55,550	1,908	1,833	1,887	58,500	58,550	2,017	1,941	1,994
52,550	52,600	1,800	1,727	1,781	55,550	55,600	1,909	1,835	1,888	58,550	58,600	2,019	1,942	1,996
52,600	52,650	1,802	1,729	1,782	55,600	55,650	1,911	1,837	1,890	58,600	58,650	2,021	1,944	1,998
52,650	52,700	1,804	1,731	1,784	55,650	55,700	1,913	1,838	1,892	58,650	58,700	2,022	1,946	2,000
52,700	52,750	1,805	1,732	1,786	55,700	55,750	1,915	1,840	1,894	58,700	58,750	2,024	1,948	2,002
52,750	52,800	1,807	1,734	1,788	55,750	55,800	1,917	1,842	1,896	58,750	58,800	2,026	1,950	2,003
52,800	52,850	1,809	1,736	1,790	55,800	55,850	1,918	1,844	1,897	58,800	58,850	2,028	1,951	2,005
52,850	52,900	1,811	1,738	1,791	55,850	55,900	1,920	1,846	1,899	58,850	58,900	2,030	1,953	2,007
52,900	52,950	1,813	1,740	1,793	55,900	55,950	1,922	1,847	1,901	58,900	58,950	2,032	1,955	2,009
52,950	53,000	1,815	1,741	1,795	55,950	56,000	1,924	1,849	1,903	58,950	59,000	2,033	1,957	2,010
53,000		Your New York City tax is:			56,000		Your New York City tax is:			59,000		Your New York City tax is:		
53,000	53,050	1,816	1,743	1,797	56,000	56,050	1,926	1,851	1,905	59,000	59,050	2,035	1,959	2,012
53,050	53,100	1,818	1,745	1,799	56,050	56,100	1,928	1,853	1,906	59,050	59,100	2,037	1,960	2,014
53,100	53,150	1,820	1,747	1,800	56,100	56,150	1,929	1,854	1,908	59,100	59,150	2,039	1,962	2,016
53,150	53,200	1,822	1,749	1,802	56,150	56,200	1,931	1,856	1,910	59,150	59,200	2,041	1,964	2,018
53,200	53,250	1,824	1,750	1,804	56,200	56,250	1,933	1,858	1,912	59,200	59,250	2,043	1,966	2,019
53,250	53,300	1,825	1,752	1,806	56,250	56,300	1,935	1,860	1,914	59,250	59,300	2,044	1,968	2,021
53,300	53,350	1,827	1,754	1,808	56,300	56,350	1,937	1,862	1,915	59,300	59,350	2,046	1,969	2,023
53,350	53,400	1,829	1,756	1,809	56,350	56,400	1,939	1,863	1,917	59,350	59,400	2,048	1,971	2,025
53,400	53,450	1,831	1,758	1,811	56,400	56,450	1,940	1,865	1,919	59,400	59,450	2,050	1,973	2,027
53,450	53,500	1,833	1,759	1,813	56,450	56,500	1,942	1,867	1,921	59,450	59,500	2,052	1,975	2,028
53,500	53,550	1,835	1,761	1,815	56,500	56,550	1,944	1,869	1,923	59,500	59,550	2,053	1,977	2,030
53,550	53,600	1,836	1,763	1,817	56,550	56,600	1,946	1,871	1,924	59,550	59,600	2,055	1,978	2,032
53,600	53,650	1,838	1,765	1,818	56,600	56,650	1,948	1,872	1,926	59,600	59,650	2,057	1,980	2,034
53,650	53,700	1,840	1,767	1,820	56,650	56,700	1,950	1,874	1,928	59,650	59,700	2,059	1,982	2,036
53,700	53,750	1,842	1,768	1,822	56,700	56,750	1,951	1,876	1,930	59,700	59,750	2,061	1,984	2,037
53,750	53,800	1,844	1,770	1,824	56,750	56,800	1,953	1,878	1,931	59,750	59,800	2,063	1,986	2,039
53,800	53,850	1,846	1,772	1,826	56,800	56,850	1,955	1,880	1,933	59,800	59,850	2,064	1,987	2,041
53,850	53,900	1,847	1,774	1,827	56,850	56,900	1,957	1,881	1,935	59,850	59,900	2,066	1,989	2,043
53,900	53,950	1,849	1,775	1,829	56,900	56,950	1,959	1,883	1,937	59,900	59,950	2,068	1,991	2,045
53,950	54,000	1,851	1,777	1,831	56,950	57,000	1,960	1,885	1,939	59,950	60,000	2,070	1,993	2,046

* This column must also be used by a qualifying widow(er)

If your taxable income is –		And you are –			If your taxable income is –		And you are –			If your taxable income is –		And you are –		
At least	But less than	Single or Married filing separately	Married filing jointly *	Head of a household	At least	But less than	Single or Married filing separately	Married filing jointly *	Head of a household	At least	But less than	Single or Married filing separately	Married filing jointly *	Head of a household
60,000		Your New York City tax is:			62,000		Your New York City tax is:			64,000		Your New York City tax is:		
60,000	60,050	2,072	1,995	2,048	62,000	62,050	2,145	2,066	2,121	64,000	64,050	2,218	2,138	2,194
60,050	60,100	2,074	1,996	2,050	62,050	62,100	2,146	2,068	2,123	64,050	64,100	2,219	2,140	2,196
60,100	60,150	2,075	1,998	2,052	62,100	62,150	2,148	2,070	2,125	64,100	64,150	2,221	2,142	2,197
60,150	60,200	2,077	2,000	2,053	62,150	62,200	2,150	2,072	2,126	64,150	64,200	2,223	2,144	2,199
60,200	60,250	2,079	2,002	2,055	62,200	62,250	2,152	2,074	2,128	64,200	64,250	2,225	2,145	2,201
60,250	60,300	2,081	2,004	2,057	62,250	62,300	2,154	2,075	2,130	64,250	64,300	2,227	2,147	2,203
60,300	60,350	2,083	2,005	2,059	62,300	62,350	2,156	2,077	2,132	64,300	64,350	2,229	2,149	2,205
60,350	60,400	2,084	2,007	2,061	62,350	62,400	2,157	2,079	2,134	64,350	64,400	2,230	2,151	2,207
60,400	60,450	2,086	2,009	2,063	62,400	62,450	2,159	2,081	2,135	64,400	64,450	2,232	2,153	2,208
60,450	60,500	2,088	2,011	2,064	62,450	62,500	2,161	2,083	2,137	64,450	64,500	2,234	2,154	2,210
60,500	60,550	2,090	2,013	2,066	62,500	62,550	2,163	2,084	2,139	64,500	64,550	2,236	2,156	2,212
60,550	60,600	2,092	2,014	2,068	62,550	62,600	2,165	2,086	2,141	64,550	64,600	2,238	2,158	2,214
60,600	60,650	2,094	2,016	2,070	62,600	62,650	2,167	2,088	2,143	64,600	64,650	2,240	2,160	2,216
60,650	60,700	2,095	2,018	2,072	62,650	62,700	2,168	2,090	2,145	64,650	64,700	2,241	2,162	2,218
60,700	60,750	2,097	2,020	2,073	62,700	62,750	2,170	2,092	2,146	64,700	64,750	2,243	2,163	2,219
60,750	60,800	2,099	2,021	2,075	62,750	62,800	2,172	2,093	2,148	64,750	64,800	2,245	2,165	2,221
60,800	60,850	2,101	2,023	2,077	62,800	62,850	2,174	2,095	2,150	64,800	64,850	2,247	2,167	2,223
60,850	60,900	2,103	2,025	2,079	62,850	62,900	2,176	2,097	2,152	64,850	64,900	2,249	2,169	2,225
60,900	60,950	2,105	2,027	2,081	62,900	62,950	2,178	2,099	2,154	64,900	64,950	2,250	2,171	2,227
60,950	61,000	2,106	2,029	2,083	62,950	63,000	2,179	2,100	2,156	64,950	65,000	2,252	2,172	2,228
61,000		Your New York City tax is:			63,000		Your New York City tax is:			<div style="border: 2px solid blue; border-radius: 50%; padding: 20px; width: fit-content; margin: auto;"> <p>\$65,000 or more — compute your New York City Tax using the New York City tax rate schedule on page 64.</p> </div>				
61,000	61,050	2,108	2,030	2,084	63,000	63,050	2,181	2,102	2,157					
61,050	61,100	2,110	2,032	2,086	63,050	63,100	2,183	2,104	2,159					
61,100	61,150	2,112	2,034	2,088	63,100	63,150	2,185	2,106	2,161					
61,150	61,200	2,114	2,036	2,090	63,150	63,200	2,187	2,108	2,163					
61,200	61,250	2,115	2,038	2,092	63,200	63,250	2,188	2,109	2,165					
61,250	61,300	2,117	2,039	2,094	63,250	63,300	2,190	2,111	2,166					
61,300	61,350	2,119	2,041	2,095	63,300	63,350	2,192	2,113	2,168					
61,350	61,400	2,121	2,043	2,097	63,350	63,400	2,194	2,115	2,170					
61,400	61,450	2,123	2,045	2,099	63,400	63,450	2,196	2,117	2,172					
61,450	61,500	2,125	2,047	2,101	63,450	63,500	2,198	2,118	2,174					
61,500	61,550	2,126	2,048	2,103	63,500	63,550	2,199	2,120	2,176					
61,550	61,600	2,128	2,050	2,104	63,550	63,600	2,201	2,122	2,177					
61,600	61,650	2,130	2,052	2,106	63,600	63,650	2,203	2,124	2,179					
61,650	61,700	2,132	2,054	2,108	63,650	63,700	2,205	2,126	2,181					
61,700	61,750	2,134	2,056	2,110	63,700	63,750	2,207	2,127	2,183					
61,750	61,800	2,136	2,057	2,112	63,750	63,800	2,209	2,129	2,185					
61,800	61,850	2,137	2,059	2,114	63,800	63,850	2,210	2,131	2,187					
61,850	61,900	2,139	2,061	2,115	63,850	63,900	2,212	2,133	2,188					
61,900	61,950	2,141	2,063	2,117	63,900	63,950	2,214	2,135	2,190					
61,950	62,000	2,143	2,065	2,119	63,950	64,000	2,216	2,136	2,192					

* This column must also be used by a qualifying widow(er)

New York City tax rate schedule

— Notes —

Married filing jointly and qualifying widow(er) — filing status ② and ⑤				
If Form IT-150, line 26, or Form IT-201, line 38, is:		The tax is:		
over	but not over			
\$ 0	\$21,600		2.907%	of Form IT-150, line 26, or Form IT-201, line 38
21,600	45,000	\$628	plus 3.534%	of the excess over \$21,600
45,000	90,000	1,455	plus 3.591%	" " " "
90,000	3,071	plus 3.648%	" " " "

Single and married filing separately — filing status ① and ③				
If Form IT-150, line 26, or Form IT-201, line 38, is:		The tax is:		
over	but not over			
\$ 0	\$12,000		2.907%	of Form IT-150, line 26, or Form IT-201, line 38
12,000	25,000	\$349	plus 3.534%	of the excess over \$12,000
25,000	50,000	808	plus 3.591%	" " " "
50,000	1,706	plus 3.648%	" " " "

Head of household — filing status ④				
If Form IT-150, line 26, or Form IT-201, line 38, is:		The tax is:		
over	but not over			
\$ 0	\$14,400		2.907%	of Form IT-150, line 26, or Form IT-201, line 38
14,400	30,000	\$419	plus 3.534%	of the excess over \$14,400
30,000	60,000	970	plus 3.591%	" " " "
60,000	2,047	plus 3.648%	" " " "



**For up-to-the-minute
information on New
York State tax matters,
including matters that
may affect your New
York State personal
income tax return, visit
our Web site at**

www.nystax.gov

Information on paying sales and use taxes on your income tax return

Line 35 of Form IT-150, or line 59 of Form IT-201

Note: Use these instructions on pages 66 through 72 only to complete either **line 35 of the short Form IT-150**, or **line 59 of the long Form IT-201**.

When do you owe New York State and local sales or use tax?

When you make a purchase of taxable property or services from a seller (vendor) located in New York State and take delivery in New York State, the vendor should collect state and local sales or use tax due and forward it to the Tax Department. However, you are responsible for paying the tax directly to the Tax Department under the following three circumstances:

Deliveries into New York State — You owe state and local sales or use tax if you:

- purchase property or a service that is delivered to you in New York State without payment of New York State and local tax to the seller, such as through the Internet, by catalog, from television shopping channels, or on an Indian reservation.

Purchases outside New York State with subsequent use in New York State — You may also owe state and local sales or use tax if you are a *resident* of New York State at the time you purchase any of the following *outside* New York State:

- property you bring into New York State for use in New York State;
- a service performed on property outside New York State, and you bring that property into New York State for use here; or
- a service (such as an information service) you bring into New York State for use here.

(You may be eligible for a credit for sales or use tax paid to another state. See *Instructions for Worksheets 1, 2, and 3*, Column D, on page 70.)

However, you are not required to pay state or local sales or use tax on any property or service that you bring into New York State which you purchased outside of the state before you became a resident of New York State.

Additional local tax — You may owe an additional **local** tax if you are a resident of a locality (county or city) at the time of purchase and you:

- bring property into that locality which you purchased in another locality in New York State that has a lower tax rate;
- bring property into that locality on which you had a taxable service performed in another locality in New York State that has a lower tax rate; or
- bring a service (such as an information service) into that locality which you purchased in another locality in New York State that has a lower tax rate.

However, you are not required to pay any additional local tax on any property or service that you bring into a locality in New York State that you purchased outside that locality before you became a resident of that locality.

Note: For purposes of these sales and use tax instructions, the word *tax* will be used to refer to either the sales tax or the use tax, or both.

Who is a New York State resident for sales and use tax purposes?

For sales and use tax purposes, the definition of *resident* includes persons who may not be considered residents for personal income tax purposes. For example, persons maintaining a permanent place of abode in New York who do not spend more than 183 days a year in the state, college students, and military personnel may all be residents for sales and use tax purposes even if they are not residents for income tax purposes. For sales and use tax purposes, an individual is a resident of the state and of any locality in which he or she maintains a permanent place of abode. A *permanent place of abode* is a dwelling place maintained by a person, or by another for that person to use, whether or not owned by such person, on other than a temporary or transient basis. The dwelling may be a home, apartment or flat; a room including a room at a hotel, motel, boarding house, or club; a room at a residence hall operated by an educational, charitable, or other institution; housing provided by the armed forces of the United States, whether the housing is located on or off a military base or reservation; or a trailer, mobile home, houseboat, or any other premises. This includes second homes. Therefore, you can be a resident of more than one locality and state for sales and use tax purposes.

An individual doing business in New York State is a resident for sales and use tax purposes of the state and of any county or city in which the individual is doing business, with respect to purchases of taxable property or services used in the business. Therefore, if an individual is engaged in business in New York State but has no permanent place of abode in New York State, the individual will owe use tax only on taxable purchases made with respect to the business operated in New York.

What tangible personal property and services are subject to sales and use taxes?

Most tangible personal property is subject to tax. Some examples are: cigarettes and other tobacco products; alcohol; candy; clothing; books; electronic equipment; furniture; collectibles (stamps, coins, etc., bought for collections); works of art; off-the-shelf computer software; and, generally, a garage sale item costing more than \$600.

Some examples of tax exempt items are: prescription and nonprescription drugs and medicines used for humans; certain medical equipment; newspapers; periodicals; most food items; U.S. and New York State flags; Indian arts and crafts when purchased on an Indian reservation; used mobile homes; and college textbooks.

Only certain services are subject to tax. Taxable services include maintaining, servicing, and repairing tangible personal property and real property (land and buildings). Other examples are auto repair, appliance service, house repairs, lawn maintenance, and information services. Some examples

of exempt services are dry cleaning, veterinary (except for grooming and boarding), legal, accounting, and medical services.

For more information on taxable and exempt goods and services, see Publication 750, *A Guide to Sales Tax in New York State*.

Reporting and paying sales and use taxes

You must report any unpaid sales or use tax owed for 2006 on your 2006 personal income tax return.

Note: Do not use Form IT-150 or Form IT-201 to report and pay sales and use taxes with respect to a business if you or the business is registered, or are required to be registered, for sales tax purposes. Report and pay sales and use taxes with respect to business purchases on the applicable sales and use tax return.

If you are requesting an extension of time to **file** your personal income tax return and you owe sales or use tax, you must pay any sales or use tax you owe at the time you request the extension. See Form IT-370 for more information.

If you receive an automatic extension of time to **pay** your New York State personal income tax (for example, you are in a foreign country), your sales or use tax is due when your New York State personal income tax is due.

You may report and pay your sales or use tax liability on your personal income tax return for:

- your personal purchases;
- purchases related to your royalty activities or rental real estate activities reported in Part I of federal Schedule E; and
- purchases related to your Schedule C, C-EZ, or F business (not otherwise eligible for exemption) unless the business is, or is required to be, registered for sales tax purposes.

If you are married and file a joint return, you may include your spouse's sales or use tax liability for:

- your spouse's purchases;
- purchases related to your spouse's royalty activities or rental real estate activities reported in Part I of federal Schedule E; and
- purchases related to your spouse's Schedule C, C-EZ, or F business (not otherwise eligible for exemption) unless the business is, or is required to be, registered for sales tax purposes.

If you are not filing an income tax return but owe sales or use tax for 2006, you must pay any unpaid sales or use tax by filing Form ST-140, *Individual Purchaser's Annual Report of Sales and Use Tax*, by April 16, 2007. However, if you or the business is registered or required to be registered for sales tax purposes, all sales and use taxes owed with respect to business purchases must be reported and paid with the periodic sales and use tax return.

At the time of registration, the New York State Department of Motor Vehicles (DMV) collects any unpaid sales or use tax on a motor vehicle, trailer, all-terrain vehicle, vessel, or snowmobile that must be registered or titled by DMV. Therefore, do not report or pay the sales or use tax on these items on your personal income tax return.

What happens if I don't pay the sales or use tax due?

Failure to pay sales or use tax may result in the imposition of penalty and interest. The Tax Department conducts both routine and special audits to promote compliance. In addition, the U.S. Customs Service provides the department with information from customs declarations filed by New York State residents returning from overseas travel. The Tax Department also obtains information on sales to New York State residents under information exchange agreements with other states.

Computing sales or use tax

If you do not owe any sales or use tax, you **must** enter **0** on the sales or use tax line of your personal income tax return.

For more information, see Publication 774, *Purchaser's Obligations to Pay Sales and Use Taxes Directly to the Tax Department, Questions and Answers*.

How to calculate and report your sales and use tax liability

Complete the *Computation of total sales or use tax due* section below, using the *Sales and use tax chart* and any of Worksheets 1, 2, and 3, beginning on page 69 that apply.

Purchases for less than \$1,000 each — You may elect to use one of two methods to compute your sales and use taxes for nonbusiness-related purchases of individual items or services costing less than \$1,000 each (excluding shipping and handling):

- the *Exact calculation method* on Worksheet 1 on page 69; or
- the *Sales and use tax chart* below.



The *Sales and use tax chart* is a simple, time-saving method to use to compute your sales or use tax on individual items or services costing less than \$1,000. However, you may not use it for business-related purchases or for royalty activity or rental real estate activity-related purchases, regardless of the amount. You must use the *Exact Calculation Method* on Worksheet 3 on page 70 to calculate your tax on these purchases.



If you do not owe sales or use tax, you must enter 0 on the *Sales or use tax* line on your return.

Computation of total sales or use tax due

- | | | | |
|---|---|----|----------------------|
| 1 | Tax due on nonbusiness-related items or services costing less than \$1,000 each, excluding shipping and handling (Enter your tax due on all nonbusiness-related purchases where the price of each item or service was under \$1,000. You may use the Exact Calculation Method by entering the amount from line 3 of Worksheet 1 on page 69. Or, you may elect to determine the amount by using the Sales and use tax chart below. Continue with lines 2 and 3.) | 1. | _____ |
| 2 | Tax due on nonbusiness-related items or services costing \$1,000 or more each (from line 1 of Worksheet 2 on page 69) | 2. | _____ |
| 3 | Tax due on Schedule C, Schedule C-EZ, or Schedule F business-related purchases, or Schedule E (Part I), royalty or rental real estate related purchases (from line 3 of Worksheet 3 on page 70) | 3. | _____ |
| 4 | Total sales or use tax due (Add lines 1, 2, and 3. Enter the total here and on line 35 of Form IT-150, or line 59 of Form IT-201.) | 4. | <input type="text"/> |

Sales and use tax chart (for line 1 computation only)

If your federal adjusted gross income (line 11 of Form IT-150, or line 18 of Form IT-201) is:

	Tax amount
up to \$15,000*	\$ 5
\$15,001 - \$30,000	\$15
\$30,001 - \$50,000	\$20
\$50,001 - \$75,000	\$26
\$75,001 - \$100,000	\$38
\$100,001 - \$150,000	\$53
\$150,001 - \$200,000	\$67
\$200,001 and greater	.0336% (.000336) of income, or \$200, whichever amount is smaller

* This may be any amount up to \$15,000, including 0 or a negative amount.

The following rule is for a **full-year** New York State income tax resident who did not maintain a permanent place of abode for sales tax purposes during the entire tax year.

If you maintained a permanent place of abode in New York State for sales and use tax purposes for only part of the year, multiply the tax amount from the chart (determined based on your total federal adjusted gross income for 2006) by the number of months you maintained the permanent place of abode in New York State and divide the result by 12. Enter that amount on line 1. In determining the number of months you maintained the abode in New York, count any period you maintained the abode for more than one-half month as a full month; do not count a period of one-half month or less.

Example (continued)

Your federal adjusted gross income for the year is \$53,400. You determine the amount of tax due as follows:

For line 1 of the Computation of total sales or use tax due, you elect to use the Sales and use tax chart and select the amount based on your federal AGI of \$53,400. Enter this amount on line 1 of the Computation of total sales or use tax due \$26.00

For line 2 of the Computation of total sales or use tax due, you use Worksheet 2 to calculate your tax liability on the computer purchase. $\$1,500 \times 8\%$ (state and local combined rate in Monroe County from Chart 1, on page 71). Enter this amount on line 2 of the Computation of total sales or use tax due 120.00

Total tax \$146.00

Example: You live in Monroe County in New York State.

Over the course of the year, you purchased several items for less than \$1,000 each (excluding shipping and handling) over the Internet and by catalog. You know that you did not pay any tax on the items purchased. You

may elect to use the Sales and use tax chart to determine the tax due on these purchases.

Also, on August 15, 2006, you received a computer that you ordered from a retailer located in Michigan for \$1,500 including the retailer's \$100 charge for shipping and handling. The Michigan retailer did not collect any New York or Michigan sales or use tax.

Worksheet 1 Exact calculation of tax due for nonbusiness-related purchases during 2006 costing less than \$1,000 each

Use this worksheet for nonbusiness-related purchases where the item or service cost less than \$1,000 each, excluding shipping and handling. However, the shipping and handling charges must be included in column A of Part 1 and Part 2 when computing your tax due. Therefore, the total purchase price may exceed \$110 in column A of Part 1 and \$1,000 in column A of Part 2 when the shipping and handling charges are included.

Part 1 — Purchases of clothing and footwear costing less than \$110, excluding shipping and handling, made on or after January 30, 2006, and before February 6, 2006, or on or after April 1, 2006, and before January 1, 2007.

Purchases of clothing and footwear and items used to make or repair exempt clothing, costing less than \$110 per item or pair (excluding shipping and handling), made on or after January 30, 2006, and before February 6, 2006, or on or after April 1, 2006, and before January 1, 2007, were exempt from the **state** portion of the tax and also from some local taxes. However, if the locality where you reside chose not to provide the clothing and footwear exemption, the **local** portion of the tax still applied. Chart 2 on page 72 of these instructions lists the appropriate rate of local tax for you to enter for your locality in column B below. If your locality provided the clothing and footwear exemption, its rate will be listed as **0**. In this case, do not complete Part 1.

List all clothing and footwear purchases under \$110 per item, excluding shipping and handling, made during the above periods if your locality imposed tax during one or both of these periods. (See Chart 2 on page 72.)

For fully taxable clothing and footwear purchases and for purchases of all other taxable items and services costing less than \$1,000 per item or service, excluding shipping and handling, you must also complete Part 2 below.

A Purchase price <i>(see instructions on page 70)</i>	B Your local rate <i>(from Chart 2, page 72; see instructions on page 70)</i>	C Tax <i>(multiply column A by column B)</i>	D Tax paid to another taxing jurisdiction, if any <i>(see instructions on page 70)</i>	E Tax due <i>(subtract column D from column C; do not enter less than zero)</i>
1 Total (add the Part 1, column E amounts; do not enter less than zero)				1.

Part 2 — All other taxable items and services — List all other taxable items and services and taxable clothing and footwear not included in Part 1 on which no New York State or local tax was collected from you at the time of purchase or on which you owe additional local tax (see *Information on paying sales and use taxes on your income tax return* on page 66).

Note: At the time of registration, the New York State Department of Motor Vehicles (DMV) collects any unpaid sales or use tax on a motor vehicle, trailer, all-terrain vehicle, vessel, or snowmobile that must be registered or titled by DMV. Therefore, do not report or pay the sales or use tax on these items on your personal income tax return.

A Purchase price <i>(see instructions on page 70)</i>	B Combined state and local rate <i>(from Chart 1, page 71; see instructions on page 70)</i>	C Tax <i>(multiply column A by column B)</i>	D Tax paid to another taxing jurisdiction, if any <i>(see instructions on page 70)</i>	E Tax due <i>(subtract column D from column C; do not enter less than zero)</i>
2 Total (add the Part 2, column E amounts; do not enter less than zero)				2.
3 Add lines 1 and 2; transfer this amount to the Computation of total sales or use tax due section, line 1, on page 68				3.

Worksheet 2 Nonbusiness-related purchases during 2006 costing \$1,000 or more each

Use this worksheet for nonbusiness-related purchases where the item or service cost \$1,000 or more each, excluding shipping and handling. If any item or service cost \$25,000 or more each, excluding shipping and handling, you must also complete Form IT-135, *Sales and Use Tax Report for Purchases of Items and Services Costing \$25,000 or More*, and attach it to your return.

Note: At the time of registration, the New York State Department of Motor Vehicles (DMV) collects any unpaid sales or use tax on a motor vehicle, trailer, all-terrain vehicle, vessel, or snowmobile that must be registered or titled by DMV. Therefore, do not report or pay the sales or use tax on these items on your personal income tax return.

A Purchase price <i>(see instructions on page 70)</i>	B Combined state and local rate <i>(from Chart 1, page 71; see instructions on page 70)</i>	C Tax <i>(multiply column A by column B)</i>	D Tax paid to another taxing jurisdiction, if any <i>(see instructions on page 70)</i>	E Tax due <i>(subtract column D from column C; do not enter less than zero)</i>
1 Total (transfer this amount to the Computation of total sales or use tax due section, line 2, on page 68)				1.

Worksheet 3 Schedule C, C-EZ, and Schedule F taxable business purchases or Schedule E (Part I) taxable royalty or rental real estate activity-related purchases during 2006.

Part 1 — Purchases of clothing and footwear costing less than \$110, excluding shipping and handling, made on or after January 30, 2006, and before February 6, 2006, or on or after April 1, 2006, and before January 1, 2007.

Purchases of clothing and footwear and items used to make or repair exempt clothing, costing less than \$110 per item or pair (excluding shipping and handling), made on or after January 30, 2006, and before February 6, 2006, or on or after April 1, 2006, and before January 1, 2007, were exempt from the **state** portion of the tax and also from some local taxes. However, if the locality where you reside chose not to provide the clothing and footwear exemption, the **local** portion of the tax still applied. Chart 2 on page 72 of these instructions lists the appropriate rate of local tax for you to enter for your locality in column B below. If your locality provided the clothing and footwear exemption, its rate will be listed as 0. In this case, do not complete Part 1.

List all clothing and footwear purchases under \$110 per item, excluding shipping and handling, made during the above periods if your locality imposed tax during one or both of these periods. (See Chart 2 on page 72.) However, the shipping and handling charges must be included in column A when computing your tax due.

A Purchase price <i>(see instructions below)</i>	B Your local rate <i>(from Chart 2, page 72; see instructions below)</i>	C Tax <i>(multiply column A by column B)</i>	D Tax paid to another taxing jurisdiction, if any <i>(see instructions below)</i>	E Tax due <i>(subtract column D from column C; do not enter less than zero)</i>
1 Total <i>(add the Part 1, column E amounts; do not enter less than zero)</i>				1.

Part 2 — All other taxable items and services — List all other taxable items and services and taxable clothing and footwear not included in Part 1 on which no New York State or local tax was collected from you at the time of purchase or on which you owe additional local tax (see *Information on paying sales and use taxes on your income tax return* on page 66). If any item or service purchased cost \$25,000 or more each, excluding shipping and handling, you must also complete Form IT-135, *Sales and Use Tax Report for Purchases of Items and Services Costing \$25,000 or More*, and attach it to your return.

Note: At the time of registration, the New York State Department of Motor Vehicles (DMV) collects any unpaid sales or use tax on a motor vehicle, trailer, all-terrain vehicle, vessel, or snowmobile that must be registered or titled by DMV. Therefore, do not report or pay the sales or use tax on these items on your personal income tax return.

A Purchase price <i>(see instructions below)</i>	B Combined state and local rate <i>(from Chart 1, page 71; see instructions below)</i>	C Tax <i>(multiply column A by column B)</i>	D Tax paid to another taxing jurisdiction, if any <i>(see instructions below)</i>	E Tax due <i>(subtract column D from column C; do not enter less than zero)</i>
2 Total <i>(add the Part 2, column E amounts; do not enter less than zero)</i>				2.
3 Add lines 1 and 2; transfer this amount to the <i>Computation of total sales or use tax due</i> section, line 3, on page 68				3.

Instructions for Worksheets 1, 2, and 3

Column A — Purchase price

The tax is generally computed on the price you paid for an item or service, **including** any shipping or handling charges made by the seller. However, if you were a resident of New York State at the time of purchase and you purchased property outside New York State which you used outside the state for more than six months before you brought it into the state, compute the tax on the lower of the cost or fair market value of the property at the time you brought it into New York State. This may result in a lower amount of tax. The same six month rule applies for purposes of computing local tax.

Column B — Rate

The tax rate to use is determined as follows:

- If the property or service is delivered to you in New York State, the tax is computed at the combined state and local rate in effect in the locality where the delivery occurs regardless of where you reside. The rate that applies is the rate in effect at the time of delivery.

- If you are a New York State resident and you purchase property or services outside New York State which you bring into New York State to your jurisdiction of residence, tax is computed at the combined state and local rate in effect where you reside. The rate that applies is the rate in effect at the time you brought the property or service into that jurisdiction.

In addition, if you use the property or service in another locality in New York State, you owe tax to that locality if you were also a resident of that locality at the time of the purchase, and its rate is higher than the rate in effect where the property was originally delivered to you in New York State or brought by you into New York State.

See Chart 1 or Chart 2 on pages 71 and 72 for a listing of rates through November 30, 2006. For rate changes effective December 1, 2006, visit our Web site or call the Tax Department. See *Need help?* on the back cover.

Column D — Tax paid to another taxing jurisdiction, if any

To determine whether the tax you paid to another state or local jurisdiction in another state qualifies for credit against New York State and local tax, see Publication 39, *A Guide to New York State Reciprocal Credits for Sales Taxes Paid to Other States*. If you bought the item or service in a locality in New York State other than where you reside, the tax you paid at the time of purchase may be claimed as a credit against the tax due in the locality where you reside. Federal excise taxes and customs duties, and taxes and fees you paid in foreign countries are not allowed as a credit against any New York State or local sales or use tax that you owe.

Chart 1

New York State Sales and Use Tax Rates by Jurisdiction

This chart and the notes below show the combined state and local tax rates for the period January 1, 2006, through and including November 30, 2006. Use these rates for your entries in the worksheets on pages 69 and 70. Changes to county and city rates that occurred during the period are noted in the footnotes below.

New York City comprises five counties. These counties are also boroughs whose names are more widely known. The counties, with borough names shown in parentheses, are Bronx (Bronx),

Kings (Brooklyn), New York (Manhattan), Queens (Queens), and Richmond (Staten Island).

Note that tax rates may change over the course of the year. The tax rates included with these instructions were effective through November 30, 2006. For information on whether the rates changed after November 30, 2006, visit our Web site at www.nystax.gov or call the Tax Department at 1 800 225-5829.

County or other locality	Tax rate %	County or other locality	Tax rate %	County or other locality	Tax rate %
New York State — only	4	Jefferson	7¾	St. Lawrence	7
Albany	8	Kings (Brooklyn) — see <i>New York City</i>		Saratoga — except	7
Allegany	8½	Lewis	7¾	Saratoga Springs (city)	7
Bronx — see <i>New York City</i>		Livingston	8	Schenectady	8
Brooklyn — see <i>New York City</i>		Madison — except	8	Schoharie	8
Broome	8	Oneida (city)	8	Schuyler	8
Cattaraugus — except	8	Manhattan — see <i>New York City</i>		Seneca	8
Olean (city)	8	Monroe	8	Staten Island — see <i>New York City</i>	
Salamanca (city)	8	Montgomery	8	Steuben — except	8
Cayuga — except	8	Nassau	8⅝	Corning (city)	8
Auburn (city)	8	New York (Manhattan) — see <i>New York City</i>		Hornell (city)	8
Chautauqua ¹	8	New York City	8⅝	Suffolk	8⅝
Chemung	8	Niagara	8	Sullivan	7½
Chenango — except	8	Oneida ⁴ — except	9	Tioga	8
Norwich (city)	8	Rome (city) ⁴	9	Tompkins — except	8
Clinton	7¾	Sherrill (city) ⁴	9	Ithaca (city)	8
Columbia	8	Utica (city) ⁴	9	Ulster	8
Cortland	8	Onondaga	8	Warren — except	7
Delaware	8	Ontario ⁵	7⅙	Glens Falls (city)	7
Dutchess	8⅙	Orange	8⅙	Washington	7
Erie ²	8¾	Orleans	8	Wayne	8
Essex	7¾	Oswego — except	8	Westchester — except	7⅓
Franklin ³	8	Fulton (city)	8	Mount Vernon (city)	8⅓
Fulton — except	8	Oswego (city)	8	New Rochelle (city)	8⅓
Gloversville (city)	8	Otsego	8	White Plains (city)	7⅙
Johnstown (city)	8	Putnam	7⅙	Yonkers (city)	8⅓
Genesee	8	Queens — see <i>New York City</i>		Wyoming	8
Greene	8	Rensselaer	8	Yates	8
Hamilton	7	Richmond (Staten Island) — see <i>New York City</i>			
Herkimer	8	Rockland	8		

1 Chautauqua County combined rate was 8¼% from January 1, 2006, through August 31, 2006.

2 Erie County combined rate was 8¼% from January 1, 2006, through January 14, 2006.

3 Franklin County combined rate was 7% from January 1, 2006, through May 31, 2006.

4 Oneida County combined rate, including the cities of Rome, Sherrill, and Utica, was 9½% from January 1, 2006, through August 31, 2006.

5 Ontario County combined rate was 7% from January 1, 2006, through August 31, 2006.

Chart 2 – Local Sales and Use Tax Rates on Clothing and Footwear

Effective January 30, 2006, through February 5, 2006, and April 1, 2006, through November 30, 2006

Local tax rates are shown below for jurisdictions that imposed tax on purchases of clothing and footwear costing less than \$110 per item, excluding shipping and handling, during the period beginning January 30, 2006, and ending February 5, 2006, or the period beginning April 1, 2006, and ending November 30, 2006. For possible rate change information after November 30, 2006, visit our Web site at www.nystax.gov or call the Tax Department at 1 800 225-5829. Changes to local rates that occurred during the two periods are noted in the footnotes below.

NYC enacted a year-round exemption effective September 1, 2005, that did not apply to the 4% NYS tax or the 3% MCTD taxes. Effective April 1, 2006, the year-round exemption applies to the 4% NYS sales and use taxes, the 3% MCTD taxes, and the 4% NYC local sales and use taxes in NYC.

Chautauqua County enacted a year-round exemption from its local tax effective March 1, 2006. The Chautauqua rate was 4% from March 1, 2006, through

March 31, 2006 (prior to the enactment of the NYS year-round exemption). The \$110 item-cost limitation did not apply to the 4¼% local exemption in Chautauqua County from March 1, 2006, to August 31, 2006.

Beginning April 1, 2006, there is a year-round exemption for the 4% New York State sales and use taxes for clothing, footwear, and items used to make or repair exempt clothing costing less than \$110 per item or pair. The exemption does not apply to locally imposed sales and use taxes unless that county or city imposing those taxes elected the exemption.

Use these rates for your entries in the worksheets on pages 69 and 70. If the rate for your locality is 0, no state or local tax is due on clothing and footwear costing less than \$110 purchased during that period.

New York City comprises five counties, which are also boroughs whose names are more widely known (see *Chart 1* on page 71).

Taxing jurisdiction	1/30-2/5 Tax rate %	4/1-11/30 Tax rate %
Albany County	0	4
Allegany County	0	4½
Broome County ¹	0	0
Cattaraugus County (outside the following)	0	4
Olean (city) ²	0	4
Salamanca (city)	0	4
Cayuga County (outside the following)	0	4
Auburn (city)	0	4
Chautauqua County	0	0
Chemung County	0	4
Chenango County (outside the following)	0	0
Norwich (city)	0	0
Clinton County	0	3¾
Columbia County	0	0
Cortland County	0	4
Delaware County	0	0
Dutchess County	0	0
Erie County	0	4¾
Essex County	0	3¾
Franklin County ³	0	4
Fulton County (outside the following)	0	4
Gloversville (city) ⁴	0	4
Johnstown (city)	0	4
Genesee County	0	4
Greene County	0	0
Hamilton County	0	0
Herkimer County	0	4
Jefferson County	0	3¾
Lewis County	3¾	3¾
Livingston County	0	4
Madison County (outside the following)	0	0
Oneida (city)	0	2
Monroe County	0	4
Montgomery County	0	4
Nassau County	4⅝	4⅝
New York City	0	0
Niagara County	0	4
Oneida County ⁵ (outside the following)	0	5
Rome (city) ⁵	0	5
Sherrill (city) ⁶	0	4
Utica (city) ⁵	1½	5
Onondaga County	0	4
Ontario County ⁷	0	3⅛
Orange County	4⅛	4⅛

Taxing jurisdiction	1/30-2/5 Tax rate %	4/1-11/30 Tax rate %
Orleans County	0	4
Oswego County (outside the following)	0	4
Fulton (city)	4	4
Oswego (city)	0	4
Otsego County	0	4
Putnam County	3⅞	3⅞
Rensselaer County	0	0
Rockland County	0	4
St. Lawrence County	0	3
Saratoga County (outside the following)	0	3
Saratoga Springs (city)	0	3
Schenectady County	0	4
Schoharie County	0	4
Schuyler County ⁸	0	0
Seneca County	0	4
Steuben County (outside the following)	0	4
Corning (city)	0	4
Hornell (city)	0	4
Suffolk County	0	4⅝
Sullivan County	0	3½
Tioga County	0	0
Tompkins County (outside the following)	0	4
Ithaca (city)	0	4
Ulster County	0	4
Warren County (outside the following)	0	3
Glens Falls (city)	0	3
Washington County	0	3
Wayne County	0	0
Westchester County (outside the following)	3⅞	3⅞
Mount Vernon (city)	4⅜	4⅜
New Rochelle (city)	4⅜	4⅜
White Plains (city)	3⅞	3⅞
Yonkers (city)	4⅜	4⅜
Wyoming County	0	4
Yates County	0	4

- 1 Broome County rate was 4% from April 1, 2006, through May 31, 2006.
- 2 City of Olean rate was 2½% from April 1, 2006, through May 31, 2006.
- 3 Franklin County rate was 3% from April 1, 2006, through May 31, 2006.
- 4 City of Gloversville rate was 2% from April 1, 2006, through August 31, 2006.
- 5 Oneida County rate (including the cities of Rome and Utica) was 5½% from April 1, 2006, through August 31, 2006.
- 6 City of Sherrill rate was 4½% from April 1, 2006, through August 31, 2006.
- 7 Ontario County rate was 3% from April 1, 2006, through August 31, 2006.
- 8 Schuyler County rate was 4% from April 1, 2006, through May 31, 2006.



**For up-to-the-minute
information on New
York State tax matters,
including matters that
may affect your New
York State personal
income tax return, visit
our Web site at**

www.nystax.gov

Form IT-201 (long form)

After you have completed your federal tax return ...

New York State Department of Taxation and Finance
Resident Income Tax Return (long form) IT-201
 New York State • New York City • Yonkers
 For the full year January 1, 2006, through December 31, 2006, or fiscal year beginning ... and ending ...

Step 1 Enter your social security number(s) and identifying information (page 77)

Step 2 Select your filing status and complete items B-G (page 78)

Step 3 Enter your federal income and adjustments (page 80)

Federal income and adjustments

1	Wages, salaries, tips, etc.		
2	Taxable interest income		
3	Ordinary dividends		
4	Taxable refunds, credits, or offsets of state and local income taxes		
5	Alimony received		
6	Business income or loss (attach a copy of federal Schedule C or C-EZ, Form 1040)		
7	Capital gains or losses (attach a copy of federal Form 4797)		
8	Other gains or losses (attach a copy of federal Form 4797)		
9	Taxable amount of IRA distributions		
10	Rental real estate, royalties, partnerships, S corporations, trusts, etc. (attach copy of federal Schedule E, Form 1040)		
11	Farm income or loss (attach a copy of federal Schedule F, Form 1040)		
12	Unemployment compensation		
13	Taxable amount of social security benefits (also enter on line 27 of page 2)		
14	Other income (see page 80) (Identify)		
15	Other income (see page 80) (Identify)		
16	Add lines 1 through 15		
17	Total federal adjustments to income (see page 80) (Identify)		
18	Subtract line 17 from line 16. This is your federal adjusted gross income.		

Enter your social security number(s) and identifying information (page 77)

Select your filing status and complete items B-G (page 78)

Enter your federal income and adjustments (page 80)

Calculate your New York additions and subtractions (page 81)

Enter your standard or itemized deduction and dependent exemption amounts (page 92)

Page 2

19 Enter the amount from line 18 on page 1. This is your federal adjusted gross income.

New York additions (see page 81)

20	Interest income on state and local bonds and obligations (but not those of NY State or its local governments)		
21	Public employee 414(a) retirement contributions from your wage and tax statements (see page 81)		
22	New York's 529 college savings program distributions (see page 82)		
23	Other (see page 81) (Identify)		
24	Add lines 19 through 23		

New York subtractions (see page 86)

25	Taxable refunds, credits, or offsets of state and local income taxes (from line 4 on page 1)		
26	Presses of NYS and local governments and the federal government (see page 86)		
27	Taxable amount of social security benefits (from line 14 on page 1)		
28	Interest on U.S. government bonds		
29	Pension and annuity income exclusion (see page 86)		
30	New York's 529 college savings program deduction/earnings		
31	Other (see page 81) (Identify)		
32	Add lines 25 through 31		
33	Subtract line 32 from line 24. This is your New York adjusted gross income.		

Standard deduction or itemized deduction (see page 92)

34 Enter your standard deduction (from the table below) or your itemized deduction (from the worksheet below). Mark an X in the appropriate box: Standard ... or ... Itemized

35 Subtract line 34 from line 33 (if line 34 is more than line 33, leave blank)

36 Dependent exemptions (not the same as total federal exemptions; see page 94)

37 Subtract line 36 from line 35. This is your taxable income.

New York State standard deduction table

Filing status	Standard deduction—enter on line 34 above
1 Single and you marked Item C on page 1 Yes ... \$ 3,000	
2 Single and you marked Item C on page 1 No ... 7,500	
3 Married filing joint return ... 15,000	
4 Married filing separate return ... 7,500	
5 Head of household (with qualifying person) ... 10,500	
6 Qualifying widow(er) with dependent child ... 15,000	

New York State itemized deduction worksheet

a Medical and dental expenses (from federal Schedule A, line d)

b Taxes you paid (from federal Schedule A, line g)

c Interest (you paid) (from federal Schedule A, line 14)

d Gifts to charity (from federal Schedule A, line 18)

e Casualty and theft losses (from federal Schedule A, line 19)

f Job expenses and most other miscellaneous deductions (from federal Schedule A, line 20)

g Other miscellaneous deductions (from federal Schedule A, line 21)

h Enter amount from federal Schedule A, line 29

i State, local, and foreign income taxes and

j Subtract line i from line h

k Addition adjustments

l Add lines j and k

m Itemized deduction adjustment (see page 94)

n Subtract line m from line i

o College tuition itemized deduction (see Form IT-272)

p Add lines n and o. This is your New York State itemized deduction; enter on line 34 above.

Step 4

Step 5

You must file all four pages of this original scannable return with the Tax Department.

... at a glance

Page 3

Tax computation, credits, and other taxes (see page 95)

38 Enter line amount from line 37 on page 2. This is your taxable income.

39 New York State tax on line 38 amount (see page 95 and Tax Computation on page 54)

40 New York State household credit

41 Resident credit (attach Form IT-112-R or IT-112-C or both; see page 96)

42 Other New York State nonrefundable credits (from Form IT-201-ATT, line 7; attach form)

43 Add lines 40, 41, and 42

44 Subtract line 43 from line 39 (if line 43 is more than line 39, leave blank)

45 Net other New York State taxes (from Form IT-201-ATT, line 30; attach form)

46 Add lines 44 and 45. This is the total of your New York State taxes.

New York City and Yonkers taxes, credits, and tax surcharges

47 New York City resident tax on line 38 amount (see page 96)

48 New York City household credit (from table 4, 5, or 6 on page 97)

49 Subtract line 48 from line 47 (if line 48 is more than line 47, leave blank)

50 Part-year New York City resident tax (attach Form IT-360.1)

51 Other New York City taxes (from Form IT-201-ATT, line 34; attach form)

52 Add lines 49, 50, and 51

53 NYC nonrefundable credits (from Form IT-201-ATT, line 10; attach form)

54 Subtract line 53 from line 52 (if line 53 is more than line 52, leave blank)

55 Yonkers resident income tax surcharge (see page 98)

56 Yonkers nonresident earnings tax (attach Form Y-200)

57 Part-year Yonkers resident income tax surcharge (attach Form IT-360.1)

58 Add lines 54 through 57. This is the total of your New York City and Yonkers taxes/surcharges.

59 Sales or use tax (See the instructions beginning on page 66. Do not leave line 59 blank.)

Voluntary contributions (whole dollar amounts only; see page 99)

60a Return a Gift to Wildlife

60b Missing/Exploited Children Fund

60c Breast Cancer Research Fund

60d Alzheimer's Fund

60e Olympic Fund (52 or 54; see page 99)

60f Prostate Cancer Research Fund

60g WTC Memorial Fund

60 Add lines 60a through 60g. This is your total voluntary contributions.

61 Add lines 46, 58, 59, and 60. This is your total New York State, New York City, and Yonkers taxes, sales or use tax, and voluntary contributions.

Step 6 Compute your taxes (page 95)

Step 7 Add voluntary contributions (page 99)

Taxpayer Information	Step 1	77
Filing status	Step 2	78
Federal income and adjustments	Step 3	80
NYS additions and subtractions	Step 4	81
Standard deduction and exemptions	Step 5	92
Tax computation	Step 6	95
Voluntary contributions	Step 7	99
Payments and credits	Step 8	100
Refund or amount you owe	Step 9	103
Sign and date your return	Step 10	107
Finish your return	Step 11	108

Step 8 Enter payments and credits (page 100)

Step 9 Calculate refund or amount you owe (page 103)

Step 10 Sign and date your return (page 107)

Step 11 Finish your return (page 108)

Page 4

62 Enter the amount from line 61 on page 3. This is your total New York State, New York City, and Yonkers taxes, sales or use tax, and voluntary contributions.

Payments and refundable credits (see page 100)

63 Empire State child credit (attach new Form IT-213)

64 NY State child and dependent care credit (attach Form IT-216)

65 NY State earned income credit (EIC) (attach Form IT-209)

66 NY State noncustodial parent EIC (attach new Form IT-209)

67 Real property tax credit (attach Form IT-214)

68 College tuition credit (attach Form IT-222)

69 NY City school tax credit (also complete if on page 1; see page 101)

70 NY City earned income credit (attach Form IT-215 or IT-220)

71 Other refundable credits (from Form IT-201-ATT, line 18; attach form)

72 Total New York State tax withheld

73 Total Yonkers tax withheld

74 Total estimated tax payments / Amount paid with Form IT-370

75 Total estimated tax payments / Amount paid with Form IT-370

76 Add lines 63 through 75. This is the total of your payments.

Your refund/amount overpaid (see page 103)

77 If line 76 is more than line 62, subtract line 62 from line 76.

78 Amount of line 77 that you want refunded to you (for Direct Deposit, see Account information on line 82 below)

79 Estimated tax only Amount of line 77 that you want applied to your 2007 estimated tax. (Do not include any amount that you claimed as a refund on line 76.)

Amount you owe (see page 104)

80 If line 76 is less than line 62, subtract line 76 from line 62. (For Payment options, see page 104, for electronic funds withdrawal, see Account information on line 82 below, or reduce the overpayment on line 77. See page 104.)

81 Estimated tax penalty (Include this amount on line 80, or reduce the overpayment on line 77. See page 104.)

Account information (see page 105)

82 Mark one box: Refund - Direct Deposit... or One - Electronic funds withdrawal effective date:

a Routing number: _____

b Account number: _____

c Type: Checking Savings

Sign your return below

Third-party designee: Do you want to allow another person to discuss this return with the Tax Dept? (line page 107) Yes No (complete the following)

Designee's name: _____ Designee's phone number: _____

Personal identification number (PIN): _____

Preparer's signature: _____ Date: _____

Preparer's SSN or PTIN: _____ Employee identification number: _____

Form's name (to your employer): _____ Mark as if self-employed:

Address: _____

Your signature: _____

Your occupation: _____

Spouse's signature (if joint return): _____

Spouse's occupation (if return): _____

Date: _____

Mail your completed return and any attachments to: STATE PROCESSING CENTER, PO BOX 61000, ALBANY NY 12261-0001

You must file all four pages of this original scannable return with the Tax Department.



**For up-to-the-minute
information on New
York State tax matters,
including matters that
may affect your New
York State personal
income tax return, visit
our Web site at**

www.nystax.gov

Step 1 — Completing the taxpayer information section

The diagram shows Form IT-201, Resident Income Tax Return (long form) for New York State • New York City • Yonkers, for the year 2006. The form is divided into sections labeled Part A through Part F:

- Part A:** Name and address (top left section).
- Part B:** Permanent home address (bottom left section).
- Part C:** Social security numbers (top right section).
- Part D:** New York State county of residence (middle right section).
- Part E:** School district name and code (bottom right section).
- Part F:** Decedent information (bottom right section).

Part A Name and address

If you received a tax packet by mail, your peel-off name-and-address label is under the flap on the inside front cover. **After** you complete your return, place the label in the box at the top of your return.

Check the label for accuracy. If the label is correct, go to Part B.

If any information is wrong, cross it out and make the corrections directly on the label. Space is limited so if your name contains more than 36 characters, and it is correct except for missing final characters, do not make a correction.

If you do not have a label, write the following in the spaces provided:

- Name: First name, middle initial, and last name for you, and, if you are filing a joint return, your spouse.
- Mailing address: PO box or street address, city, state, and ZIP code where you wish to receive your mail (refund and correspondence).

Foreign addresses — Enter the information in the following order: city, province or state, and then country (all in the *City, village, or post office* box). Follow the country's practice for entering the postal code. **Do not abbreviate the country name.**

Part B Permanent home address

If your mailing address is different from your permanent home address (for instance, you use a PO box), enter your permanent home address. Your permanent home address is the address of the dwelling place in New York State where you actually live, whether you or your spouse own or rent it.

- If you use a paid preparer and you use the preparer's address as your mailing address, enter the address of your permanent home in the space provided.
- If you are a permanent resident of a nursing home, enter the nursing home address.
- If you are in the armed forces and your permanent home was in New York State when you entered the military, enter your New York permanent home address regardless of where you are stationed.
- If you are married and maintain separate New York State residences and are filing separate New York State returns, enter as your permanent home address the address of your own residence.
- If you moved after December 31, 2006, enter your permanent home address as of December 31, 2006, **not** your current home address. Enter your new home

address in the mailing address area if you want your refund and other correspondence sent there.

Part C Social security numbers

You must enter your social security number(s) whether or not you are using the peel-off label. Be sure your social security numbers are in the same order as your names.

Part D New York State county of residence

If this information appears correctly on your label, go to Part E.

If you do not have a label, or the information is incorrect, enter the county in New York State where you lived on December 31, 2006. If you live in New York City, use one of the following county names:

If you live in	use county
Bronx	Bronx
Brooklyn	Kings
Manhattan	New York
Queens	Queens
Staten Island	Richmond

Part E School district name and code

If you do not have a label or your school district code number is missing or incorrect:

- **Enter the correct code number and the name of your school district.** This is the district where you were a resident on December 31, 2006. School districts and code numbers are on pages 42 through 45. If you do not know the name of your school district, contact your nearest public school.
- **You must enter your school district name and code number** even if you were absent from the school district temporarily, if the school your children attended was not in your school district, or if you had no children attending school. **Incorrect district names and code numbers may affect school aid.**

Part F Decedent information

If the taxpayer whose name is listed **first** on the return died after December 31, 2005, enter the date of death in the boxes labeled *Taxpayer's date of death*, in month, day, and last two digits of year order. If the taxpayer whose name is listed **second** died after December 31, 2005, enter the date of death in the boxes labeled *Spouse's date of death*. See *Deceased taxpayers* on page 39.

Step 2 Filing status and items B through G

Step 2 IT-201

(A) Filing status — Staple check or money order here. **mark an X in one box:**

① Single

② Married filing joint return
(enter spouse's social security number above)

③ Married filing separate return
(enter spouse's social security number above)

④ Head of household (with qualifying person)

⑤ Qualifying widow(er) with dependent child

(B) Did you itemize your deductions on your 2006 federal income tax return? Yes No

(C) Can you be claimed as a dependent on another taxpayer's federal return? Yes No

(D) If you do not need a NYS income tax forms packet mailed to you next year, mark an X in the box (see page 78).

(E) Did you or your spouse maintain living quarters in NYC during 2006 (see page 78)? Yes No

(F) NYC residents and NYC part-year residents only (see page 79):

(1) Number of months you lived in NY City in 2006

(2) Number of months your spouse lived in NY City in 2006...

(G) Enter your 2-digit special condition number if applicable (see page 79)

If applicable, also enter your second 2-digit special condition code number

Item (A)

In nearly all cases you must use the same filing status that you used on your federal return. If you did not have to file a federal return, use the filing status you would have used if you had filed.

The only exceptions to this rule apply to married individuals who file a joint federal return and:

- (1) one spouse is a New York State resident and the other is a nonresident or part-year resident. In this case, you must either: (a) file separate New York returns using filing status ③; or (b) file jointly, as if you both were New York State residents, using filing status ②.
- (2) you are unable to file a joint New York return because the address or whereabouts of your spouse is unknown, you can demonstrate that reasonable efforts have been made to locate your spouse, and good cause exists for the failure to file a joint New York return. In this case, you may file a separate New York return using filing status ③.
- (3) your spouse refuses to sign a joint New York return, reasonable efforts have been made to have your spouse sign a joint return, there exists objective evidence of alienation from your spouse such as judicial order of protection, legal separation under a decree of divorce or separate maintenance, or living apart for the twelve months immediately preceding application to file a separate return or commencement of an action for divorce or commencement of certain family court proceedings, and good cause exists for the failure to file a joint New York return. In this case, you may file a separate New York return using filing status ③.

Item (B)

If you itemized your deductions on your 2006 federal income tax return, mark an **X** in the **Yes** box. If you claimed the standard deduction on your federal return, mark an **X** in the **No** box.

Item (C)

If you can be claimed as a dependent on another taxpayer's federal return, you must mark an **X** in the **Yes** box. You must mark the **Yes** box even if the other taxpayer did not claim you as a dependent. For example, if another taxpayer was entitled to claim you as a dependent on his or her federal return, but chose not to so that you can claim the federal education credit, you must mark the **Yes** box.

Item (D)

Please help us reduce waste and taxpayer-financed paper, printing, and mailing costs. Mark an **X** in the box if you do **not** need a New York State income tax packet next year.

Most taxpayers do not need a full tax packet with forms and instructions because they can download them from our Web site at www.nystax.gov, use our fax-on-demand system, or get them at some post offices, libraries, or community centers (see *Need help?* on the back cover). Other taxpayers e-file, use tax preparation software, or go to an accountant or tax preparer to have their returns completed. **Please note that if you e-file, use software, or use a preparer, we will not send you a tax packet next year.**

If we sent you a tax packet this year and you are using an original paper return (Form IT-150 or IT-201) from your packet, we will automatically send you a tax packet next year unless you mark an **X** in the box (next year's forms will be available in January 2008). Consider your situation for next year and whether you will actually need these paper tax forms again. If not, mark an **X** in the box.

Item (E)

If you, or your spouse if married filing jointly, maintained or had use of an apartment or living quarters in New York City during any part of 2006, you must mark an **X** in the **Yes** box.

Living quarters include a house, apartment, co-op, or any other dwelling that you or your spouse maintain or pay for, or that is maintained for your primary use by another person, family member, or employer. For example, if a company leases an apartment for the principal, but not exclusive, use of the company's president or chief executive officer, that individual would be considered as maintaining living quarters in New York City even though others might use the apartment occasionally.

Note: You may be considered a New York City resident if you spend 184 days or more (a part of a day is a day for this purpose) in New York City. See the definition of *Resident, nonresident and part-year resident* on page 38. If you meet the definition, complete the New York City resident taxes and credits lines (47 through 53, and 69 and 70) on Form IT-201. See the instructions on pages 96 through 98, and 101 and 102.

Item (F)

NYC residents and NYC part-year residents only:

Enter in the applicable box the number of months you and your spouse (if filing a joint return) lived in New York City during 2006. We need this information to verify your New York City school tax credit.

All other taxpayers should leave the boxes at Item (F) blank.

Item (G)

If you qualify for one or more of the four special conditions below, enter the specified 2-digit code(s).

Code 01 Combat zone

Enter this code if you qualify for an extension of time to file and pay your tax due under the combat zone or contingency operation relief provisions. See Publication 361, *New York State Income Tax Information for Military Personnel and Veterans*.

Code 02 Combat zone, killed in action (KIA)

Enter this code if you are filing a return on behalf of a member of the armed forces who died while serving in a combat zone. See Publication 361 for information on filing a claim for tax forgiveness.

Code 03 Out of the country

Enter this code if you qualify for an automatic two-month extension of time to file your federal return because you are out of the country. For additional information, see *When to file/Important dates* on the back cover.

Code 04 Nonresident aliens

Enter this code if you are a U.S. nonresident alien for federal income tax purposes and you qualify to file your federal income tax return on or before June 15, 2007. The filing deadline for your New York return is similarly extended until June 15, 2007.

Step 3 — Federal income and adjustments

Step
3
IT-201

Federal income and adjustments

Only full-year NY State residents may file this form. For lines 1 through 18 below, enter your income items and total adjustments as they appear on your federal return (see page 80). Also see page 80 instructions for showing a loss.

	Dollars	Cents
1. Wages, salaries, tips, etc.		
2. Taxable interest income		
3. Ordinary dividends		
4. Taxable refunds, credits, or offsets of state and local income taxes (also enter on line 25 on page 2)		
5. Alimony received		
6. Business income or loss (attach a copy of federal Schedule C or C-EZ, Form 1040)		
7. Capital gain or loss (if required, attach a copy of federal Schedule D, Form 1040)		
8. Other gains or losses (attach a copy of federal Form 4797)		
9. Taxable amount of IRA distributions. If received as a beneficiary, mark an X in the box <input type="checkbox"/>		
10. Taxable amount of pensions and annuities. If received as a beneficiary, mark an X in the box <input type="checkbox"/>		
11. Rental real estate, royalties, partnerships, S corporations, trusts, etc. (attach copy of federal Schedule E, Form 1040)		
12. Farm income or loss (attach a copy of federal Schedule F, Form 1040)		
13. Unemployment compensation		
14. Taxable amount of social security benefits (also enter on line 27 on page 2)		
15. Other income (see page 80) <i>Identify: Jury duty \$438 Award \$2,000</i>	2	438
16. Add lines 1 through 15		
17. Total federal adjustments to income (see page 80) <i>Identify: IRA deduction \$438</i>	4	38
18. Subtract line 17 from line 16. This is your federal adjusted gross income	-1	000



Be sure to identify each federal adjustment and its amount.



Use a minus sign to show a loss or negative amount (entries shown are examples only).

Lines 1 through 18 Federal income tax return information

The computation of your New York State (and New York City and Yonkers) income tax is based on information you reported on your federal income tax return, including your income and federal adjustments to income. If you did not file a federal return, you must report the same income and adjustments that you would have reported for federal income tax purposes if you had filed a federal return.

Use the chart below to complete lines 1 through 18.

Be sure to enter your total other income on **line 15** and your total federal adjustments to income on **line 17**. Write each type of income and each adjustment and its amount in the shaded *Identify* areas as shown above in the examples on lines 15 and 17. If you need more room, attach a list showing each type of income and each adjustment and its amount.



Do not leave line 18 blank.

To complete Form IT-201, line:	if you filed Form 1040EZ, transfer the amount from line:	if you filed Form 1040A, transfer the amount from line:	or, if you filed Form 1040, transfer the amount from line:	and attach a copy of the following federal forms:
1	1	7	7	
2	2	8a	8a	
3		9a	9a	
4			10	
5			11	
6			12	Schedule C or C-EZ
7		10	13	Schedule D, if required
8			14	Form 4797
9		11b	15b	
10		12b	16b	
11			17	Schedule E
12			18	Schedule F
13	3	13	19	
14		14b	20b	
15			21	
16		15	22	
17		20	36	
18	4	22	38	

Step 4 — New York adjustments/New York adjusted gross income

New York additions (see page 81)

20 Interest income on state and local bonds and obligations (but not those of NY State or its local governments)												
21 Public employee 414(h) retirement contributions from your wage and tax statements (see page 82)												
22 New York's 529 college savings program distributions (see page 82)												
23 Other (see page 83) Identify: A-3 \$250; A-7 \$685												
24 Add lines 19 through 23										9	35	00

New York subtractions (see page 86)

25 Taxable refunds, credits, or offsets of state and local income taxes (from line 4 on page 1)											
26 Pensions of NYS and local governments and the federal government (see page 86)											
27 Taxable amount of social security benefits (from line 14 on page 1)											
28 Interest income on U.S. government bonds											
29 Pension and annuity income exclusion (see page 86)											
30 New York's 529 college savings program deduction/earnings											
31 Other (see page 87) Identify: S-1 \$300											
32 Add lines 25 through 31											
33 Subtract line 32 from line 24. This is your New York adjusted gross income.											

Remember to identify the addition (or subtraction) by number and include the amount. Enter the total here (entries shown are examples only).

Overview — The computation of your New York State income tax is based on your New York adjusted gross income (New York AGI), which is your federal adjusted gross income (federal AGI) modified by certain New York adjustments (New York additions and New York subtractions).

New York State taxes certain items of income not taxed by the federal government. You must add these **New York additions** to your federal AGI. Enter any of the listed additions on lines 20 through 23.

Similarly, New York State does not tax certain items of income taxed by the federal government. You must subtract these **New York subtractions** from federal AGI on lines 25 through 31.

Partners — If you have income from a partnership, include any New York adjustments that apply to that income. Obtain your share of partnership additions and subtractions from your partnership.

Beneficiaries (estates and trusts) — If you have income from an estate or trust, any New York adjustments that apply to that income, as well as any additions to or subtractions from federal itemized deductions, will be shown in your share of a single fiduciary adjustment. If the adjustment is a net addition, enter this amount on line 23; if the adjustment is a net subtraction, enter this amount on line 31. Identify this item as **FA**.

If you filed federal Form 4970, *Tax on Accumulation Distribution of Trusts*, the income you reported on line 1 of Form 4970 is not included on line 11 of Form IT-201 because the IRC considers the distribution part of federal gross income. You must therefore include on line 23 the

amount of **income you reported on Form 4970, line 1, less any interest income on state and local bonds and obligations of New York State and its local governments** (that was included on Form 4970, line 5). Be sure to identify the source of this income as **Form 4970 income**.

S Corporation shareholders — If you are a shareholder of a federal S corporation for which the election to be a New York S corporation was in effect for the tax year, include any of the following additions and subtractions that apply to your pro rata share of S corporation items of income, gain, loss, or deduction. Additions A-24, A-25, and A-26, and subtraction S-32 do not apply to you since they apply only to nonelecting S corporations. If the election to treat the corporation as a New York S corporation terminated during the tax year, you must make the additions and subtractions only to the extent they are attributable to the period for which the election to be a New York S corporation was in effect. Obtain your share of S corporation items of income, gain, loss, and deduction from the S corporation.

If you are a shareholder of an S corporation that was eligible to make the election to be a New York S corporation for the tax year but did not make the election, include additions A-24, A-25, A-26, and subtraction S-32.

If you were not eligible to make the election to treat your corporation as a New York S corporation because the corporation was not subject to Article 9-A, general business corporation franchise tax, or Article 32, banking corporation franchise tax, include any of the following additions and subtractions that apply to your pro rata share of S corporation items of income, gain, loss, or deduction. Additions A-23, A-24, A-25, and A-26, and subtractions S-31 and S-32 do not apply to you since they apply only to electing and nonelecting New York S corporations.

(continued)

If a gain or loss is recognized on your federal income tax return due to the disposition of stock or indebtedness of an S corporation that did not elect to be a New York S corporation for any tax year after December 31, 1980, make addition A-26 or subtraction S-31, whichever applies to you.

You must make the adjustments for the tax year of the S corporation that ends in your tax year.

New York additions

Line 20 Interest income on state and local bonds and obligations

Do you have interest income from state and local bonds and obligations from states other than New York State or its local governments? If **No**, go to line 21.

If **Yes**, enter any such interest income that you received or that was credited to you during 2006 that was **not** included in your federal AGI. This includes interest income on state and local bonds, interest and dividend income from tax-exempt bond mutual funds, and tax-exempt money market funds that invest in obligations of states other than New York.

If you purchased a bond between interest dates, include the amount of interest you received during the year, less the seller's accrued interest (the amount accrued from the interest date preceding your purchase to the date you purchased the bond). If you sold a bond between interest dates, include the amount of interest you received during the year plus the accrued interest amount (the amount accrued from the interest date preceding the date you sold the bond to the date you sold the bond). You should have received this information when you purchased or sold the bond.

Line 21 Public employee 414(h) retirement contribution

Are you a public employee of NYS or its local governments? If **No**, go to line 22.

If **Yes**, enter the amount of 414(h) retirement contributions, if any, shown on your wage and tax statement(s), federal Form W-2, if you are:

- a Tier 3 or Tier 4 member of the NYS and Local Retirement Systems, which include the NYS Employees' Retirement System and the NYS Police and Fire Retirement System; **or**
- a Tier 3 or Tier 4 member of the NYS Teachers' Retirement System; **or**
- an employee of the State or City University of New York who belongs to the Optional Retirement Program; **or**
- a member of any tier of the NYC Employees' Retirement System, the NYC Teachers' Retirement System, the NYC Board of Education Retirement System, the NYC Police Pension Fund or the NYC Fire Department Pension Fund; **or**
- a member of the Manhattan and Bronx Surface Transit Operating Authority (MABSTOA) Pension Plan.

Do not enter contributions to a section 401(k) deferred arrangement, section 403(b) annuity or section 457 deferred compensation plan.

Line 22 New York's 529 college savings program distributions

Did you make a withdrawal during 2006 from an account established under New York's 529 college savings program? If **No**, go to line 23.

If **Yes**, and the withdrawal was a nonqualified withdrawal, you must complete the worksheet below.

A withdrawal is nonqualified if: 1) the funds are used for purposes other than the higher education of the designated beneficiary; 2) the withdrawal is actually disbursed in cash or in-kind from the college savings program, even if the amount withdrawn is reinvested in New York's 529 college savings program within the Internal Revenue Code 60-day rollover period; or 3) on or after January 1, 2003, the funds are transferred from New York's 529 college savings program to another state's program (whether for the same beneficiary or for the benefit of another family member). However, nonqualified withdrawals **do not** include any withdrawals made in 2006 as a result of the death or disability of the designated beneficiary, regardless of how the funds are used.

Note: Transfers between accounts of family members not disbursed in cash or in-kind within New York's program are not considered distributions and are therefore not required to be added back as nonqualified withdrawals.

Include the applicable amounts from all existing accounts you own on lines 1 through 7 of the worksheet below. Do not include amounts applicable to accounts that were closed in a prior tax year. If you are filing a joint return, include the applicable amounts from all existing accounts owned by you and your spouse.

Also include on lines 1 and 2 your share of any amounts withdrawn or contributed by a partnership of which you are a partner. The partnership should provide this information to you. A partnership includes a limited liability company (LLC) that has elected to be treated as a partnership for federal income tax purposes.

Please note: Before completing the worksheet below, you must first compute your Form IT-201, **line 30, subtraction for New York's 529 college savings program** for 2006. See page 87.

Worksheet

1. Total current and prior years' nonqualified withdrawals from your account(s) 1. _____
2. Total current and prior years' contributions to your account(s) 2. _____
3. Total current year's subtraction modification (from line 1 of Worksheet for line 30 on page 87) and prior years' subtraction modifications* 3. _____
4. Subtract line 3 from line 2 4. _____
5. Total prior years' addition modifications** 5. _____
6. Add lines 4 and 5 6. _____
7. Subtract line 6 from line 1. This is your current year addition modification. Enter this amount on Form IT-201, line 22 7. _____

If line 7 is **0** (zero) or less, there is no addback.

* These amounts are included in line 28 of your 1998, 1999, and 2000 Form IT-201 (S-26 subtraction modification); on Form IT-201-I, line 29 worksheet, line 1, for tax years 2001 through 2004; in line 19 of your 2005 Form IT-150 (S-2 subtraction modification); and on Form IT-201-I, line 30 worksheet, line 1, for tax year 2005.

** These amounts are included in line 21 of your 1998, 1999 (A-3 addition modification), and 2000 (A-22 addition modification) Form IT-201; on line 21 of your 2001 through 2004 Form IT-201; in line 14 of your 2005 Form IT-150 (A-1 addition modification); and on line 22 of your 2005 Form IT-201.

Keep this worksheet with your copy of your tax return.

Line 23 Other additions

Use this line to report the following additions that are not specifically listed on Form IT-201.

Write in the applicable item number(s) (A-1 through A-26) and the amount of each addition in the white *Identify* area. Enter the total amount of these other additions in the money column.

A-1 Income from certain obligations of U.S. government agencies or instrumentalities

If, during 2006, you received or were credited with any interest or dividend income from any U.S. government authority, commission, or instrumentality that federal laws exempt from federal income tax but do not exempt from state income tax, **then** include that income. If you are uncertain whether a particular federal bond or obligation is subject to state income tax, contact the Tax Department (see *Need help?* on the back cover).

A-2 Interest expense on loans used to buy obligations exempt from NYS tax, amortized bond premium on bonds that are exempt from NYS tax and other expenses relating to the production of income exempt from NYS tax

- (a) If your federal AGI includes a deduction for interest expense used to buy bonds, obligations, or securities whose interest income is taxable for federal purposes but exempt from New York State tax, **then** include that interest expense.
- (b) If your federal AGI includes a deduction for the amortization of bond premiums on bonds whose interest income is taxable for federal purposes but exempt from NYS tax, **then** include that amortized premium.
- (c) If your federal AGI includes a deduction for expenses relating to the production of income which is taxable for federal purposes but exempt from New York State tax, **then** include that interest expense.

A-3 New York City flexible benefits program (IRC 125)

Remember to include this addition modification on line 23 if applicable.

If your wage and tax statement(s), federal Form W-2, show(s) that an amount was deducted or deferred from your salary under a flexible benefits program established by New York City or certain other New York City public employers on your behalf, **then** include this amount. Certain other New York City public employers include:

- City University of New York;
- NYC Health and Hospitals Corporation;
- NYC Transit Authority;
- NYC Housing Authority;
- NYC Off-Track Betting Corporation;
- NYC Board of Education;
- NYC School Construction Authority;
- NYC Rehabilitation Mortgage Insurance Corporation;
- Manhattan and Bronx Surface Transit Operating Authority;
and
- Staten Island Rapid Transit Authority

A-4 Health insurance and the welfare benefit fund surcharge

If you were a career pension plan member of the NYC Employees' Retirement System or the NYC Board of Education Retirement System, **and if** your wage and tax statement(s), federal Form W-2, show an amount that was deducted from your salary for health insurance and the welfare benefit fund surcharge, **then** include this amount.

A-5 Special additional mortgage recording tax deduction

If you deducted special additional mortgage recording tax in computing your federal AGI, and the special additional tax was paid before January 1, 1988, and in a prior year you were allowed a New York State personal income tax credit for that tax, **then** include the amount deducted. Do not make the addition for the tax paid to record a mortgage on or after January 1, 2004, even if you claimed a credit for that tax.

A-6 Special additional mortgage recording tax basis adjustment

If property on which you paid a special additional mortgage recording tax was sold or disposed of, and a special additional tax was paid before January 1, 1988, and in a prior year you claimed a New York State personal income tax credit for that tax, **then** include the amount, if any, of the federal basis of the property that was not adjusted to reflect the amount of the credit allowed.

A-7 Sales or dispositions of assets acquired from decedents

Note: This adjustment is not required for property acquired from decedents who died on or after February 1, 2000.

Assets of decedents can sometimes have different bases for state and federal tax purposes. This requires adjustments in the gain or loss on the sale or disposition of those assets.

If, during the tax year, there was a sale or other disposition of any assets that had been inherited or sold or disposed of directly by the estate of a decedent, **and if** the estate of the decedent was not large enough to require a federal estate tax return, **and if** the executor or administrator of that estate had valued those assets for New York State income tax purposes at less than their value for federal income tax purposes, **then** include the **difference between** (a) the gain or loss on that sale or disposition that you included in your federal AGI for the tax year and (b) the gain or loss that would have resulted if the assets had been valued the same for New York State income tax purposes as for federal income tax purposes.

A-8 Disposition of solar and wind energy systems

If in any tax year beginning on or after January 1, 1981, and ending before December 31, 1986, you took a New York State solar and wind energy credit on property, **and if** that property was sold or otherwise disposed of in 2006, **and if** a reportable gain resulted for federal income tax purposes from that sale or disposition, **and if** you had included the cost of the energy system in the federal basis of the property but did not reduce the federal basis by the state credit, **then** include the amount of the credit you had previously claimed.

(continued)

A-9 New business investment; deferral recognition

If, in any tax year beginning on or after January 1, 1982, and before 1988, you chose to subtract all or a portion of a long term capital gain from your federal AGI because you reinvested that amount in a new New York business, and you sold that reinvestment in 2006, **then** include the amount that you previously subtracted.

A-10 Qualified emerging technology investments (QETI)

If you elected to defer the gain from the sale of QETI because you reinvested in a New York qualified emerging technology company, **and if** you sold that reinvestment in 2006, **then** you must include the amount previously deferred. See subtraction S-14 on page 89.



Did you file federal Schedule(s) C-EZ, C, E, or F?

If **No**, go to line 25.

If **Yes**, see addition modifications A-11 through A-26.

A-11 Personal income taxes and unincorporated business taxes deducted in determining federal adjusted gross income

You may not deduct personal income taxes or unincorporated business taxes in computing your New York State adjusted gross income.

If you included a deduction for state, local, or foreign income taxes, including unincorporated business taxes, when computing your federal AGI, **then** you must include the amount of that deduction. For example, if you operated a business and deducted New York City unincorporated business tax on your federal Form 1040, Schedule C, as an expense of doing business, include this tax amount.

Partners — Include your distributive share of state, local, or foreign income taxes, including unincorporated business taxes, deducted in figuring net income.

S corporation shareholders — If you are a shareholder of a federal S corporation for which a New York S election was in effect, **and if** that corporation deducted taxes imposed by Article 9-A (general business corporation franchise tax), or Article 32 (banking corporation franchise tax), of the New York State Tax Law, **then** include your pro rata share of those taxes. (However, you do not need to include state or local taxes of another state, political subdivision of another state, or the District of Columbia.)

A-12 Percentage depletion

If you claimed a deduction on your federal return for percentage depletion, **then** include the amount deducted in computing your federal AGI. Also see subtraction S-21 on page 90.

A-13 Safe harbor leases (see IRC section 168(f)(8))

If, in computing your federal AGI, you took deductions attributable to a safe harbor lease (except for mass transit vehicles) made under an election provided for by IRC section 168(f)(8) as it was in effect for agreements entered into prior to January 1, 1984, **then** include those deductions. Also see A-14, S-23, and S-24.

A-14 Safe harbor leases

If your financial matters in 2006 involved a safe harbor lease (except for mass transit vehicles) made under an election provided for by section 168(f)(8) of the IRC as it was in effect for agreements entered into prior to January 1, 1984, **then** you must include the income that you would have included in your federal AGI if such an election had not been made. Also see A-13, S-23, and S-24.

A-15 Accelerated cost recovery system (ACRS) deduction

If you claimed ACRS depreciation on your federal return for:

- property placed in service during tax years 1981 through 1984 (other than 280F property); **or**
- property placed in service outside New York State for 1985 through 1993 (other than 280F property) and you elect to continue using IRC 167 depreciation (see *TSB-M-99(1)*);

then include the amount that was deducted in computing your federal AGI. You must attach Form IT-399, *New York State Depreciation Schedule*.

A-16 ACRS property; year of disposition adjustment

If you disposed of property that was depreciated for federal purposes using ACRS, and if ACRS depreciation was not allowed for state purposes (see A-15), **then** you must complete Part 2 of Form IT-399, *New York State Depreciation Schedule*, to determine the amount to include. Also see S-26 on page 90.

A-17 Farmers' school tax credit

If you claimed the farmers' school tax credit on your 2005 New York State tax return, and **if** you deducted your school taxes in computing your federal AGI on your 2005 federal return, **then** you must include the amount of the credit claimed for 2005 on this year's return. However, do not make this modification if you were required to report the amount of the credit as income on your 2006 federal return.

A-18 Sport utility vehicle expense deduction

If you claimed an IRC section 179 deduction on your federal return with respect to a sport utility vehicle that weighs more than 6,000 pounds, and you are not an eligible farmer as defined for purposes of the farmers' school tax credit (see Form IT-217-I, *Instructions for Form IT-217, Claim for Farmers' School Tax Credit*), **then** include the amount of that deduction.

A *sport utility vehicle* is any four-wheeled passenger vehicle manufactured primarily for use on public streets, roads, and highways. However, *sport utility vehicle* does not include (1) any ambulance, hearse, or combination ambulance-hearse used directly in a trade or business; (2) any vehicle used directly in the trade or business of transporting persons or property for compensation or hire; or (3) any truck, van, or motor home. A *truck* is any vehicle that has a primary load-carrying device or container attached, or is equipped with an open cargo area or covered box not readily accessible from the passenger compartment.

A-19 IRC section 168(k) property depreciation

With the exception of resurgence zone property and New York liberty zone property described in IRC section 1400L(b)(2), New York State does not follow the federal depreciation rules for IRC section 168(k) property placed in service inside or outside New York State on or after June 1, 2003. **If** you claimed a depreciation deduction for such property, **and if** no exception for resurgence zone or New York liberty zone property applies, **then** complete Part 1 of Form IT-398, *New York State Depreciation Schedule for IRC Section 168(k) Property*, to determine the amount to include. Attach Form IT-398 to your return.

A-20 Special depreciation

If you made an election for tax years beginning before 1987 for:

- special depreciation,
- research and development expenditures,
- waste treatment facility expenditures,
- air pollution control equipment expenditures, **or**
- acid deposition control equipment,

then include the amount of depreciation or expenditures relating to these items that was deducted in computing your federal AGI. Also see subtraction S-22 on page 90.

A-21 Royalty and interest payments made to a related member or members

For tax years beginning on or after January 1, 2003, New York requires certain taxpayers to add back deductions they took on their federal return for certain royalty payments for the use of intangible property, such as trademarks or patents, and interest payments they made to a related member or members. Include the amount for any such payments you deducted on your federal return. See Tax Law section 612 (r).

A-22 Environmental remediation insurance premiums

If you paid premiums for environmental remediation insurance and you claimed a deduction for such premiums and you also claimed the environmental remediation insurance credit, Form IT-613, *Claim for Environmental Remediation Insurance Credit*, **then** include the amount of the environmental remediation insurance credit allowed.



Additions A-23, A-24, A-25, A-26 apply to S corporation shareholders only. For additional information, see New York State Publication 35, *New York Tax Treatment for S Corporations and Their Shareholders*.

A-23 S corporation shareholders; reduction for taxes

If you are a shareholder of an S corporation for which a New York S corporation election was in effect for the tax year, **then** include your pro rata share of the S corporation's reductions for taxes imposed on built-in gains and reductions for taxes imposed on excess net passive income as described in IRC sections 1366(f)(2) and (3).

A-24 S corporation shareholders; pass-through loss or deduction items

If you are a shareholder of an S corporation which is a New York C corporation, **then** include any S corporation pass-through items of loss or deduction you took into account in computing your federal AGI, pursuant to IRC section 1366.

A-25 S corporation shareholders

If you did not include S corporation distributions in your federal AGI due to the application of IRC sections 1368, 1371(e), or 1379(c), **and if** these distributions were not previously subject to New York personal income tax because the corporation was a New York C corporation, **then** include these distributions.

A-26 S corporation shareholders; disposition of stock or indebtedness with increased basis

Federal law requires holders of stock or indebtedness in a federal S corporation to include undistributed taxable income in their federal AGI and take a corresponding increase in basis. New York law requires a similar increase in basis on disposition of the stock or indebtedness where the federal S corporation is or was a New York C corporation.

If you reported a federal gain or loss because of the disposition of stock or indebtedness of an S corporation, **and if** that S corporation was a New York C corporation for any tax year beginning after December 31, 1980 (in the case of a corporation taxable under Article 9-A, general business corporation tax), or December 31, 1996 (in the case of a corporation taxable under Article 32, banking corporation franchise tax), **then** include the increase in the basis of the stock or indebtedness that is due to the application of IRC sections 1376(a) (as in effect for tax years beginning before January 1, 1983) and 1367(a)(1)(A) and (B) for each tax year that a New York S election was **not** in effect.

New York subtractions

Line 26 Pensions of New York State and local governments and the federal government

Did you receive a pension or other distribution from a NYS or local government pension plan or federal government pension plan? If **No**, go to line 27.

If **Yes**, and the pension or distribution amount was included in your federal AGI, enter any pension you received, or distributions made to you from a pension plan which represents a return of contributions in a year prior to retirement, as an officer, employee, or beneficiary of an officer or employee of:

- NYS, including State and City University of New York and NYS Education Department employees who belong to the Optional Retirement Program.

Optional Retirement Program members may only subtract that portion attributable to employment with the State or City University of New York or the NYS Education Department.

- Certain public authorities, including:
 - Metropolitan Transit Authority (MTA) Police 20-Year Retirement Program;
 - Manhattan and Bronx Surface Transit Operating Authority (MABSTOA); and
 - Long Island Railroad Company.
- Local governments within the state, including:
 - NYS Teachers' Retirement System;
 - NYC Teachers' Retirement System;
 - NYC Teachers' Retirement IRC 403(b) plan; and
 - NYC variable supplemental funds (VSF), including:
 - Transit Police Officers' VSF
 - Transit Police Superior Officers' VSF
 - Housing Police Officers' VSF
 - Housing Police Superior Officers' VSF
 - Police Officers' VSF
 - Police Superior Officers' VSF
 - Firefighters' VSF
 - Fire Officers' VSF
 - Corrections Officers' VSF
 - Corrections Captain and Above VSF.
- The United States, its territories, possessions (or political subdivisions thereof), or any agency or instrumentality of the United States (including the military), or the District of Columbia.

Also include distributions received from a New York State or local pension plan or from a federal government pension plan as a **nonemployee spouse** in accordance with a court-issued qualified domestic relations order (QDRO) that meets the criteria of IRC section 414(p)(1)(A) or in accordance with a domestic relations order (DRO) issued by a New York court. For additional information, see Publication 36, *General Information for Senior Citizens and Retired Persons*.

You may **not** subtract (1) pension payments or return of contributions that were attributable to your employment by an employer other than a New York public employer, such as a private university, and any portion attributable to contributions you made to a supplemental annuity plan which was funded through a salary reduction program, or (2) periodic distributions from government (IRC section 457) deferred compensation plans. However, these payments and distributions may qualify for the pension and annuity income exclusion described in the instructions for line 29 below.

Line 28 Interest income on U.S. government bonds

Did you include interest income from U.S. government bonds or other U.S. government obligations on lines 2, 6, or 11? If **No**, go to line 29.

If **Yes**, enter the amount of interest income earned from bonds or other obligations of the U.S. government.

Dividends you received from a regulated investment company (mutual fund) that invests in obligations of the U.S. government and meet the 50% asset requirement each quarter qualify for this subtraction. The portion of such dividends that may be subtracted is based upon the portion of taxable income received by the mutual fund that is derived from federal obligations.

Contact the mutual fund for further information on meeting the 50% asset requirement and computing your allowable subtraction (if any).

If you include an amount on line 28 from more than one line on Form IT-201, attach a schedule showing the breakdown from each line.

Do not list the same interest more than once on lines 28 and 31; see the instructions for line 31, subtractions S-1 and S-3 on pages 87 and 88.

Line 29 Pension and annuity income exclusion

Did you enter an amount on line 9 or 10 that was not from a NYS or local government pension plan or federal government pension plan? If **No**, go to line 30.

If **Yes**, and you were 59½ before January 1, 2006, enter the qualifying pension and annuity income included in your 2006 federal AGI, **but not more than \$20,000**. If you became 59½ during 2006, enter only the amount received after you became 59½, **but not more than \$20,000**. If you received pension and annuity income and are married, or received pension and annuity income as a beneficiary, see below.

\$20,000 limit — You may **not** take a pension and annuity income exclusion that exceeds \$20,000, regardless of the source(s) of the income.

Qualifying pension and annuity income includes:

- periodic payments for services you performed as an employee before you retired;
- periodic and lump-sum payments from an IRA, but **not** payments derived from contributions made after you retired;
- periodic distributions from government (IRC section 457) deferred compensation plans;

- periodic distributions from an annuity contract (IRC section 403(b)) purchased by an employer for an employee and the employer is a corporation, community chest, fund, foundation, or public school;
- periodic payments from an HR-10 (Keogh) plan, but **not** payments derived from contributions made after you retired;
- lump-sum payments from an HR-10 (Keogh) plan, but only if federal Form 4972 is not used. Do **not** include that part of your payment that was derived from contributions made after you retired;
- periodic distributions of benefits from a cafeteria plan (IRC section 125) or a qualified cash or deferred profit-sharing or stock bonus plan (IRC section 401(k)), but not distributions derived from contributions made after you retired.

Qualifying pension and annuity income **does not** include distributions received as a **nonemployee spouse** in accordance with a court-issued qualified domestic relations order (QDRO) that meets the criteria of IRC section 414(p)(1)(A) or in accordance with a domestic relations order (DRO) issued by a New York court. For additional information, see Publication 36, *General Information for Senior Citizens and Retired Persons*.

Married taxpayers — If you both qualify, you and your spouse can each subtract up to \$20,000 of your own pension and annuity income. However, you cannot claim any unused part of your spouse’s exclusion.

Example: A husband and wife, both age 62, included total pension and annuity income of \$45,000 in their federal AGI on their 2006 joint federal tax return. The husband received qualifying pension and annuity payments totaling \$30,000 and the wife received qualifying payments totaling \$15,000. They are filing a joint 2006 New York State resident personal income tax return. The husband may claim the maximum pension and annuity income exclusion of \$20,000, and the wife may claim an exclusion of \$15,000, for a total pension and annuity income exclusion of \$35,000.

Beneficiaries — If you received a decedent’s pension and annuity income, you may make this subtraction if the decedent would have been entitled to it, had the decedent continued to live, regardless of your age. If the decedent would have become 59½ during 2006, enter only the amount received after the decedent would have become 59½, but not more than \$20,000.

In addition, the pension and annuity income exclusion of the decedent that you are eligible to claim as a beneficiary must first be reduced by the amount subtracted on the decedent’s New York State personal income tax return, if any. The total pension and annuity income exclusion claimed by the decedent and you cannot exceed \$20,000.

If the decedent has more than one beneficiary, the decedent’s \$20,000 pension and annuity income exclusion must be allocated among the beneficiaries in the same ratio as the distribution, so that the total exclusion attributable to the decedent does not exceed \$20,000.

Example: A taxpayer received pension and annuity income totaling \$6,000 as a beneficiary of a decedent who was 59½ before January 1, 2006. The decedent’s total pension and annuity income was \$24,000, shared equally among four beneficiaries. Each beneficiary is entitled to one-quarter of the decedent’s pension exclusion, or \$5,000 (\$20,000 divided by 4). The taxpayer also received a qualifying pension and annuity payment of \$14,000 in 2006. The

taxpayer is entitled to claim a pension and annuity income exclusion of \$19,000 (\$14,000 attributable to the taxpayer’s own pension and annuity payment, plus \$5,000 received as a beneficiary).*

* The total amount of the taxpayer’s pension and annuity income exclusion that can be applied against the taxpayer’s pension and annuity income received as a beneficiary is limited to the taxpayer’s share of the decedent’s pension and annuity income exclusion.

Disability income exclusion — If you are also claiming the disability income exclusion, the total of your pension and annuity income exclusion and disability income exclusion cannot exceed \$20,000.

Line 30 New York’s 529 college savings program deduction/earnings distributions

During 2006, did you make contributions to or a withdrawal from one or more tuition savings accounts established under New York’s 529 college savings program? If **No**, go to line 31.

If you made contributions, enter the amount up to \$5,000 (\$10,000 for married taxpayers filing a joint return) on line 1 of the worksheet below.

If you made a withdrawal and part of the withdrawal was included in your federal AGI on line 21 of federal Form 1040, **then** enter that amount on line 2 of the worksheet below.

Worksheet

1. Amount of contributions you made in 2006 to an account established under New York’s 529 college savings program* (cannot exceed \$5,000 for an individual, head of household, married taxpayers filing separately, or qualifying widow(er), or \$10,000 for married taxpayers filing a joint return)..... 1. _____
2. Amount of Qualified Tuition Program distribution reported on federal Form 1040, line 21* 2. _____
3. Add lines 1 and 2. **Enter here and on Form IT-201, line 30** 3.

* In determining the amount to enter on lines 1 and 2, also include your share of any amounts contributed or withdrawn by a partnership of which you are a member partner. The partnership should provide this information to you.

Note: Keep this worksheet for future-year computations of the line 22 worksheet (see page 82).

Line 31 Other subtractions

Use this line to report the following subtractions that are not specifically listed on Form IT-201.

Write in the applicable item number(s) (S-1 through S-32) and the amount of each subtraction in the white *Identify* area on line 31. Enter the total amount of these subtractions on line 31 in the money column.

S-1 Certain investment income from U.S. government agencies

Include any interest or dividend income on bonds or securities of any U.S. authority, commission, or instrumentality that is exempt from state income taxes under federal laws (but that you included in your federal AGI).

S-2 Certain railroad retirement income and railroad unemployment insurance benefits

Include supplemental annuity or Tier 2 benefits received under the Railroad Retirement Act of 1974, or benefits received under the Railroad Unemployment Insurance Act that are exempt from state income taxes under federal laws (but that you included in your federal AGI).

S-3 Certain investment income exempted by other New York State laws

Include any interest or dividend income from any obligations or securities authorized to be issued and exempt from state taxation under the laws of New York State. (For example, income received from bonds, mortgages, and income debenture certificates of limited dividend housing corporations organized under the Private Housing Finance Law.)

S-4 Disability income exclusion

Complete Form IT-221, *Disability Income Exclusion*, to compute your disability income exclusion if you were not yet 65 when your tax year ended, **and** you retired on disability, and you were permanently and totally disabled when you retired.

S-5 Long-term residential care deduction

If you were a resident in a continuing-care retirement community that was issued a certificate of authority by the NYS Department of Health, **then** include the portion of the fees you paid during the year that were attributable to the cost of providing long-term care benefits to you under a continuing care contract. However, do not enter more than the premium limitation shown for your age in the *Limitation* table below. If you and your spouse both qualify, you may each take the subtraction. However, you cannot claim any unused part of your spouse's subtraction.

If your age at the end of 2006 was:	Limitation	You cannot claim more than:
40 or younger.....		\$ 280
at least 41 but not older than 50		530
at least 51 but not older than 60		1,060
at least 61 but not older than 70		2,830
71 or older.....		3,530

S-6 New York State organized militia income

Include income that you received as a member of the New York State organized militia for performing active service within NYS due to either state active duty orders issued in accordance with Military Law section 6.1 or federal active duty orders, for service other than training, issued in accordance with Title 10 of the United States Code, that was included in your federal AGI. Do not include any income you receive for regular duties in the organized militia (for example, pay received for the annual two-week training program). Members of the NYS organized militia include the New York Army National Guard, the New York Air National Guard, the New York Naval Militia, and the New York Guard.

S-7 Loss from the sale or disposition of property that would have been realized if a federal estate tax return had been required

Note: This subtraction cannot be made for property acquired from decedents who died on or after February 1, 2000.

If you acquired a decedent's property and, as valued by the executor, the estate was insufficient to require a federal estate tax return, **and** if a loss on the sale would have been realized if a federal estate tax return had been required, **then** include the amount of the loss.

S-8 Accelerated death benefits received that were includable in federal adjusted gross income

Include any amount you included in your federal AGI that was received by any person as (a) an accelerated payment or payments of part or all of the death benefit or special surrender value under a life insurance policy, or (b) a viatical settlement, as a result of a terminal illness (life expectancy of 12 months or less), or of a medical condition requiring extraordinary medical treatment, regardless of life expectancy.

S-9 Contributions for Executive Mansion, natural and historical resources, not deducted elsewhere

Include contributions you made, not deducted elsewhere, (a) to preserve, improve, and promote the Executive Mansion as a New York State historical resource, or (b) to the Natural Heritage Trust to preserve and improve the natural and historical resources of NYS. **Do not** include amounts you deducted in determining federal AGI or New York itemized deductions.

S-10 Distributions made to a victim of Nazi persecution

Include amounts you included in your federal AGI from an eligible settlement fund or grantor trust as defined by section 13 of the Tax Law (because you were persecuted or targeted for persecution by the Nazi regime), or distributions received because of your status as a victim of Nazi persecution, or as a spouse or heir of the victim (successors or assignees, if payment is from an eligible settlement fund or grantor trust).

S-11 Items of income related to assets stolen from, hidden from, or otherwise lost to a victim of Nazi persecution

Include items of income you included in your federal AGI attributable to, derived from, or in any way related to assets stolen from, hidden from, or otherwise lost to a victim of Nazi persecution immediately prior to, during, and immediately after World War II, including but not limited to interest on the proceeds receivable as insurance under policies issued to a victim of Nazi persecution by European insurance companies immediately prior to and during World War II, or as a spouse or heir of such victim.

However, do not include income attributable to assets acquired with assets as described above or with the proceeds from the sale of any asset described above. Also, do not include any income if you were not the first recipient of the asset, or if you are not a victim of Nazi persecution, or a spouse or descendent of a victim.

S-12 Professional service corporation shareholders

If in a taxable year ending after 1969 and beginning before 1988, you were required to add to your federal AGI deductions made by a plan acquired through membership in a professional service corporation (PSC), **then** include the portion of those deductions that can be allocated to pension, annuity, or other income you received from the plan, and were included in your 2006 federal AGI.

S-13 Gain to be subtracted from the sale of a new business investment reported on your federal income tax return

If you reported a capital gain on your federal income tax return from the sale of a new business investment, as defined in NYS Tax Law section 612(o), that was issued before 1988 and was held at least six years, **then** include one-hundred percent (100%) of that federal gain.

S-14 Qualified emerging technology investments (QETI)

In general, you may defer the gain on the sale of QETI that are 1) held for more than 36 months, and 2) rolled over into the purchase of replacement QETI within 365 days from, and including, the date of sale. However:

- You must recognize any gain to the extent that the amount realized on the sale of the original QETI exceeds the cost of replacement QETI;
- You must add back any deferred gain in the year you sell the replacement QETI; and
- The gain deferral applies only to QETI sold on or after March 12, 1998, that was held for more than 36 months.

If you elect to defer the gain from the sale of QETI, **then** include the amount of the deferred gain. This amount may not exceed the amount of the gain included in your federal AGI.

- **If** the purchase of replacement QETI within the 365-day period occurred in the same taxable year as the sale of the original QETI, or in the following taxable year and before the date you filed your personal income tax return, **then**, take the deduction on that return.
- **If** the purchase of replacement QETI within the 365-day period occurred in the following taxable year and on or after the date you filed your personal income tax return, **then** you must file an amended return to claim the deduction (see Form IT-201-X, *Amended Resident Income Tax Return*, on page 10).
- **If** the deferred gain must be included in a subsequent year's tax return because the replacement QETI has been sold, **then** include that amount as an addition to federal AGI (see A-10 on page 84).

A QETI is an investment in the stock of a corporation, or an ownership interest in a partnership or limited liability company (LLC) that is a qualified emerging technology company, or an investment in a partnership or an LLC to the extent that such partnership or LLC invests in such companies. The taxpayer must acquire the investment as provided in IRC section 1202(C)(1)(B), or from a person who acquired it pursuant to that section. IRC

section 1202(c)(1)(B) requires the acquisition to be original issue from the company, either directly or through an underwriter, and in exchange for cash, services, or property (but not in stock).

A *qualified emerging technology company* (QETC) is a company that is located in New York State, has total annual product sales of 10 million dollars or less, and meets either of the following criteria:

- its primary products or services are classified as emerging technologies; **or**
- it has research and development activities in New York State and its ratio of research and development funds to net sales equals or exceeds the average ratio for all surveyed companies classified (as determined by the National Science Foundation in its most recent Survey of Industry Research and Development, or any comparable successor survey, as determined by the Tax Department).

S-15 Sales or dispositions of assets acquired before 1960 with greater state than federal bases

New York State income tax laws prior to 1960 and current laws regarding depletion can result in a difference in the state and federal adjusted bases of certain assets. If you realize a federally taxable gain from the sale of an asset that had a higher adjusted basis for state tax purposes, you may make an adjustment to reduce your gain for state tax purposes.

If your federal AGI included gain that was from **either**:

- property that had a higher adjusted basis for NYS income tax purposes than for federal tax purposes on December 31, 1959 (or on the last day of a fiscal year ending during 1960); **or**
- property that was held in connection with mines, oil or gas wells, and other natural deposits and that had a higher adjusted basis for NYS income tax purposes than for federal tax purposes when sold;

then include the **lesser** of the gain itself **or** the difference in the adjusted bases.

Note: If you divide gain with respect to jointly owned property between you and your spouse, then you must also divide any subtraction for different adjusted bases between you and your spouse.

S-16 Income earned before 1960 and previously reported to New York State

Include any income (including annuity income) or gain you included in your 2006 federal AGI that you (or the decedent or estate or trust from whom you acquired the income or gain) properly reported to NYS prior to 1960 (or during a fiscal year ending in 1960.)



Did you file federal Schedule(s) C-EZ, C, E, or F?

If **No**, go to the instructions for line 34.

If **Yes**, see subtraction modifications S-17 through S-32.

S-17 Trade or business interest expense on loans used to buy federally tax exempt obligations that are taxable to New York State

You may deduct interest expense you incur to buy an obligation that generates investment income that is taxable to a trade or business. **If** you included, on either line 20 or line 23, interest income from bonds or other obligations that is federally tax exempt but taxable to NYS, and the expense you incurred in buying the obligation is attributable to a trade or business you carried on, **then** include that expense.

S-18 Trade or business expenses (other than interest expense) connected with federally tax-exempt income that is taxable to New York State

You may deduct expenses you incur to acquire or maintain income that is taxable to a trade or business. **If** you included, on either line 20 or line 23, income that is federally tax exempt but taxable to NYS, **and if** the expense you incurred to either produce or collect that income or manage, conserve or protect the assets that produce that income was not deducted for federal purposes, **and if** those expenses are attributable to a trade or business you carried on, **then** include that expense.

S-19 Amortizable bond premiums on bonds that are owned by a trade or business and the interest on which is federally tax-exempt income but taxable to New York State

You may deduct expenses you incur to buy an obligation that generates investment income that is taxable to a trade or business.

If you are including, on either line 20 or line 23, interest income that is federally tax exempt but taxable to New York State, **and if** those bonds were bought for more than their face value (i.e., at a premium), **and if** you did not reduce your federal AGI by deducting the amortization of that premium attributable to 2006, **and if** those bonds were owned by a trade or business carried on by you in 2006 (as opposed to personal investments), **then** include that amortization.

S-20 Wage and salary expenses allowed as federal credits but not as federal expenses

If you took a federal Indian employment credit, a work opportunity credit, or an empowerment zone employment credit for wages and salaries paid to one or more people in certain groups, **then** include the amount of such wages you did not deduct on your federal return.

S-21 Cost depletion

If you are making addition A-12 for any percentage depletion, **then** include the cost depletion that IRC section 611 would allow on that property without any reference to either IRC section 613 or 613-a.

S-22 Special depreciation expenditures

You may carry over excess expenditures you incurred in taxable years beginning before 1987 in connection with depreciable, tangible business property located in New York State to the following tax year or years, and deduct such expenditures in computing your New York AGI for that year or years, if the expenditures exceed your New York AGI for that year before the allowance of those expenditures. Complete Form IT-211, *Special Depreciation Schedule*, to compute the amount to include. Attach Form IT-211 to your return.

S-23 Safe harbor leases

Include any amount you included in federal AGI (except for mass transit vehicles) solely because you made the safe harbor election on your federal return for agreements entered into before January 1, 1984.

S-24 Safe harbor leases

Include any amount that you could have excluded from federal AGI (except for mass transit vehicles) had you not made the safe harbor election on your federal return for agreements entered into before January 1, 1984.

S-25 New York depreciation allowed

If you claimed ACRS depreciation on your federal return for:

- property placed in service during tax years 1981 through 1984 (except IRC section 280F property); **or**
- property placed in service outside New York State for 1985 through 1993 (except IRC section 280F property) and you elect to continue using IRC section 167 depreciation (see TSB-M-99(1)I);

then include the amount of your New York depreciation. Complete and attach Form IT-399, *New York State Depreciation Schedule*, to your return.

S-26 ACRS (year of disposition adjustment)

If you disposed of property in 2006 that was depreciated for federal purposes using ACRS, **and if** your total federal ACRS deduction exceeds your New York depreciation deduction for that property, **then** complete Part 2 of Form IT-399, *New York State Depreciation Schedule*, to compute the amount to include. See addition A-16, on page 84. Attach Form IT-399 to your return.

S-27 Sport utility vehicle expense deduction recapture

If you previously claimed an IRC section 179 deduction with respect to a sport utility vehicle that weighs more than 6,000 pounds, **and** you had to recapture any amount of that deduction in computing your federal AGI for 2006, **and** if you are not an eligible farmer as defined for the farmers' school tax credit, **then** include the recapture amount. (See addition A-18 on page 84 for the definition of a sport utility vehicle.)

S-28 IRC section 168(k) property depreciation

With the exception of resurgence zone property and New York liberty zone property described in IRC section 1400L(b)(2), New York State does not follow the federal depreciation rules for IRC section 168(k) property placed in service inside or outside New York State on or after June 1, 2003. **If** you claimed a depreciation deduction for such property, **and if** no exception for resurgence zone or New York liberty zone property applies, **then** complete Part 1 of Form IT-398, *New York State Depreciation Schedule for IRC Section 168(k) Property*, to compute the amount of New York depreciation to include. Attach Form IT-398 to your return.

S-29 IRC section 168(k) property (year of disposition adjustment)

If you dispose of IRC section 168(k) property placed in service inside or outside New York State on or after June 1, 2003 (except for resurgence zone property, and New York liberty zone property described in IRC section 1400L(b)(2)), **and** your total federal depreciation deduction is more than your New York depreciation deduction for that property, **then** complete Part 2 of Form IT-398, *New York State Depreciation Schedule for IRC Section 168(k) Property*, to compute the amount of the disposition adjustment to include. Attach Form IT-398 to your return.

S-30 Royalty and interest payments made to a related member or members

For tax years beginning on or after January 1, 2003, New York requires taxpayers to add back deductions they took on their federal return for certain royalty payments for the use of intangible property, such as trademarks or patents, and interest payments they made to a related member or members. See instructions for A-21 on page 85. In such a case, the recipient of the payments must subtract the payments in computing New York AGI. If you received such a related member payment, include the amount you included in your federal taxable income. See section 612(r) of the Tax Law.



Subtractions S-31 and S-32 apply to S corporation shareholders only. For additional information, see New York State Publication 35, *New York Treatment of S Corporations and Their Shareholders*.

S-31 S corporation shareholders

If, you reported a federal gain or loss because of the disposition of stock or indebtedness of an S corporation, **and if** that S corporation was a New York C corporation for any tax year beginning after December 31, 1980 (in the case of a corporation taxable under Article 9-A, general business corporation tax), or December 31, 1996 (in the case of a corporation taxable under Article 32, banking corporation franchise tax), **then** include the reduction in basis of the stock or indebtedness that is due to the application of IRC section 1376(b) (as in effect for tax years beginning before January 1, 1983) and 1367(a)(2)(B) and (C) for each tax year that the New York election was **not** in effect.

If, with respect to stock described above, you made any New York additions to federal AGI required under addition A-25 on page 85, **then** include the total of those additions. See New York Tax Law section 612(b)(20).

S-32 S corporation shareholders — pass-through income

If you included in your federal AGI any S corporation pass-through income pursuant to IRC section 1366 and the corporation is a New York C corporation, **then** include the pass-through income.

Line 33 New York adjusted gross income

Do not leave line 33 blank.

Step 5 — Standard or itemized deduction

Standard deduction or itemized deduction (see page 92)

34 Enter your **standard deduction** (from the table below) or your **itemized deduction** (from the worksheet below). Mark an **X** in the appropriate box: Standard ... or ... Itemized

35 Subtract line 34 from line 33 (if line 34 is more than line 33, leave blank)

36 Dependent exemptions (not the same as total federal exemptions; see page 94)

37 Subtract line 36 from line 35. This is your **taxable income**.

34.									
35.									
36.					0	0	0	0	0
37.									



Be sure to use the dependent exemption worksheet to determine the amount of your dependent exemption(s).

Line 34 Standard or itemized deduction

Follow these steps to determine which deduction to use:

1. If you took the standard deduction on your federal return, or if you did not have to file a federal return, you **must** take the New York standard deduction. Use the **standard deduction table** on page 2 of Form IT-201 to find the standard deduction amount for your filing status. Enter the amount on line 34, mark an **X** in the **Standard** box, and go to line 35.
2. If you itemized deductions on your federal return, use the **itemized deduction worksheet** on page 2 of Form IT-201 and the instructions below to compute your New York itemized deduction. Compare the **line p** amount from the worksheet to your New York standard deduction amount from the standard deduction table, also on page 2. For greater tax savings, enter the **larger** of these amounts on line 34 and mark an **X** in the appropriate box, **Standard** or **Itemized**.



If you are married and filing separate returns (filing status ③), both of you must take the standard deduction unless both of you itemized deductions on your federal returns and both of you elect to itemize deductions on your New York returns.

Note: If you paid qualified college tuition expenses, your New York itemized deduction may be increased to an amount greater than your New York standard deduction as shown in the table on Form IT-201. You should complete the New York State itemized deduction worksheet on Form IT-201 to determine if your allowable New York itemized deduction is greater than your standard deduction.

New York itemized deduction overview – The starting point in computing your New York itemized deduction amount is your federal itemized deductions from federal *Schedule A*. However, differences between federal and New York State tax laws make it necessary to make certain adjustments to your federal itemized deductions in computing your New York itemized deduction.

The subtraction adjustments on line i of the NYS itemized deduction worksheet reflect the fact that New York does not allow certain federal itemized deductions such as the federal deduction for state and local income taxes. Because of limits on certain federal deductions, and the overall limit on federal itemized deductions applicable to higher income taxpayers, it may be necessary for you to complete one or more worksheets to determine the amount of the New York subtraction adjustment.

Addition adjustments on line k of the NYS itemized deduction worksheet reflect the fact that New York allows certain deductions that are not allowed for federal purposes such as expenses related to income that is exempt from federal tax but subject to New York tax.

Also, further adjustments may be required if you are subject to the New York itemized adjustment for higher income taxpayers (line m of the NYS itemized deduction worksheet), or if you elect to claim the New York itemized deduction for college tuition expenses (line o of the NYS itemized deduction worksheet).

Before you begin: Locate your federal *Schedule A*, and, if you were required to complete it, the federal itemized deduction worksheet in the instructions for Form 1040.

New York State itemized deduction worksheet instructions (page 2, Form IT-201)

Lines a through h

Enter the amounts from the designated lines of your federal *Schedule A* (Form 1040).

Line i

Subtraction adjustments A through F

To compute your New York itemized deduction, you must subtract certain amounts deducted on your federal return that cannot be deducted on your state return. Follow these steps:

1. Add the amounts of the adjustments described in items A through F below and on page 93. If this total includes any of the adjustments described in items B through F, list them on a separate piece of paper marked **Itemized deduction worksheet-subtraction adjustments**. Identify the amount of each adjustment by letter (B through F) and attach that paper to your return.

A State, local, and foreign **income** taxes from federal *Schedule A*, lines 5 and 8.

B Ordinary and necessary expenses paid or incurred in connection with income, or property held for the production of income, which is exempt from New York income tax but only to the extent included in total federal itemized deductions.

- C** Amortization of bond premium attributable to 2006 on any bond whose interest income is exempt from New York income tax, but only to the extent included in total federal itemized deductions.
- D** Interest expense on money borrowed to purchase or carry bonds or securities whose interest is exempt from New York income tax, but only to the extent included in total federal itemized deductions.
- E** If you are a shareholder of a federal S corporation that could elect but did not elect to be a New York S corporation, any S corporation deductions included in your total federal itemized deductions. If an S corporation short year is involved, you must allocate those deductions.
- F** Premiums paid for long-term care insurance to the extent deducted in determining federal taxable income (from line 5 of **Worksheet 1** below).

Worksheet 1	
Long-term care adjustment	
1. Amount of long-term care premiums included on federal Schedule A, line 1	1. _____
2. Amount from federal Schedule A, line 1	2. _____
3. Divide line 1 by line 2 and round to the fourth decimal place	3. _____
4. Amount from federal Schedule A, line 4	4. _____
5. Multiply line 4 by line 3	5. <input style="width: 50px; height: 20px;" type="text"/>

- 2. If the amount on Form IT-201, line 18, is **\$150,500 or less** (\$75,250 if married filing separately), enter the total of your subtraction adjustments on **line i**.
- 3. If the amount on Form IT-201, line 18, is **greater than \$150,500** (\$75,250 if married filing separately), you must complete **Worksheet 2** below.

Worksheet 2	
1. Enter amount from line 11 of the federal itemized deduction worksheet in the instructions for line 28 of federal Form 1040, Schedule A	1. _____
2. Enter amount from federal itemized deduction worksheet, line 3	2. _____
3. Divide line 1 by line 2 and round to the fourth decimal place	3. _____
4. Amount of subtraction adjustment A (see page 92)	4. _____
5. Amount of subtraction adjustments B (see page 92) and C (described above) that are included in total federal itemized deductions from federal Schedule A, line 28, before any federal disallowance. Also include that portion of the deductions under subtraction adjustment E that is included in lines 18, 26, and 27 of federal Schedule A (e.g., contributions)	5. _____
6. Add line 4 and line 5	6. _____
7. Multiply line 6 by line 3	7. _____
8. Subtract line 7 from line 6	8. _____
9. Enter the amount of subtraction adjustments D and E described above, excluding that portion of E included in line 5 above	9. _____
10. Enter the amount from Worksheet 1 , line 5	10. _____
11. Add lines 8, 9, and 10. Enter the total on Form IT-201, itemized deduction worksheet, line i	11. <input style="width: 50px; height: 20px;" type="text"/>

Partners — Include on **line i** the subtractions described above that apply to your share of partnership deduction items (if not included in your New York subtractions on Form IT-201). Obtain your share of partnership items from the partnership.

S corporation shareholders — If you are a shareholder of a federal S corporation that is a New York S corporation, or if you were not eligible to make the election to treat your corporation as a New York S corporation because the corporation is not subject to Article 9-A, general business corporation franchise tax, or Article 32, banking corporation franchise tax, include on **line i** subtractions B, C, D, and F described above that apply to your pro rata share of S corporation items of income, loss or deduction. If the election to be a New York S corporation terminated during the tax year, you must allocate those items. Obtain your share of S corporation items from the S corporation.

If you are a shareholder of a federal S corporation that could, but did not, elect to be a New York S corporation, include subtraction E only.

Line j

Subtract line i from line h and enter the result.

If you made no entry on line i, enter the amount from line h on line j.

Line k

Addition adjustments G, H, and I

In computing your New York itemized deduction, you may add certain amounts that you were not entitled to deduct on your federal return but that you may deduct on your New York State return.

List any of the addition adjustments below that apply to you on a separate piece of paper marked **Itemized deduction worksheet - addition adjustments**. Identify the amount of each adjustment that applies to you by item letter (G, H, and I). Add all of your addition adjustments and enter the total on **line k**. Attach that paper to your return.

- G** Interest expense on money borrowed to purchase or carry bonds or securities whose interest is subject to New York income tax, but exempt from federal income tax, if this interest expense was not deducted on your federal return or shown as a New York subtraction.
- H** Ordinary and necessary expenses paid or incurred during 2006 in connection with income, or property held for the production of income, which is subject to New York income tax but exempt from federal income tax, if these expenses were not deducted on your federal return or shown as a New York subtraction.
- I** Amortization of bond premium attributable to 2006 on any bond whose interest income is subject to New York income tax, but exempt from federal income tax, if this amortization was not deducted on your federal return or shown as a New York subtraction.

Partners — Include on **line k** the additions described above that apply to your share of partnership deduction items (if not included in your New York additions on Form IT-201). Obtain your share of partnership items from the partnership.

(continued)

S corporation shareholders — If you are a shareholder of a federal S corporation that is a New York S corporation for the tax year, or if you were not eligible to make the election to treat your corporation as a New York S corporation because the corporation is not subject to Article 9-A, general business corporation franchise tax, or Article 32, banking corporation franchise tax, include on **line k** additions **G** through **I**, described on page 93, that apply to your pro rata share of S corporation items of income, loss or deduction. If the election to be a New York S corporation terminated during the tax year, you must allocate those items. Obtain your share of S corporation items from the S corporation.

Line l

Add lines j and k and enter the total on line l.

If you made no entry on line k, enter the amount from line j on line l.

Line m

Itemized deduction adjustment

Enter the amount of your itemized deduction adjustment. If Form IT-201, line 33 is:

- \$100,000 or less, leave line m blank and go to line n;
- more than \$100,000 but not more than \$475,000, fill in **Worksheet 3** below;
- more than \$475,000 but not more than \$525,000, fill in **Worksheet 4** below; or
- more than \$525,000, enter 50% (.50) of line l on line m.

Worksheet 3

1. New York adjusted gross income from Form IT-201, line 33 1. _____
2. Filing status ① or ③ enter \$100,000 or filing status ④ enter \$150,000, or filing status ② or ⑤ enter \$200,000 2. _____
3. Subtract line 2 from line 1. (If line 2 is more than line 1, leave line m on Form IT-201 itemized deduction worksheet blank. **Do not continue with this worksheet.**) 3. _____
4. Enter the lesser of line 3 or \$50,000 4. _____
5. Divide line 4 by \$50,000 and round to the fourth decimal place 5. _____
6. Enter 25% (.25) of Form IT-201 itemized deduction worksheet, line l 6. _____
7. Multiply line 5 by line 6. 7. _____

Transfer this amount to Form IT-201 itemized deduction worksheet, line m.

Worksheet 4

1. Enter the excess of New York adjusted gross income over \$475,000 (cannot exceed \$50,000) ... 1. _____
2. Divide line 1 by \$50,000 and round to the fourth decimal place 2. _____
3. Enter 25% (.25) of Form IT-201 itemized deduction worksheet, line l 3. _____
4. Multiply line 2 by line 3 4. _____
5. Add lines 3 and 4 5. _____

Transfer this amount to Form IT-201 itemized deduction worksheet, line m.

Line n

Subtract line m from line l.

If you made no entry on line m, enter the amount from line l on line n.

Line o College tuition itemized deduction

Did you, your spouse, or your dependent(s) pay any college tuition expenses during 2006? If **No**, enter **0** and go to line p.

If **Yes**, you may be eligible to claim **either** the college tuition **itemized deduction** or the college tuition **credit**. However, **you cannot claim both**.

Complete Form IT-272, *Claim for College Tuition Credit or Itemized Deduction*, to compute your college tuition itemized deduction. Attach Form IT-272 to your return.

Line 36 Dependent exemptions



Unlike on your federal return, you may **not** take personal exemptions for yourself and for your spouse on your New York State return.

Enter the number of your dependent exemptions from the *Dependent exemption worksheet*, line e, below.

If you do not have to file a federal return, enter on lines a, b, and d of the worksheet the number of exemptions that would be allowed for federal income tax purposes.

Dependent exemption worksheet

- Check only one box:
- If you filed federal Form 1040EZ, enter **0** on line 36.
 - If you filed federal Form 1040A or 1040, complete this worksheet.
 - a. Enter the number of exemptions claimed on federal Form 1040A or 1040, line 6d a. _____
 - b. See *Line b instructions* below b. _____
 - c. Add lines a and b c. _____
 - d. Enter the total number of boxes checked on federal Form 1040A or 1040, line 6a and line 6b d. _____
 - e. Subtract line d from line c. This is the number of your dependent exemptions to enter in the box(es) on line 36 (see *Example* below) e. _____

Line b instructions – If on your federal return you were entitled to claim a dependent as an exemption but chose not to, include that dependent on line b.
Example: If you were entitled to claim a dependent on your federal return but chose not to in order to allow your dependent to claim the federal education credit on his or her federal tax return, you may still claim him or her as a dependent on your New York return.

The value of each dependent exemption is \$1,000. Therefore, if the entry on line e of the worksheet above was **2**, the entry on line 36 would look like this:

... **36.** **2,000.** **00**

Lines 37 and 38

Taxable income

Subtract line 36 from line 35. The result is your taxable income. Enter this amount on both line 37 and line 38. If line 36 is more than line 35, leave line 37 and line 38 blank.

Step 6 — Tax computation

Line 39 New York State tax

Is **line 33** (your New York AGI) \$100,000 or less?

If **Yes**, find your New York State tax using the *New York State Tax Table* on pages 46 through 53, or if **line 38** is \$65,000 or more, use the *New York State tax rate schedule* on page 55. Enter the tax due on line 39.

If **No**, see *Tax Computation — New York AGI of more than \$100,000*, on page 54.

Line 40 New York State household credit

If you marked the **Yes** box at item (C) on the front of Form IT-201, you do not qualify for this credit and should go to line 41. If you marked **No**, use the appropriate table (1, 2, or 3) below or on page 96 to determine the amount to enter on line 40.

Filing status ① only (Single) - Use *Household credit table 1* below.

Filing status ②, ④ and ⑤ - Use *Household credit table 2* below.

Filing status ③ only (Married filing separate return) - Use *Household credit table 3* on page 96.

New York State Household credit table 1
Filing status ① only (Single)

If Form IT-201, line 18 is over:	but not over	enter on Form IT-201, line 40:
\$ 5,000	\$ 5,000*	\$75
6,000	6,000	60
7,000	7,000	50
20,000	20,000	45
25,000	25,000	40
28,000	28,000	20
		No credit is allowed; do not make an entry on Form IT-201, line 40.

* This may be any amount up to \$5,000, including 0 or a negative amount.

New York State Household credit table 2
Filing status ②, ④ and ⑤

If Form IT-201, line 18 is over:	but not over	And the number of exemptions from your <i>Dependent exemption worksheet</i> , line c, page 94 (married 1040EZ filers use column 2), is:							over 7**
		1	2	3	4	5	6	7	
\$ 5,000	\$ 5,000*	\$ 90	105	120	135	150	165	180	15
6,000	6,000	75	90	105	120	135	150	165	15
7,000	7,000	65	80	95	110	125	140	155	15
20,000	20,000	60	75	90	105	120	135	150	15
22,000	22,000	60	70	80	90	100	110	120	10
25,000	25,000	50	60	70	80	90	100	110	10
28,000	28,000	40	45	50	55	60	65	70	5
32,000	32,000	20	25	30	35	40	45	50	5
		No credit is allowed; do not make an entry on Form IT-201, line 40.							

* This may be any amount up to \$5,000, including 0 or a negative amount.

** For each exemption over 7, add amount in this column to column 7 amount.

(continued)

New York State Household credit table 3

Filing status 3 only (Married filing separate return)

If Form IT-201, line 18 *** total from both returns is:

Over	but not over
\$ \$ 5,000*	
5,000	6,000
6,000	7,000
7,000	20,000
20,000	22,000
22,000	25,000
25,000	28,000
28,000	32,000
32,000	

And the number of exemptions from both *Dependent exemption worksheets*, line c, page 94, is:

	1	2	3	4	5	6	7	over 7**
Enter on Form IT-201, line 40:								
\$ 45	52.50	60	67.50	75	82.50	90	7.50	
37.50	45	52.50	60	67.50	75	82.50	7.50	
32.50	40	47.50	55	62.50	70	77.50	7.50	
30	37.50	45	52.50	60	67.50	75	7.50	
30	35	40	45	50	55	60	5	
25	30	35	40	45	50	55	5	
20	22.50	25	27.50	30	32.50	35	2.50	
10	12.50	15	17.50	20	22.50	25	2.50	

No credit is allowed; do not make an entry on Form IT-201, line 40.

* This may be any amount up to \$5,000, including 0 or a negative amount.
 ** For each exemption over 7, add amount in this column to column 7 amount.
 *** If spouse is filing Form IT-203, use the amount from the **Federal amount column**, line 18.

Line 41 Resident credit

Did you have income from sources outside New York State and pay income tax to another state, a local government of another state, the District of Columbia, or to a province of Canada? If **No**, go to line 42.

If **Yes**, complete Form IT-112-R, *New York State Resident Credit*, and, if applicable, Form IT-112-C, *New York State Resident Credit for Taxes Paid to a Province of Canada*. Enter the total amount of resident credit on line 41 and attach either form or both forms to your return.

Line 42 Other New York State nonrefundable credits

See the credit charts on pages 6 through 9 for a listing of nonrefundable credits. If you are claiming any nonrefundable credits, complete the appropriate credit forms and Form IT-201-ATT. Transfer the amount of nonrefundable credits to line 42. **You must attach the completed credit forms and Form IT-201-ATT to your return.**

Line 45 Net other New York State taxes

See the *Other credits and taxes* chart on pages 111 and 112. If you are subject to any other taxes, complete the appropriate forms and Part 2 of Form IT-201-ATT. Transfer the total amount of net other New York State taxes to line 45. **You must attach the completed forms and Form IT-201-ATT to your return.**

Line 47 New York City resident tax (NYC residents only; part-year residents, see line 50.)



If you are married and filing a joint New York State return and only one of you was a resident of New York City for all of 2006, do not enter an amount here. See the instructions for line 51 on page 98.

Is **line 38** (your New York taxable income) less than \$65,000?

If **Yes**, find your New York City resident tax using the *New York City Tax Table* on pages 56 through 63. Enter the tax on line 47.

If **No**, find your New York City resident tax using the *New York City tax rate schedule* on page 64. Enter the tax on line 47.

47	New York City resident tax on line 38 amount (see page 96)	47.										
48	New York City household credit (from table 4, 5, or 6 on page 97)	48.										
49	Subtract line 48 from line 47 (if line 48 is more than line 47, leave blank)	49.										
50	Part-year New York City resident tax (attach Form IT-360.1)	50.										
51	Other New York City taxes (from Form IT-201-ATT, line 34; attach form)	51.										
52	Add lines 49, 50, and 51	52.										
53	NY City nonrefundable credits (from Form IT-201-ATT, line 10; attach form)	53.										
54	Subtract line 53 from line 52 (if line 53 is more than line 52, leave blank)	54.										
55	Yonkers resident income tax surcharge (see page 98)	55.										
56	Yonkers nonresident earnings tax (attach Form Y-203)	56.										
57	Part-year Yonkers resident income tax surcharge (attach Form IT-360.1)	57.										
58	Add lines 54 through 57. This is the total of your New York City and Yonkers taxes/surcharges.	58.										

New York City (NYC) and Yonkers residents only:
 See instructions beginning on page 96 for figuring NYC and Yonkers taxes, credits, and tax surcharges.

Line 48 New York City household credit (NYC residents only)

If you marked the **Yes** box at item (C) on the front of Form IT-201, you do not qualify for this credit and should go to line 49. If you marked **No**, use the appropriate table (4, 5, or 6) below to determine the amount to enter on line 48.



If you are married and filing a joint New York State return and only one of you was a resident of New York City for all of 2006, do not enter an amount here. See the instructions for line 51 on page 98.

Filing status ① only (Single) - Use *Household credit table 4* below.

Filing status ②, ④ and ⑤ - Use *Household credit table 5* below.

Filing status ③ only (Married filing separate return) - Use *Household credit table 6* below.

New York City Household credit table 4
Filing status ① only (Single)

If Form IT-201, line 18 is:

Over	but not over	enter on Form IT-201, line 48:
\$ \$10,000	\$10,000*	\$ 15
10,000	12,500	10
12,500	No credit is allowed; do not make an entry on Form IT-201, line 48

* This may be any amount up to \$10,000, including 0 or a negative amount.

New York City Household credit table 5
Filing status ②, ④ and ⑤

If Form IT-201, line 18 is:

Over	but not over
\$ \$15,000	\$ 15,000*
15,000	17,500
17,500	20,000
20,000	22,500
22,500

And the number of exemptions from your *Dependent exemption worksheet*, line c, page 94 (married 1040EZ filers use column 2), is:

1	2	3	4	5	6	7	over 7**
Enter on Form IT-201 line 48:							
\$30	60	90	120	150	180	210	30
25	50	75	100	125	150	175	25
15	30	45	60	75	90	105	15
10	20	30	40	50	60	70	10

No credit is allowed; do not make an entry on Form IT-201, line 48.

* This may be any amount up to \$15,000, including 0 or a negative amount.

** For each exemption over 7, add amount in this column to column 7 amount.

New York City Household credit table 6
Filing status ③ only (Married filing separate return)

If Form IT-201, line 18 *** total from both returns is:

Over	but not over
\$ \$15,000	\$15,000*
15,000	17,500
17,500	20,000
20,000	22,500
22,500

And the number of exemptions from both *Dependent exemption worksheets*, line c, page 94 is:

1	2	3	4	5	6	7	over 7**
Enter on Form IT-201, line 48:							
\$ 15	30	45	60	75	90	105	15
12.50	25	37.50	50	62.50	75	87.50	12.50
7.50	15	22.50	30	37.50	45	52.50	7.50
5	10	15	20	25	30	35	5

No credit is allowed; do not make an entry on Form IT-201, line 48.

* This may be any amount up to \$15,000, including 0 or a negative amount.

** For each exemption over 7, add amount in this column to column 7 amount.

*** If spouse is filing Form IT-203, use the amount from the **Federal amount column**, line 18.

Line 50 Part-year New York City resident tax

If you were a New York City resident for only part of 2006, complete Form IT-360.1, *Change of City Resident Status*, and attach it to your return. For more information see Form IT-360.1-I, *Instructions for Form IT-360.1*.

Line 51 Other New York City taxes

Enter the total amount of other New York City taxes from Form IT-201-ATT, Part 3, line 34.



If you are married and filing a joint New York State return and only one of you was a resident of New York City for all of 2006, compute on a separate sheet of paper the NYC resident tax on the New York State taxable income of the city resident as if you had filed separate federal returns reduced by the NYC household credit (if applicable). The spouse that was a part-year NYC resident in 2006 should compute his or her part-year NYC resident tax on Form IT-360.1. Transfer the combined tax amounts of both spouses from your separate sheet to line 51. Be sure to write the name and social security number of the city resident and **Taxable income of New York City resident** on that paper. Attach it to your return.

If one spouse was a resident of New York City and the other a nonresident for all of 2006, compute on a separate sheet of paper the NYC resident tax on the New York State taxable income of the city resident as if you had filed separate federal returns reduced by the NYC household credit (if applicable). Transfer the amount from your separate sheet to line 51. Be sure to write the name and social security number of the city resident and **Taxable income of New York City resident** on that paper. Attach it to your return.

If you are self-employed and carry on a trade, business, or profession in New York City, you may also be required to file Form NYC-202, *New York City Unincorporated Business Tax Return*. Since New York State does not administer the NYC unincorporated business tax, do not file your Form NYC-202 with your state return.

Line 53 New York City nonrefundable credits

Can you claim either the NYC unincorporated business tax (UBT) credit or the New York City accumulation distribution credit? (See the charts on pages 6 through 9.) If **No**, go to line 54.

If **Yes**, complete *Section C* of Form IT-201-ATT and enter the amount from Form IT-201-ATT, **line 10**, on line 53.

Line 55 Yonkers resident income tax surcharge

Were you a full-year resident of Yonkers, and did you make an entry of more than **0** on line 46? If **No**, go to line 56.

If **Yes**, complete the **Yonkers Worksheet** below and enter the amount from line l.

Yonkers worksheet

- a. Amount from line 46..... a. _____
- b. Amount from new Form IT-213, *Claim for Empire State child credit*, line 16, or line 17 if an amount is entered on line 17..... b. _____
- c. Amount from Form IT-214, *Claim for Real Property Tax Credit*, line 33 c. _____
- d. Amount from Form IT-216, *Claim for Child and Dependent Care Credit*, line 14 (New York filing status ③ taxpayers, see instructions for Form IT-216) d. _____
- e. Amount from Form IT-215, *Claim for Earned Income Credit*, line 16 (New York filing status ③ taxpayers transfer the amount from Form IT-215, line 17)..... e. _____
- f. Amount from new Form IT-209, *Claim for Noncustodial Parent New York State Earned Income Credit*, line 32 or, if an amount is entered on line 42, the larger of line 32 or line 42 f. _____
- g. If you elected to claim the college tuition credit, the amount from Form IT-272, *Claim for College Tuition Credit or Itemized Deduction*, line 5 or 7, whichever applies..... g. _____
- h. Amount from Form IT-201-ATT, *Other Tax Credits and Taxes*, line 13 h. _____
- i. Add lines b through h..... i. _____
- j. Subtract line i from line a j. _____
- k. Yonkers resident tax rate (10%)..... k. .1
- l. Multiply line j by line k. Enter this amount on Form IT-201, line 55..... l.

If you are filing jointly (filing status ②) and only one spouse was a Yonkers resident for all of 2006, compute on a separate sheet of paper the Yonkers resident income tax surcharge on the New York State tax of the Yonkers resident as if you had filed separate federal returns. Enter the amount computed on line 55. Be sure to write the name and social security number of the Yonkers resident and **Yonkers resident income tax surcharge** on that paper, and attach it to your return.

Line 56 Yonkers nonresident earnings tax

If you were not a resident of Yonkers, did you earn wages or conduct a trade or business there either as an individual or as a member of a partnership? If **No**, go to line 57.

If **Yes**, complete Form Y-203, *Yonkers Nonresident Earnings Tax Return*. Enter the amount of tax on line 56 and attach Form Y-203 to your return.

Line 57 Part-year Yonkers resident income tax surcharge

If you were a resident of Yonkers for only part of 2006, complete Form IT-360.1, *Change of City Resident Status*. Enter the tax amount on line 57 and attach Form IT-360.1 to your return.

Line 59 Sales or use tax

See pages 66 through 72 for information on New York State and local sales or use tax, and how to calculate sales or use tax due.

If you do not owe any New York State or local sales or use tax, you must enter 0 on line 59. Do not leave line 59 blank. Then continue with the instructions for line 60.

Step 8 Payments and refundable credits

Payments and refundable credits (see page 100)			
63	Empire State child credit (attach new Form IT-213)	63.	
64	NY State child and dependent care credit (attach Form IT-216)	64.	
65	NY State earned income credit (EIC) (attach Form IT-215 or IT-209)	65.	
66	NY State noncustodial parent EIC (attach new Form IT-209)	66.	
67	Real property tax credit (attach Form IT-214)	67.	
68	College tuition credit (attach Form IT-272)	68.	
69	NY City school tax credit (also complete (F) on page 1; see page 101)	69.	
70	NY City earned income credit (attach Form IT-215 or IT-209)	70.	
71	Other refundable credits (from Form IT-201-ATT, line 18; attach form)	71.	
72	Total New York State tax withheld	72.	
73	Total New York City tax withheld	73.	
74	Total Yonkers tax withheld	74.	
75	Total estimated tax payments / Amount paid with Form IT-370	75.	
76	Add lines 63 through 75. This is the total of your payments.	76.	

Forms IT-2 and/or IT-1099-R must be completed and attached to your return instead of federal Forms W-2 and/or 1099-R.
 Staple them (and any other applicable forms) to the top of this page 4.
 See Step 11 on page 108 for the proper assembly of your four-page return and all attachments.

Line 63 Empire State child credit

Did you claim the **federal** child tax credit for 2006 or do you have a qualifying child (a *qualifying child* is a child who qualifies for the federal child tax credit and is at least four years of age)?

If **No**, you do not qualify for this credit. Go to line 64.
 If **Yes**, review the instructions for new Form IT-213 to see if you qualify for this credit. If you qualify, complete new Form IT-213 and transfer the amount from Form IT-213 to Form IT-201, line 63. Attach Form IT-213 to your return.

For more information, see the instructions for Form IT-213.

Line 64 New York State child and dependent care credit

Did you qualify to claim the **federal** child and dependent care credit for 2006 (whether or not you actually claimed it)?

If **No**, you do not qualify for this credit. Go to line 65.
 If **Yes**, complete Form IT-216, *Claim for Child and Dependent Care Credit*, and transfer the amount from Form IT-216 to Form IT-201, line 64. Attach Form IT-216 to your return.

For more information, see the instructions for Form IT-216.

Line 65 New York State earned income credit (NYS EIC)

Did you claim the **federal** earned income credit for 2006 on your federal income tax return?

If **No**, you do not qualify for this credit. Go to line 66.
 If **Yes**, complete Form IT-215, *Claim for Earned Income Credit*, and transfer the amount from Form IT-215 to Form IT-201, line 65. Attach Form IT-215 to your return. For more information, see the instructions for Form IT-215.

may be eligible for the noncustodial parent New York State earned income credit (noncustodial EIC). However, you cannot claim both the NYS EIC and the noncustodial EIC. Review the instructions for new Form IT-209, *Claim for Noncustodial Parent New York State Earned Income Credit*, to see if you qualify for this credit. If you qualify, complete Form IT-209 to determine which credit offers the better tax savings. If you are claiming the NYS EIC, transfer the NYS EIC from Form IT-209 to Form IT-201, line 65, and attach Form IT-209 to your return (do not attach Form IT-215). If you are claiming the noncustodial EIC, see line 66 instructions below.

If the IRS is computing your federal earned income credit, write **EIC** in the white area to the left of the money column, and leave the money column blank on line 65. You must complete Form IT-201, lines 67 through 75, but do not complete lines 76 through 80.

Complete Form IT-215, lines 1 through 9, and attach it to your return. The Tax Department will compute your New York State earned income credit and the resulting refund or amount due.

If you are due a refund, we will send you the refund along with an explanatory statement. If you owe tax, you will receive a bill that must be paid within 21 days, or by April 16, 2007 (April 17, 2007, if you file your federal return at the IRS Service Center in Andover, MA), whichever is later.

Line 66 Noncustodial parent New York State earned income credit (EIC)

Review the instructions for new Form IT-209, *Claim for Noncustodial Parent New York State Earned Income Credit*, to see if you qualify for this credit. If you qualify, complete Form IT-209. If you are claiming the noncustodial EIC, transfer the noncustodial EIC from Form IT-209 to Form IT-201, line 66. If you are claiming the NYS EIC, transfer the NYS EIC from Form IT-209 to Form IT-201, **line 65**. Attach Form IT-209 to your return (do not attach Form IT-215).

For more information, see the instructions for Form IT-209.

Step 8 IT-201



If you are a noncustodial parent and have paid child support through a support collection unit, you

(continued)

Line 67 Real property tax credit

Review the instructions for Form IT-214, *Claim for Real Property Tax Credit for Homeowners and Renters*, to see if you qualify for this credit. If you qualify, complete Form IT-214 and transfer the amount from Form IT-214 to Form IT-201, line 67. Attach Form IT-214 to your return.

Line 68 College tuition credit

Did you or your spouse or your dependent(s) pay college tuition expenses during 2006?

If **No**, you do not qualify for this credit. Go to line 69.

If **Yes**, and you **did not** claim the college tuition deduction on line o of the itemized deduction worksheet (see page 94), complete Form IT-272, *Claim for College Tuition Credit or Itemized Deduction*, and transfer the amount from Form IT-272 to Form IT-201, line 68. Attach Form IT-272 to your return.

For more information, see the instructions for Form IT-272.

Line 69 New York City school tax credit (NYC residents only)

If you marked the **Yes** box at item C on the front of Form IT-201, you do not qualify for this credit. Go to line 70.

If you marked **No** at item C and you are filing status ①, ③, ④, or ⑤, compute your credit using **Table 1** below if you were a full-year city resident or **Table 2** below if you were a part-year city resident.

If you are filing status ②, compute your credit using

Table 1 if both spouses were full-year city residents. If both spouses were part-year city residents, find your part-year NYC school tax credit using filing status ② and **Table 2**. If both spouses do not have the same city resident period, compute the credit using the spouse with the longer city resident period.

Example 1: *You were a 5-month New York City resident and your spouse was an 8-month New York City resident, and you marked filing status ②, married filing joint return. You are entitled to a credit of \$153.33 (using the 8-month period from Table 2).*

Married taxpayers (filing status ③) – If you are computing your NYC tax separately, you must determine your NYC school tax credit using filing status ②. If one spouse is a city resident and the other is a city nonresident for the entire year, and you are computing your NYC tax as married filing separately, then determine the NYC school tax credit for the city resident spouse using **Table 1** and filing status ③. The nonresident spouse is not entitled to a credit.

If one spouse is a resident and the other is a nonresident but you **elect** to compute your NYC tax as if both were residents for the entire year, determine your credit using **Table 1** and filing status ②.

If one spouse is a city resident and the other is a part-year city resident, and you are computing your NYC tax as married filing separately, you must compute your credit separately. Use the *New York City school tax credit worksheet* below and **Table 1**, filing status ③, for the resident spouse. Use the worksheet and **Table 2**, filing status ③, for the part-year resident spouse.

Example 2 — Full-year resident and a part-year resident spouse: *You and your spouse are filing a joint New York State income tax return (filing status ②). You were a resident of New York City for the entire 2006 tax year. Your spouse was a New York City resident for only 3 months during the year. Add your credit amount from Table 1 below using filing status ③ (\$115), and your spouse's credit amount from Table 2 using filing status ③ (\$28.75) for a combined credit of \$143.75.*

If one spouse was a New York City part-year resident and the other spouse was a city nonresident for the entire year, determine the part-year resident's credit using **Table 2** and filing status ③ and enter the result on line 69. The nonresident spouse may not take a credit.

**Table 1 - Full-year New York City residents:
New York City school tax credit table**

Filing status:	Your credit is:
— Single, filing status ①	\$ 115
— Married filing separate return, filing status ③	
— Head of household, filing status ④	
— Married filing joint return, filing status ②	\$ 230
— Qualifying widow(er) with dependent child filing status ⑤	

**Table 2 - Part-year New York City residents:
New York City school tax credit proration chart**

Resident period (# of months)	Filing status ①, ③ and ④ only	Filing status ② and ⑤ only
1	\$ 9.58	\$ 19.17
2	19.17	38.33
3	28.75	57.50
4	38.33	76.67
5	47.92	95.83
6	57.50	115.00
7	67.08	134.17
8	76.67	153.33
9	86.25	172.50
10	95.83	191.67
11	105.42	210.83
12	115.00	230.00

**New York City school tax credit worksheet:
filing status ② only**

1 Full-year resident spouse's credit from Table 1	1 _____
2 Part-year resident spouse's allowable credit from Table 2	2 _____
3 Add lines 1 and 2. This is your New York City school tax credit. Enter here and on Form IT-201, line 69	3 _____

Line 70 New York City earned income credit (NYC residents only)

Did you claim the **federal** earned income credit for 2006 on your federal return?

If **No**, you do not qualify to claim this credit. Go to line 71.

If **Yes**, complete **either** Form IT-215, *Claim for Earned Income Credit*, or new Form IT-209, *Claim for Noncustodial Parent New York State Earned Income Credit*. Transfer the amount from Form IT-215 or the amount from Form IT-209 to Form IT-201, line 70. Attach Form IT-215 or Form IT-209 to your return.

For more information, see the instructions for Form IT-215 or Form IT-209.

If the IRS is computing your federal earned income credit, write **EIC** in the white area to the left of the money column, and leave the money column blank on line 70. You must complete Form IT-201, lines 71 through 75, but do not complete lines 76 through 80. The Tax Department will compute your New York City earned income credit and the resulting refund or amount due.

If you are due a refund, we will send you the refund along with an explanatory statement. If you owe tax, you will receive a bill that must be paid within 21 days, or by April 16, 2007 (April 17, 2007, if you file your federal return at the IRS Service Center in Andover, MA), whichever is later.

Line 71 Other refundable credits

Enter the total amount of other refundable credits from Form IT-201-ATT, Part 1, Section D, line 18. See the credit charts on pages 6 through 9 for a listing of credits that can be refunded.

Lines 72, 73, and 74

Total New York State, New York City, and Yonkers tax withheld

If you received any federal Form(s) W-2, *Wage and Tax Statement*, you must complete Form(s) IT-2, *Summary of Federal Form W-2 Statements*. In addition, if you received foreign income but did not receive a federal Form W-2, you must complete Form IT-2. If you had New York State, New York City, or Yonkers tax withheld from annuities, pensions, retirement pay or IRA payments, you must complete Form(s) IT-1099-R, *Summary of Federal Form 1099-R Statements*.

Enter on the appropriate line your total New York State, New York City, and Yonkers tax withheld from:

- Form(s) IT-2;
- Form(s) IT-1099-R; and
- New York State lottery distributions.

Attach Form(s) IT-2 and Form(s) IT-1099-R to page 4 of your Form IT-201. If you had any NYS lottery distributions, attach federal Form W-2G as well. Do not attach federal Form W-2 or Form 1099-R to your return. Keep copies of your Form(s) IT-2, IT-1099-R, and W-2 for your records.



Check your withholding for 2007

If, after completing your 2006 tax return, you want to change the amount of tax withheld from your paycheck, complete Form IT-2104, *Employee's Withholding Allowance Certificate*, and give it to your employer.

Line 75 Total estimated tax payments and amount paid with Form IT-370

Enter the total of:

- Your 2006 estimated income tax payments for New York State, New York City, and Yonkers (include your last installment even if paid in 2007). If you marked filing status ② but made **separate** 2006 estimated income tax payments (Form IT-2105), enter your combined total estimated income tax paid;
- Any amount of overpayment from your 2005 return that you applied to your 2006 estimated income tax (if this amount was adjusted by the Tax Department, use the adjusted amount); and
- Any amount you paid with Form IT-370, *Application for Automatic Six-Month Extension of Time to File for Individuals*. If you marked filing status ② but you and your spouse filed separate Forms IT-370, enter the total amount you and your spouse paid.

Do not include any amounts you paid for the **New York City** unincorporated business tax. File Form NYC-202, *New York City Unincorporated Business Tax Return*, directly with the New York City Department of Finance.

You can check your balance and reconcile your estimated income tax account by going to www.nystax.gov and clicking on *Electronic Services*, or by writing us at:

NYS TAX DEPARTMENT
ESTIMATED TAX UNIT
W A HARRIMAN CAMPUS
ALBANY NY 12227

If you are a beneficiary of an estate or trust and are claiming your portion of any payment of estimated income taxes allocated to you by the estate or trust, include your amount on line 75 and attach a copy of the notification issued by the estate or trust to the front of your return. This notification must include the name and identifying number of the estate or trust and the amount allocated to you.

Line 80 Amount you owe

Enter on line 80 the amount of tax you owe **plus any estimated income tax penalty** you owe (see line 81 instructions).

To avoid other penalties and interest, pay any tax you owe by April 16, 2007 (April 17, 2007, if you file your federal return at the IRS Service Center in Andover, MA).

For additional information on penalties and interest, see Publication 80, *General Income Tax Information for New York State Residents*.

Line 81 Estimated tax penalty

Begin with these steps to determine if you may owe an estimated income tax penalty.

- (1) Locate the amount of your 2005 New York AGI as shown on your 2005 return;
- (2) Locate the amount of your 2005 New York income tax; then
- (3) Calculate the amount of your 2006 prepayments (the amount of withholding and estimated tax payments you have already made for 2006).

In general, you are not subject to a penalty if your 2006 prepayments equal at least 100% of your 2005 income tax. However:

- If your 2005 New York AGI was more than \$150,000 (or \$75,000 if you are married filing separately) and you are not a farmer or a fisherman, your prepayments must equal at least 110% of your 2005 income tax based on a 12 month return;
- You may owe a penalty if line 80 is \$300 or more and represents more than 10% of the income tax shown on your 2006 return; and
- You may owe a penalty if you underpaid your estimated income tax liability for any payment period.

For more information, see Form IT-2105.9, *Underpayment of Estimated Income Tax by Individuals and Fiduciaries*.

If you owe an estimated income tax penalty, enter the penalty amount on line 81. Also add the same amount to any tax due and enter the total on line 80. It is possible for you to owe an estimated income tax penalty **and also** be due a refund. In that case, subtract the estimated income tax penalty amount from the overpayment and enter the net result on line 77. **Do not include any other penalty or interest amounts on line 77.** Be sure to attach Form IT-2105.9 to your return.

Payment options**• By check or money order**

If you owe more than one dollar, include full payment with your return. Make check or money order payable to **New York State Income Tax** and write your social security number and **2006 Income Tax** on it. **Do not send cash.**

• By credit card

You can use your American Express Cards®, Discover®, Novus®, MasterCard®, or Visa® to pay the amount you owe on your 2006 New York State income tax return. You can pay your income taxes due with your return by credit card using a touch-tone phone or through the Internet. The credit card service provider **will charge** you

a convenience fee to cover the cost of this service, and you will be told the amount before you confirm the credit card payment. **Please note** that the convenience fee, terms, and conditions may vary between the credit card service providers. These are the same credit card service providers that have agreements with the IRS to process income tax payments.

You can make your payment by credit card regardless of how you file your income tax return. For returns filed before the due date, you can make credit card payments any time up to the due date. For returns filed on or after the due date, you should make your credit card payment at the same time you file your return. Credit cards cannot be used to pay any tax due on an amended return.

You can pay your income taxes due with your return using **either** of the two credit card service providers listed below.

<p>Official Payments Corp.sm Call toll free 1 800 2PAYTAXsm (1 800 272-9829), or Visit their Web site at www.officialpayments.com</p>
--

OR

<p>Link2Gov Corporation Call toll free 1 866 TAXESNY (1 866 829-3769), or Visit their Web site at www.nytaxpayment.com</p>

You can also connect to either of these Web sites by going to the Tax Department's Web site at www.nystax.gov and clicking on *Electronic Services*.

Whether paying by telephone or through the Internet, follow the simple instructions to enter personal identifying information, the credit card number and expiration date, and the amount of the payment (**line 80 of Form IT-201**). Have a copy of your completed New York State income tax return available. You will be told the amount of the convenience fee that the credit card service provider will charge you to cover the cost of this service. At this point you may elect to accept or cancel the credit card transaction.

If you accept the credit card transaction you will be given a confirmation number. **Please keep this confirmation number as proof of payment.**

For additional information go to www.nystax.gov and click on *Electronic Services*.

• By automatic bank withdrawal

You may authorize the Tax Department to make an electronic funds withdrawal from your bank account.

File now/Pay later! You must specify a future payment date up to and including April 17, 2007. If you file before April 17, money will not be withdrawn from your account before the date you specify. To avoid interest and penalties, you must authorize a withdrawal on or before the filing deadline. If you designate a weekend or a bank holiday, the payment will be withdrawn the next business day. See line 82 instructions on page 105.

Unable to pay?

To avoid interest and penalty charges, you must file and pay the amount due by April 16, 2007 (April 17, 2007, if you file your return at the IRS Service Center in Andover, MA). If you cannot pay in full, you should file your return on time, and pay as much of the tax due as possible by check, money order, or automatic bank withdrawal. Also consider alternative payment methods such as a commercial or private loan or a credit card transaction to pay any remaining balance.

You will be billed for any unpaid tax plus interest (see *Amount you owe* on page 104). Pay the bill immediately if you can; if you cannot, call the number provided on the bill to make other arrangements. If you fail to pay the amount due, New York State may file a tax warrant, seize your assets, and/or garnishee your wages to ensure payment.

Line 82 Account information

Are you requesting direct deposit of your refund to, or automatic withdrawal of your taxes from, your bank account? If **No**, go to Step 10.

If **Yes**, you must mark the appropriate box at line 82 and supply the information requested for lines 82a, b, and c.

The following requirements apply to both direct deposit and electronic funds withdrawal:

Enter your bank's 9-digit routing number on line 82a. If the first two digits are not 01 through 12, or 21 through 32, the transaction will be rejected. On the sample check below, the routing number is 090090099.

If your check states that it is payable through a bank different from the one where you have your checking account, **do not** use the routing number on that check. Instead, contact your bank for the correct routing number to enter on line 82a.

Enter your account number on line 82b. The number can be up to 17 characters (both numbers and letters). Include hyphens (-) but omit spaces and special symbols. Enter the number from left to right and leave any unused boxes blank.

On line 82c, mark an **X** in the box for the type of account, checking or savings.

- If you mark *Checking*, enter the account number shown on your checks. (On the sample check below, the account number is 1357902468. **Do not** include the check number.)
- If you mark *Savings*, you can get your savings account number from a preprinted savings account deposit slip, your passbook or other bank records, or from your bank.

If you encounter any problem with direct deposit to, or electronic withdrawal from, your account, call toll free 1 800 225-5829. Please allow six to eight weeks for processing your return.

(continued)

Note: The routing and account numbers may appear in different places on your check.

Refund — Direct deposit

Mark an **X** in the box for *Refund* on line 82.

The Tax Department will **not** notify you that your refund has been deposited. However, if the amount we deposit is different from the amount of refund you claimed, we will send you a written explanation of the adjustment within two weeks from the date your refund is deposited.

We will make every effort to comply with your request for direct deposit. However, we cannot be responsible when a bank refuses a direct deposit. Some banks, for example, do not allow a joint refund to be deposited into an individual account. You can contact your bank to confirm routing and account numbers and to make sure that it will accept your deposit. If we cannot make the direct deposit for any reason, we will send a check to the mailing address on your return.

Owe – Electronic funds withdrawal

Mark an **X** in the box for *Owe* on line 82 and enter the date you want the Tax Department to make an electronic funds withdrawal from your bank account.

The Tax Department will only use electronic funds withdrawal for the one tax payment you have authorized. Your confirmation will be your bank statement that includes a *NYS Tax Payment* line item. If we determine that the

amount you owe is different from the amount claimed on your return, we will only withdraw less than or equal to the amount you have claimed. We will send you a bill for any additional amount owed, which may include penalty and interest.

If your bank returns your electronic funds withdrawal (due to insufficient funds, incorrect bank account information, closed accounts, etc.), the Tax Department will send a notification letter to the mailing address on your return. You will need to submit a check or money order to the address on the notification, or you may elect to pay by credit card (see page 104).

We will make every effort to comply with your request for electronic funds withdrawal. However, we cannot be responsible when a bank refuses an electronic funds withdrawal. You can contact your bank to confirm routing and account numbers and to make sure that it will accept the withdrawal.

If for any reason we cannot comply with your request for electronic funds withdrawal, we will send a notice to the mailing address on your return.



If you complete the entries for electronic funds withdrawal, **do not** send a check or money order for the same amount due unless you receive a notice.



**For up-to-the-minute
information on New
York State tax matters,
including matters that
may affect your New
York State personal
income tax return, visit
our Web site at**

www.nystax.gov

Step 10 Sign and date your return

The diagram shows a portion of Form IT-201 with three sections highlighted:

- Part A:** Third-party designee section, including a question about allowing another person to discuss the return with the Tax Dept., and fields for the designee's name, phone number, and personal identification number (PIN).
- Part B:** Paid preparer's use only section, including fields for the preparer's signature, date, SSN or PTIN, employer identification number, firm's name, address, and a checkbox for self-employed.
- Part C:** Sign your return here section, including fields for the taxpayer's signature, occupation, spouse's signature and occupation (if joint return), date, and daytime phone number.

Part A Third-party designee

Do you want to authorize a friend, family member, or any other person (third-party designee) to discuss your 2006 tax return with the New York State Tax Department?

If **No**, mark an **X** in the **No** box and go to Part B.

If **Yes**, mark an **X** in the **Yes** box. Enter the designee's name, phone number, and any five numbers the designee chooses as his or her personal identification number (PIN). If you want to authorize the paid preparer who signed your return to discuss it with the Tax Department, just enter **Preparer** and the preparer's phone number in the spaces for the designee's name and phone number (you do not have to provide a PIN).

If you mark the **Yes** box, you (and your spouse, if filing a joint return) are authorizing the Tax Department to discuss with the designee any questions that arise during the processing of your return. You are also authorizing the designee to:

- give the Tax Department any information that is missing from your return;
- call the Tax Department for information about the processing of your return or the status of your refund or payment(s); and
- respond to certain Tax Department notices that you share with the designee about math errors, offsets, and return preparation. We will **not** send notices to the designee.

You are not authorizing the designee to receive your refund check, bind you to anything (including any additional tax liability), or otherwise represent you before the Tax Department. If you want the designee to perform those services for you, you must file Form POA-1, *Power of Attorney*. Copies of statutory tax notices or documents (such as a *Notice of Deficiency*) will only be sent to your designee if you file Form POA-1.

A third-party designee authorization cannot be revoked. However, the authorization will end automatically on the due date (without regard to extensions) for filing your 2007 tax return. For most taxpayers, the due date will be April 15, 2008.

Part B Paid preparer's signature

Did you pay someone to prepare your return?

If **No**, go to Part C.

If **Yes**, the paid preparer must also sign it and fill in the other blanks in the paid preparer's area of your return. A person who prepares your return and does not charge you should not fill in the paid preparer's area.

Note to paid preparers – When signing a taxpayer's New York State income tax return, you must enter the same identification number that you used on the taxpayer's federal income tax return. If you did not prepare a federal income tax return for the taxpayer, you must use your PTIN if you have one; otherwise, use your social security number. For additional information, see Publication 58, *Information for Income Tax Return Preparers*.

Part C Your signature(s)

In the spaces provided at the bottom of page 4, sign and date your **original** return and enter your occupation. If you are married and filing a joint return, also enter your spouse's occupation. Both spouses must sign a joint return; **we cannot process unsigned returns**. Keep your signature(s) within the space(s) provided.

If the return is for someone who died and there is no surviving spouse to sign it, print or type the name and address of the person signing it below the signature. For additional information about deceased taxpayers, see page 39.

Daytime phone number

This entry will enable the Tax Department to correct minor errors or omissions by calling you rather than writing or sending back your return.

Step 11 Finish your return

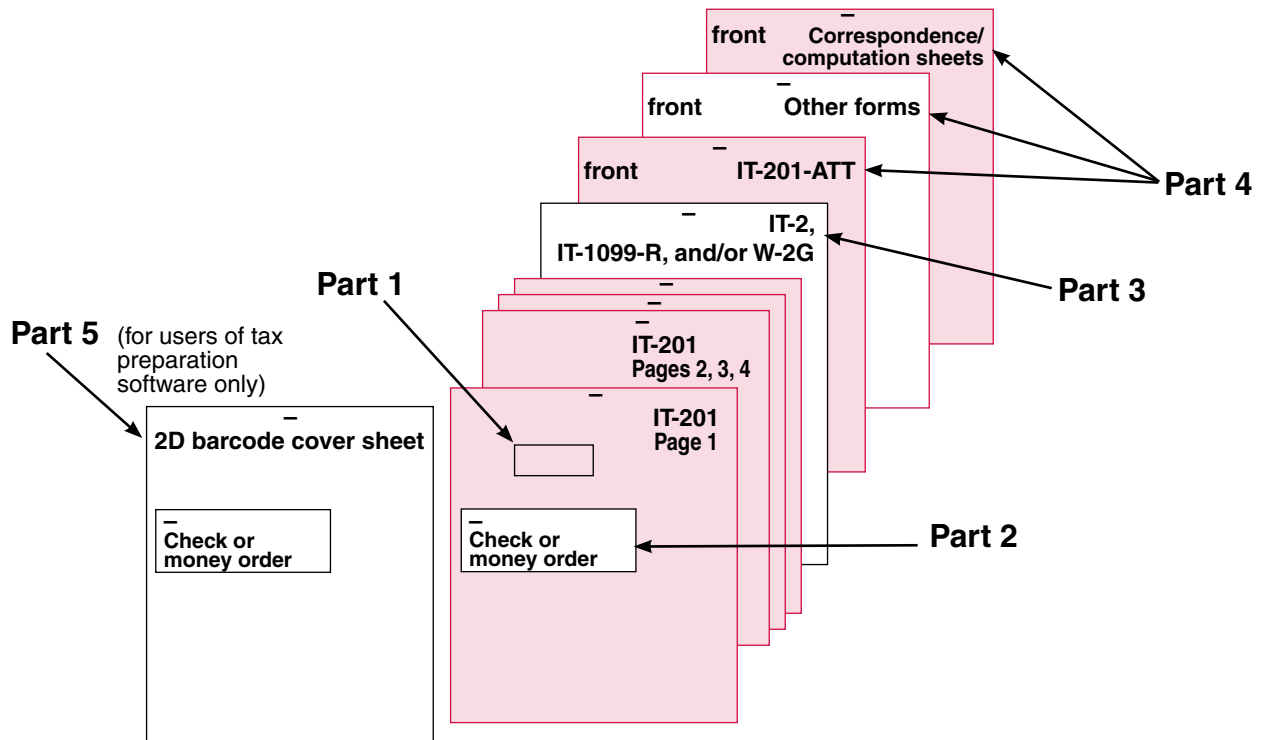

Take a moment to go over the checklist on page 113 to avoid common errors that may delay your refund. Then finish your return as shown below in Parts 1 through 7.

- Part 1** Once you have completed and reviewed the return, attach your peel-off name-and-address label, if you have one, making any necessary corrections to the information. See Step 1 if you have a question.
- Part 2** Staple payments, if any, to page 1 of your Form IT-201 where indicated.
- Part 3** Staple Form(s) IT-2 (and IT-1099-R and federal W-2G if applicable) to page 4 of your Form IT-201.
- Part 4** Staple any other forms, including Form IT-201-ATT, and any correspondence and computation sheets of paper behind your Form(s) IT-2, IT-1099-R, or W-2G face up.
- Part 5** Two-dimensional (2D) barcode cover sheet.

If your software package or preparer prints a 2D barcode cover sheet as page one of your Form IT-201, place the cover sheet face up, on the top of the front page of Form IT-201, and staple the entire return at the top of the cover sheet. Staple payments, if any, to the front of the 2D barcode cover sheet where indicated. If you need to change and reprint your return, also be sure to reprint the 2D barcode cover sheet.

Please note: Do not write, print, or photocopy anything on the back of the 2D barcode cover sheet.

- Part 6** Make a copy of your return and any other attached forms or papers for your records. You may be asked by the Tax Department to provide copies of these records after you have filed your income tax return.

- Part 7** Use the envelope provided or address an envelope to send your **original** return to the following address:

**STATE PROCESSING CENTER
PO BOX 61000
ALBANY NY 12261-0001**

Mail your return by April 16, 2007 (April 17, 2007, if you file your federal return at the IRS Service Center in Andover, MA).

If you choose, you may use a private delivery service, instead of the U.S. Postal Service, to file your return (see page 41).

Important reminder to file a complete return

You must complete all required schedules and forms that make up your return, and include all pages of those forms and schedules when you file. Attach **only** those forms and schedules that apply to your return, and be sure that you have made all required entries. Returns that are missing required pages or that have pages with missing entries are considered incomplete and cannot be processed, and may subject taxpayers to penalty and interest.

Line instructions for Form IT-201-ATT, Other Tax Credits and Taxes

Purpose of Form IT-201-ATT

You must complete Form IT-201-ATT and attach it to your Form IT-201 if:

- you are claiming other New York State, New York City, or Yonkers credits listed in the chart on pages 111 and 112 (credits that are not computed directly on Form IT-201); or
- you are subject to other New York State or New York City taxes.

Instructions

Enter your name and social security number as it is listed on your Form IT-201. If you are filing a joint return, enter both names and use the social security number of the taxpayer listed first on your Form IT-201.

The *Other credits and taxes* chart on pages 111 and 112 lists other credits you may claim and other taxes you may have to pay, along with credit **code** numbers, where applicable, and the line reference for Form IT-201-ATT.

Find the credits and taxes that apply to you. Complete the additional credit forms as indicated. Enter the money amounts on the appropriate lines and the **code** numbers, where applicable (see example below). **You must attach all applicable credit forms and tax computations to Form IT-201.**

See specific line instructions for lines 1, 9, and 22, and the special instructions for *Section B*, below and on page 110.



Where applicable, you must enter a 3-digit code number for each credit claimed and attach the credit form(s) to your Form IT-201-ATT.



Be sure to add all amounts for lines 12a through 12l and enter the total other refundable credits on line 12 (entries shown are examples only).

Line 1

If you receive an accumulation distribution as a beneficiary of a trust, you may be allowed a credit for New York State income taxes paid by the trust. Attach a copy of the computation of your New York State accumulation distribution credit provided to you by the trust and enter the amount of the credit on line 1.

Section B

This section lists credits that reduce your tax but are not refundable. If the amount of the credit exceeds your tax, you may carry the excess over to a future year (or years). **If you are claiming an original credit or a carryover of a credit, be sure to complete the appropriate credit form and attach it to your Form IT-201.**

If the amount of the credits reported in **Section B** exceeds the sum of the taxes shown on line 39 of Form IT-201 and line 21 of Form IT-201-ATT, reduced by the credits reported on lines 40 and 41 of Form IT-201, and line 2 of Form IT-201-ATT, you may have a credit carryover to 2007. If you have an excess credit and you are claiming more than one credit in **Section B**, you may apply the credits against the amount determined above in any manner you wish in order to determine the excess. However, it will be to your advantage to apply carryover credits with limited carryover periods first.

If you are claiming more than one nonrefundable carryover credit, you must complete the *Application of credit and computation of carryover* section on each individual credit form to indicate the amount of each credit you choose to apply to your 2006 tax and the amount of each credit available for carryover to 2007. **Failure to complete the *Application of credit and computation of carryover* section on the credit form(s) may cause a delay in processing your return.**

For information on credits and carryovers, see Publication 99-IND, *General Information on New York State and New York City Income Tax Credits for Individuals*, and Publication 99-B, *General Information on New York State and New York City Income Tax Credits for Businesses*.

Line 9

Compute your NYC accumulation distribution credit using the worksheet below. If you received an accumulation distribution as a beneficiary of a trust, you may be allowed a credit for NYC income taxes paid by the trust. Attach a copy of the computation of your NYC accumulation distribution credit provided to you by the trust.

NYC Accumulation distribution credit worksheet

1. Enter the amount from Form IT-201, line 49..... 1. _____
2. Enter the amount from Form IT-201-ATT, line 33..... 2. _____
3. Add lines 1 and 2..... 3. _____
4. Enter New York City accumulation distribution credit 4. _____
5. Enter the smaller of line 3 or line 4 here and on Form IT-201-ATT, line 9. This is your allowable New York City accumulation distribution credit 5.

Line 22

If the amount on Form IT-201, line 40, is **equal to or less than** the amount on Form IT-201, line 39, enter the amount from Form IT-201, line 43, on line 22.

If the amount on Form IT-201, line 40, is **more than** the amount on Form IT-201, line 39, complete the **Line 22 worksheet** below:

Line 22 worksheet

1. Enter the amount from Form IT-201, line 39..... 1. _____
2. Enter the amount from Form IT-201, line 41..... 2. _____
3. Enter the amount from Form IT-201, line 42..... 3. _____
4. Add lines 1, 2 and 3, and enter the total here and on line 22 4.



Other credits and taxes

To claim these credits or report these taxes:

See these forms and their instructions:

Report these amounts on Form IT-201-ATT line number:

Enter code:

Accumulation distribution credit New York State New York City	See instructions, pg 109 See instructions, pg 110	Line 1 Line 9	
Addback of resident credit for taxes paid to a province of Canada	IT-112-C	Lines 20a-20l	141
Alternative fuels credit Carryover portion Addback on early dispositions	IT-253 IT-253	Lines 6a-6n Lines 20a-20l	253 253
Biofuel production 	IT-243	Lines 12a-12l	303
Brownfield credits Refundable portion	IT-611 IT-612 IT-613	Lines 12a-12l Lines 12a-12l Lines 12a-12l	171 172 173
Addback	IT-611 IT-612 IT-613	Lines 20a-20l Lines 20a-20l Lines 20a-20l	171 172 173
Claim of right credit (New York State)	IT-257	Line 15	
Claim of right credit (New York City)	IT-257	Line 16	
Claim of right credit (Yonkers)	IT-257	Line 17	
Clean heating fuel 	IT-241	Lines 12a-12l	301
Conservation easement 	IT-242	Lines 12a-12l	302
Defibrillator credit	IT-250	Lines 2a-2b	250
Empire State film production credit Carryover portion Refundable portion	IT-248 IT-248	Lines 6a-6n Lines 12a-12l	248 248
EZ capital tax credit Carryover portion Addback on early dispositions	IT-602 IT-602	Lines 6a-6n Lines 20a-20l	162 162
EZ investment tax credit <i>(including EZ employment incentive credit)</i> Carryover portion Refundable portion Addback on early dispositions	IT-603 IT-603 IT-603	Lines 6a-6n Lines 12a-12l Lines 20a-20l	163 163 163
EZ wage tax credit Carryover portion Refundable portion	IT-601 IT-601	Lines 6a-6n Lines 12a-12l	161 161
Employment of persons with disabilities credit	IT-251	Lines 6a-6n	251
Farmers' school tax credit Refundable portion Addback on converted property	IT-217 IT-217	Line 11 Lines 20a-20l	217
FSI EZ investment tax credit <i>(including FSI EZ employment incentive credit)</i> Carryover portion Refundable portion Addback on early dispositions	IT-605 IT-605 IT-605	Lines 6a-6n Lines 12a-12l Lines 20a-20l	165 165 165
FSI investment tax credit <i>(including FSI employment incentive credit)</i> Carryover portion Refundable portion Addback on early dispositions	IT-252 IT-252 IT-252	Lines 6a-6n Lines 12a-12l Lines 20a-20l	252 252 252
Fuel cell electric generating equipment credit	IT-259	Lines 6a-6n	259
Green building credit	DTF-630	Lines 6a-6n	630

(continued)



Other credits and taxes *(continued)*

To claim these credits or report these taxes:

See these forms and their instructions:

Report these amounts on Form IT-201-ATT line number:

Enter code:

Handicapped-accessible taxicabs and livery service vehicles credit 	IT-239	Lines 6a-6n	299
Historic barn rehabilitation credit	See <i>Investment Credit</i> below		
Home heating system 	IT-240	Lines 12a-12l	300
IMB credit for energy taxes	DTF-623	Lines 12a-12l	623
Investment credit <i>(including employment incentive credit and historic barn rehabilitation credit)</i>			
Carryover portion	IT-212	Line 4	
Refundable portion	IT-212	Lines 12a-12l	212
Addback on early dispositions	IT-212	Lines 20a-20l	212
Long-term care insurance credit	IT-249	Line 3	
Low-income housing credit			
Carryover portion	DTF-624	Lines 6a-6n	624
Addback	DTF-626	Lines 20a-20l	626
Lump-sum distributions (credit)			
Resident credit	IT-112.1	Line 27	
Lump-sum distributions (taxes)			
New York State separate tax	IT-230	Line 26	
New York State capital gain portion	IT-230	Line 19	
New York City separate tax	IT-230	Line 32	
New York City capital gain portion	IT-230	Line 33	
Minimum income tax			
New York State minimum income tax	IT-220	Line 29	
New York City minimum income tax	IT-220	Line 31	
Nursing home assessment credit	IT-258	Lines 12a-12l	258
QETC capital tax credit			
Carryover portion	DTF-622	Lines 6a-6n	622
Addback on early dispositions	DTF-622	Lines 20a-20l	622
QETC employment credit	DTF-621	Lines 12a-12l	621
QETC facilities, operations, and training credit	DTF-619	Lines 12a-12l	619
QEZE credit for real property taxes			
Refundable portion	IT-606	Lines 12a-12l	166
Addback	IT-606	Lines 20a-20l	166
QEZE tax reduction credit	IT-604	Lines 2a-2b	164
Residential fuel oil storage tank credit carryover	See below*	Lines 6a-6n	054
Security officer training credit 	IT-631	Lines 12a-12l	631
Solar energy system equipment credit	IT-255	Line 5	
Solar and wind energy credit carryover	See below*	Lines 6a-6n	052
Special additional mortgage recording tax credit			
Carryover portion	IT-256	Lines 6a-6n	256
Refundable portion	IT-256	Lines 12a-12l	256
Unincorporated business tax credit (New York City)	IT-219	Line 8	
ZEA wage tax credit	IT-601.1	Lines 6a-6n	160

* Taxpayers carrying over any unused credit(s) from 2005 to 2006 must attach a schedule(s) showing how the carryover(s) was computed. Be sure to enter the applicable code shown above for the credit(s) carryover(s) you are claiming.

Checklist for Form IT-201

Did you . . .

- 1 use a 2006 form?
- 2 attach your peel-off label or write in your name(s) and address? (Enter your permanent home address if different from your mailing address.)
- 3 enter your social security number(s)?
- 4 enter your county, school district name, and school district code if you did not have a label or your label was incorrect?
- 5 mark your filing status?
- 6 complete items (B) through (G) (including (D) if you do **not** need a NYS tax packet mailed to you next year)?
- 7 double-check your math?

and...

- 8 enter any public employee 414(h) retirement contributions?
- 9 include any New York City IRC 125 flexible benefits program amounts?
- 10 mark an X in the *Standard* or *Itemized* deduction box on line 34?
- 11 enter your dependent exemption(s)?

(continued)

Checklist for Form IT-201 (continued)

Did you . . .

- 12 use the correct New York State or New York City tax table?
- 13 take all the tax credits for which you qualify, and attach all appropriate credit forms?
- 14 complete and attach Form IT-201-ATT if you claimed other New York State, New York City, or Yonkers credits, or if you are subject to other New York State or New York City taxes?
- 15 report any sales or use tax you owe? (Do not leave line 59 blank.)

and...

- 16 enter your refund or amount you owe?
- 17 enter the amount, if any, you want applied to your 2007 estimated tax?
- 18 make your check payable to **New York State Income Tax**, and write your social security number and **2006 Income Tax** on it?
or
use either of the two providers listed on page 104, if paying by credit card?
- 19 mark Yes if you designated another person to discuss your return with the Tax Department?
- 20 sign your return? (Both husband and wife must sign a joint return.)
- 21 staple your Form(s) IT-2 here (and attach Forms IT-1099-R and W-2G, if applicable, Form IT-280 if you are a nonobligated spouse, and any other applicable forms)?



Forms and Publications Ordering Information (Selected forms and publications)

IT-86

The New York State Department of Taxation and Finance offers a variety of quick and easy ways to get selected forms and publications.



Personal computer To download forms and publications, access the department's Internet Web site at www.nystax.gov.



Automated phone ordering You may order two forms per telephone call. See the back of this form for a list of available forms.

Automated forms telephone ordering system

To use our automated forms telephone system (24 hours a day, 7 days a week), call 1 877 218-7181. Your address must **not** have changed since you filed your last income tax return, and you must be calling from a touch-tone telephone. Please have the following information available:

1. You will be asked to enter and verify your social security number.

2. You will be asked to enter and verify your five-digit ZIP code.

3. The address on file will be read to you. If correct, you will be asked to enter only the code number(s) that correspond(s) to the form(s) you need (see the back).

You can also get forms and publications by calling toll free 1 800 462-8100 (8:00 A.M. to 5:00 P.M., eastern time Monday through Friday). From areas outside the U.S. and outside Canada, call (518) 485-6800.

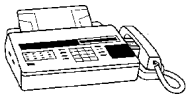

Fax-on-demand If you have a fax machine and a touch-tone phone, you can get most forms and publications from our Fax-on-demand system 24 hours a day, 7 days a week, by calling 1 800 748-3676.



Walk-in You can pick up some of the most requested forms at many post offices, libraries, and Tax Department offices. At some offices and libraries, forms are available for you to photocopy.

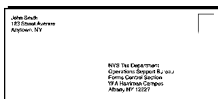

Mail You can order forms and publications by mail. See the back of this form for a list of available forms.

- Remove this ordering information form from your income tax packet (or print it from the Web site)
- Mark an **X** in the box next to the form or publications you need (we will send you two copies of each form, one copy of each instruction, and one copy of each publication you request)
- Enter your name and address in the space provided on the back
- Enclose this form (IT-86) in your own envelope and send it to:

**NYS TAX DEPARTMENT
OSB — FORMS CONTROL SECTION
W A HARRIMAN CAMPUS
ALBANY NY 12227**



CD-ROM You can purchase Publication 352-CD, a CD-ROM for personal computers that contains over 600 income, corporation, and withholding tax forms, instructions, and some publications. To order Publication 352-CD write to: NYS Tax Department, OSB — Forms Control Section, W A Harriman Campus, Albany NY 12227. Include a check or money order payable to **New York State Tax Forms**. The cost is \$5 for each CD-ROM you are ordering. Publication 352-CD is expected to be available by early February.

Forms and publications: automated telephone orders or mail orders

Use the listing below if you are using our automated forms ordering system or ordering forms by mail (*see instructions on the front page*).

(Code)	Form/publication number and title	(Code)	Form/publication number and title
(264)	<input type="checkbox"/> IT-2 Summary of Federal Form W-2 Statements	(150)	<input type="checkbox"/> IT-249 Claim for Long-Term Care Insurance Credit
(265)	<input type="checkbox"/> IT-1099-R ... Summary of Federal Form 1099-R Statements	(144)	<input type="checkbox"/> IT-251 Credit for Employment of Persons with Disabilities
(263)	<input type="checkbox"/> IT-150 Resident Income Tax Return (short form)	(146)	<input type="checkbox"/> IT-255 Claim for Solar Energy System Equipment Credit
(102)	<input type="checkbox"/> IT-201 Resident Income Tax Return (long form)	(268)	<input type="checkbox"/> IT-258 Claim for Nursing Home Assessment Credit
(103)	<input type="checkbox"/> IT-201-ATT... Other Tax Credits and Taxes (Attachment to Form IT-201)	(269)	<input type="checkbox"/> IT-259 Claim for Fuel Cell Electric Generating Equipment Credit
(140)	<input type="checkbox"/> IT-201-X Amended Resident Income Tax Return	(261)	<input type="checkbox"/> IT-272 Claim for College Tuition Credit or Itemized Deduction
(104)	<input type="checkbox"/> IT-203 Nonresident and Part-Year Resident Income Tax Return	(119)	<input type="checkbox"/> IT-280 Nonobligated Spouse Allocation
(105)	<input type="checkbox"/> IT-203-ATT... Other Tax Credits and Taxes (Attachment to Form IT-203)	(258)	<input type="checkbox"/> IT-285 Request for Innocent Spouse Relief
(259)	<input type="checkbox"/> IT-203-B..... Nonresident and Part-Year Resident Income Allocation and College Tuition Itemized Deduction Worksheet	(120)	<input type="checkbox"/> IT-360.1 Change of City Resident Status (New York City or Yonkers)
(134)	<input type="checkbox"/> IT-203-C Nonresident or Part-Year Resident Spouse's Certification	(121)	<input type="checkbox"/> IT-370 Application for Automatic Six-Month Extension of Time to File for Individuals
(141)	<input type="checkbox"/> IT-203-X Amended Nonresident and Part-Year Resident Income Tax Return	(122)	<input type="checkbox"/> IT-370-PF..... Application for Automatic Six-Month Extension of Time to File for Partnerships and Fiduciaries
(107)	<input type="checkbox"/> Y-203 Yonkers Nonresident Earnings Tax Return	(123)	<input type="checkbox"/> IT-398 New York State Depreciation Schedule for IRC Section 168(k) Property
(110)	<input type="checkbox"/> IT-205 Fiduciary Income Tax Return	(124)	<input type="checkbox"/> IT-2104 Employee's Withholding Allowance Certificate (for 2007)
(111)	<input type="checkbox"/> IT-205-A..... Fiduciary Allocation	(125)	<input type="checkbox"/> IT-2105-MN .. Estimated Income Tax Payment Voucher for Individuals
(135)	<input type="checkbox"/> IT-205-T Allocation of Estimated Tax Payments to Beneficiaries	(267)	<input type="checkbox"/> IT-2106-MN .. Estimated Income Tax Payment Voucher for Fiduciaries
(113)	<input type="checkbox"/> Y-206 Yonkers Nonresident Fiduciary Earnings Tax Return	(200)	<input type="checkbox"/> IT-2105.9..... Underpayment of Estimated Income Tax by Individuals and Fiduciaries
(108)	<input type="checkbox"/> IT-113-X Claim for Credit or Refund of Personal Income Tax	(266)	<input type="checkbox"/> IT-112-C New York State Resident Credit for Taxes Paid to a Province of Canada
(272)	<input type="checkbox"/> IT-209 Claim for Noncustodial Parent New York State Earned Income Credit	(126)	<input type="checkbox"/> IT-112-R New York State Resident Credit
(114)	<input type="checkbox"/> IT-212 Investment Credit	(127)	<input type="checkbox"/> IT-112.1 New York State Resident Credit Against Separate Tax on Lump-Sum Distributions
(270)	<input type="checkbox"/> IT-213 Claim for Empire State Child Credit	(128)	<input type="checkbox"/> Pub. 88 General Tax Information for New York State Nonresidents and Part-Year Residents
(115)	<input type="checkbox"/> IT-214 Claim for Real Property Tax Credit for Homeowners and Renters	(129)	<input type="checkbox"/> Pub. 22 FAQs: New York State's Real Property Tax Credit for Homeowners and Renters
(136)	<input type="checkbox"/> IT-215 Claim for Earned Income Credit	(130)	<input type="checkbox"/> Pub. 361 New York State Income Tax Information for Military Personnel and Veterans
(138)	<input type="checkbox"/> IT-216 Claim for Child and Dependent Care Credit	(131)	<input type="checkbox"/> Pub. 99 General Information on New York State and New York City Income Tax Credits
(139)	<input type="checkbox"/> IT-217 Claim for Farmers' School Tax Credit	(133)	<input type="checkbox"/> Pub. 131 Your Rights and Obligations Under the Tax Law
(149)	<input type="checkbox"/> NYC-210 Claim for New York City School Tax Credit	(148)	<input type="checkbox"/> Pub. 55 Designated Private Delivery Services
(143)	<input type="checkbox"/> IT-219 Credit for New York City Unincorporated Business Tax		<input type="checkbox"/> _____
(116)	<input type="checkbox"/> IT-220 Minimum Income Tax		<input type="checkbox"/> _____
(117)	<input type="checkbox"/> IT-221 Disability Income Exclusion		
(118)	<input type="checkbox"/> IT-230 Separate Tax on Lump-Sum Distributions		
(271)	<input type="checkbox"/> IT-240 Claim for Home Heating System Credit		

If you are ordering forms and/or publications by mail, enter your name and address in the space below.

Print or type	First name and initial	Last name
	Home address (<i>number and street or rural route</i>)	Apartment number
	City, village, or post office	State ZIP code

Need help? Go to www.nystax.gov or see the back cover.



**For up-to-the-minute
information on New
York State tax matters,
including matters that
may affect your New
York State personal
income tax return, visit
our Web site at**

www.nystax.gov

Index

- Accumulation distribution credit** 6, 110
- ACRS deduction** 84, 90
- Additions** 18, 19, 81-85, 93-94
- Alternative fuels credit** 3, 6, 8, 111
- Amended return** 10, 40
- Armed forces** 15, 16, 22, 38, 40, 66, 77, 79, 88
- Biofuel production credit** 3, 8, 111
- Brownfield tax credits** 3, 8, 111
- Checklists** 36-37, 113-114
- Child and dependent care credit** 6, 29, 100
- Child's investment income** 5
- Claim of right credit** 6, 111
- Clean heating fuel credit** 3, 8, 111
- Collection of debts from your refund** 31, 103
- College savings program** 18, 19, 21, 82, 87
- College tuition credit/itemized deduction** 6, 30, 94, 101
- Combat zone relief** 16, 79
- Common words and phrases** 4
- Conservation easement credit** 3, 6, 8, 111
- Credits against tax** 6-9, 29, 30, 95-98, 100-102, 109-112
- Credit card payment** 32, 104
- Deceased taxpayers** 15, 39, 77
- Deductions**
 - New York itemized 92-94
 - standard 24, 92
- Deferred compensation** 18, 20, 82, 86
- Defibrillator credit** 6, 8, 111
- Dependents, exemptions for** 24, 94
- Depreciation** 10, 84, 85, 90, 91
- Direct deposit** 33, 105, 106
- Disability income exclusion** 10, 21, 22, 87, 88
- Disclaiming of spouse's debt** 31, 103
- Earned income credit (EIC)**
 - New York City 6, 30, 102
 - New York State 6, 29, 100
 - Noncustodial parent 3, 29, 30, 100
- E-file** 2, 16, 78
- Electronic services** 11
- Empire State child credit** 3, 6, 29, 100
- Empire State film production credit** 3, 8, 111
- Empire zone (EZ) credits** 8, 111
- Estates and trusts (beneficiaries)** 39, 81
- Estimated income tax** 10, 30, 31, 102, 103
- Estimated income tax penalty** 32, 104
- Extension of time to file** *back cover*
- Farmers' school tax credit** 3, 8, 84, 111
- Federal (IRS)**
 - changes – see *Amended return*
 - income and adjustments 17, 80
 - pensions 20, 86
 - filing status 16, 78
 - filing in your return 4
 - financial services industry (FSI) credits 8, 111
 - finish your return 35, 108
 - fuel cell electric generating equipment credit 6, 8, 111
- Green building credit** 6, 8, 111
- Handicapped-accessible taxicabs and livery service vehicles credit** 3, 8, 112
- Historic barn rehabilitation credit** 6, 8, 112
- Home heating system credit** 3, 6, 112
- Homeowners** 7, 30, 101
- Household credit**
 - New York City 6, 26-27, 97
 - New York State 6, 25-26, 95-96
- Industrial or manufacturing business (IMB) credit** 9, 112
- Innocent spouse relief** 40
- Interest and penalties** 11, 32, 33, 103-105
- Internal Revenue Code (IRC)**
 - 125 amount 19, 20, 83, 87
- Internal Revenue Code (IRC) section 168(k) property** 10, 85, 91
- Investment credit** 9, 112
- Line instructions**
 - Form IT-150 15-35
 - Form IT-201 77-108
 - Form IT-201-ATT 109-112
- Living quarters in New York City** 78
- Long-term care insurance credit** 7, 9, 93, 112
- Long-term residential care deduction** 22, 88
- Lottery distributions – see *Wage and tax statements***
- Low-income housing credit** 9, 112
- Lump-sum distributions** 10, 112
- MABSTOA pensions** 18-20, 82, 83, 86
- Military personnel** 15, 16, 22, 38, 40, 66, 77, 79, 88
- Minimum income tax** 10, 112
- Name, address, and social security number** 15, 77
- Nazi persecution victims** 23, 88
- New York City taxes** 3, 26, 96, 98
- Noncustodial parent EIC** 3, 29, 30, 100
- Nonobligated spouse** 31, 40, 103
- Nonrefundable credits**
 - New York City 6, 9, 98, 111, 112
 - New York State 6, 7, 96, 111, 112
- Nonresident** 5, 10, 27, 38, 39
- Nursing home assessment credit** 112
- Optional retirement program** 18, 19, 82, 86
- Organized militia** 3, 22, 88
- Other forms you may have to file** 9-10
- Other taxes** 9-10, 96, 109-112
- Paid preparers** 34, 40, 107
- Partnerships and limited liability companies** 40, 81, 93
- Part-year resident** 38, 39
- Payment options** 32, 104
- Peel-off label** 15, 35, 77, 108
- Pensions and annuities** 20, 21, 86, 87
- Permanent home address** 15, 77
- Privacy notification** 41
- Private delivery services** 41
- Public employee 414(h) retirement contributions** 18, 82
- QETC (qualified emerging technology company)** 9, 89, 112
- QETI (qualified emerging technology investments)** 84, 89
- QEZE (qualified empire zone enterprise)** 9, 112
- Real property tax credit** 7, 30, 101
- Refundable credits** 6-9, 29, 30, 100-102, 111, 112
- Refunds** 2, 11, 31-33, 41, 103-106
 - collection of debts 31, 103
 - direct deposit 33, 106
 - disclaiming of spouse's debt 31, 40, 103
- Renters** 7, 30, 101
- Resident** 38, 39
- Resident credit** 7, 96, 98, 111, 112
- Rounding dollars and cents** 4
- Sales or use tax** 27, 66-72, 98
- School district names and codes** 15, 42-45, 77
- School tax credit** 7, 30, 79, 101
- S corporations** 81-82, 84, 85, 91, 93, 94
- Security officer training credit** 3, 9, 112
- Signatures** 34, 107
- Social security number** 15, 34, 77, 107, 109
- Solar energy system equipment** 3, 7, 112
- Solar and wind energy systems** 7, 83, 112
- Sport utility vehicles** 84, 91
- Standard deduction** 3, 24, 92
- Statute of limitations** 41
- Subtractions** 20-23, 81, 86-93
- Tax due (amount you owe)** 32, 33, 104-106
- Tax records** 40
- Tax tables and rate schedules**
 - New York City 56-64
 - New York State 46-55
- Tax withheld** 9, 30, 102
- Third-party designee** 34, 107
- 2D barcode page** 35, 108
- Unincorporated business tax (UBT) credit** 9, 98, 112
- U.S. citizens abroad** *back cover*
- Use tax (or sales tax)** 27, 66-72, 98
- Voluntary contributions** 28, 99
- Wage and tax statements** 9, 30, 102
- Web site address** 11, 14
- What's new for 2006?** 3
- When to file** *back cover*
- Where to file** 35, 108
- Which form to file** 5
- Who must file** 5
- Withholding allowance** 30, 102
- Yonkers taxes** 10, 27, 38, 98, 109
- Zone equivalent area (ZEA) tax credit** 9, 112

When to file/Important dates



April 16, 2007

Date by which you must file your 2006 New York State income tax return and pay any amounts you owe without interest or penalty (April 17, 2007, if you file your federal return at the IRS Service Center in Andover, MA). If you cannot file by this date, you can get an automatic 6-month (October 15, 2007) extension of time to file by completing and returning Form IT-370, *Application for Automatic Six-Month Extension of Time to File for Individuals* (see *Need help?* below).

June 15, 2007

Date by which you must file your 2006 New York State income tax return if you qualify to file your federal income tax return on June 15, 2007, because:

- (1) you are a U.S. citizen or resident and live outside the U.S. and your main place of business or post of duty is outside the U.S. and Puerto Rico, or
- (2) you are in the military service outside the U.S. and Puerto Rico when your 2006 return is due. The time to pay your New York State, New York City and Yonkers income tax, and any New York State or local sales or use tax is similarly automatically extended. You must attach to your New York State return a statement showing that you qualify for the federal automatic two-month extension.

Military Personnel — For more information on extensions of time to file, see Publication 361, *New York State Income Tax Information for Military Personnel and Veterans*.

October 15, 2007

Date by which you must file your 2006 income tax return to avoid penalties and interest computed from the original due date if you filed Form IT-370, *Application for Automatic Six-Month Extension of Time to File for Individuals*, and paid any tax you owed with the form.

April 16, 2007

June 15, 2007

September 17, 2007

January 15, 2008

Due dates for 2007 estimated tax payments. Generally, you must pay estimated income tax if you expect to owe at least \$300 of New York State or New York City or Yonkers income tax after deducting tax withheld and credits you are entitled to claim.

Need help?



Internet access: www.nystax.gov

Access our Answer Center for answers to frequently asked questions; check your refund status; check your estimated tax account; download forms and publications; get tax updates and other information.



Fax-on-demand forms: Forms are

available 24 hours a day,
7 days a week.

1 800 748-3676



Telephone assistance is available from 8:00 A.M. to 5:00 P.M. (eastern time), Monday through Friday.

Refund status: 1 800 443-3200

(Automated service for refund status is available 24 hours a day, 7 days a week.)

To order forms and publications: 1 800 462-8100

Personal Income Tax Information Center: 1 800 225-5829

From areas outside the U.S. and outside Canada: (518) 485-6800



Hotline for the hearing and speech impaired: If you have access to a telecommunications device for the deaf (TDD), contact us at 1 800 634-2110. If you do not own a TDD, check with independent living centers or community action programs to find out where machines are available for public use.



Persons with disabilities: In compliance with the Americans with Disabilities Act, we will ensure that our lobbies, offices, meeting rooms, and other facilities are accessible to persons with disabilities. If you have questions about special accommodations for persons with disabilities, please call 1 800 225-5829.



Think e-file... It's easy, fast, and safe.
Log on to www.nystax.gov/elf for more information.

